

Preliminary Plan Submission

The Village at Curtis Corner

Curtis Corner Road
South Kingstown, Rhode Island
Assessor's Plat 40-4 Lot 55



Sheet Index

- 1 Cover Sheet
- 2 Aerial Half Mile Radius
- 3 General Notes and Legend
- 4 Existing Conditions Plan
- 5 Soil Erosion & Sediment Control Plan
- 6 Site Layout Plan
- 7 Grading Plan - 1
- 8 Grading Plan - 2
- 9 Grading Plan - 3
- 10 Plan and Profile
- 11 BMP A Details
- 12 BMP B Details
- 13 Detail Sheet- 1
- 14 Detail Sheet - 2
- 15 Detail Sheet - 3
- 16 Perimeter & Open Space Plan
- 17 Record Plan

SESC / O&M

The Soil Erosion and Sediment Control Plan (SESC) and Stormwater Operation and Maintenance Plan (O&M) are required documents with this plan set and must be maintained by the contractor and owner on site.

DiPrete Engineering

Two Stafford Court Cranston, RI 02920
tel 401-943-1000 fax 401-464-6006 www.diprete-eng.com

Boston • Providence • Newport

KEVIN DEMERS
REGISTERED
PROFESSIONAL ENGINEER
CIVIL



LOCATION MAP N.T.S.

This regulatory submission set shall not be used for construction purposes unless stamped, issued for construction and signed by a DiPrete Engineering representative.

The contractor is responsible for all of the means, methods, safety precautions and requirements, and OSHA conformance in the implementation of this plan and design.

NO.	DATE	DESCRIPTION	BY	DESIGN BY
1	10/28/2020	Preliminary Revisions	CHD	Design By: C.H.D.
2	01/26/2021	Preliminary Revisions	CHD	
3	07/29/2020	Preliminary Revisions	CHD	
4	07/29/2020	Preliminary Revisions	CHD	

Cover Sheet
The Village at Curtis Corner

Assessor's Plat 40-4 Lot 55
South Kingstown, Rhode Island
Applicant/Owner
5A Builders, LLC
220 Knowlesway Extension
Narragansett, RI 02882

z:\beman\projects\0265-053\curtis corner road 109\autocad drawings\0265-053\cwr.dwg Plotted: 7/30/2020

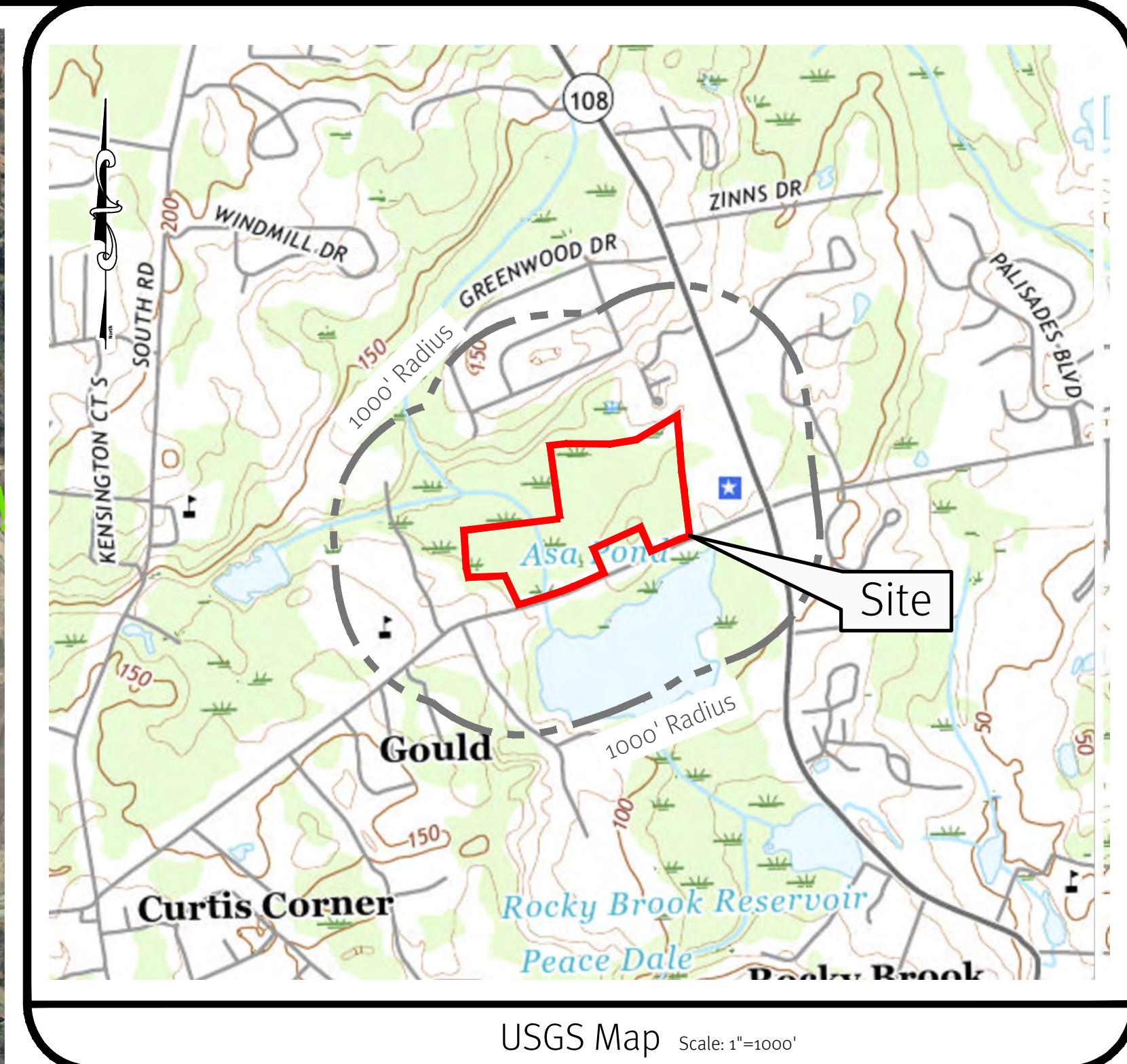
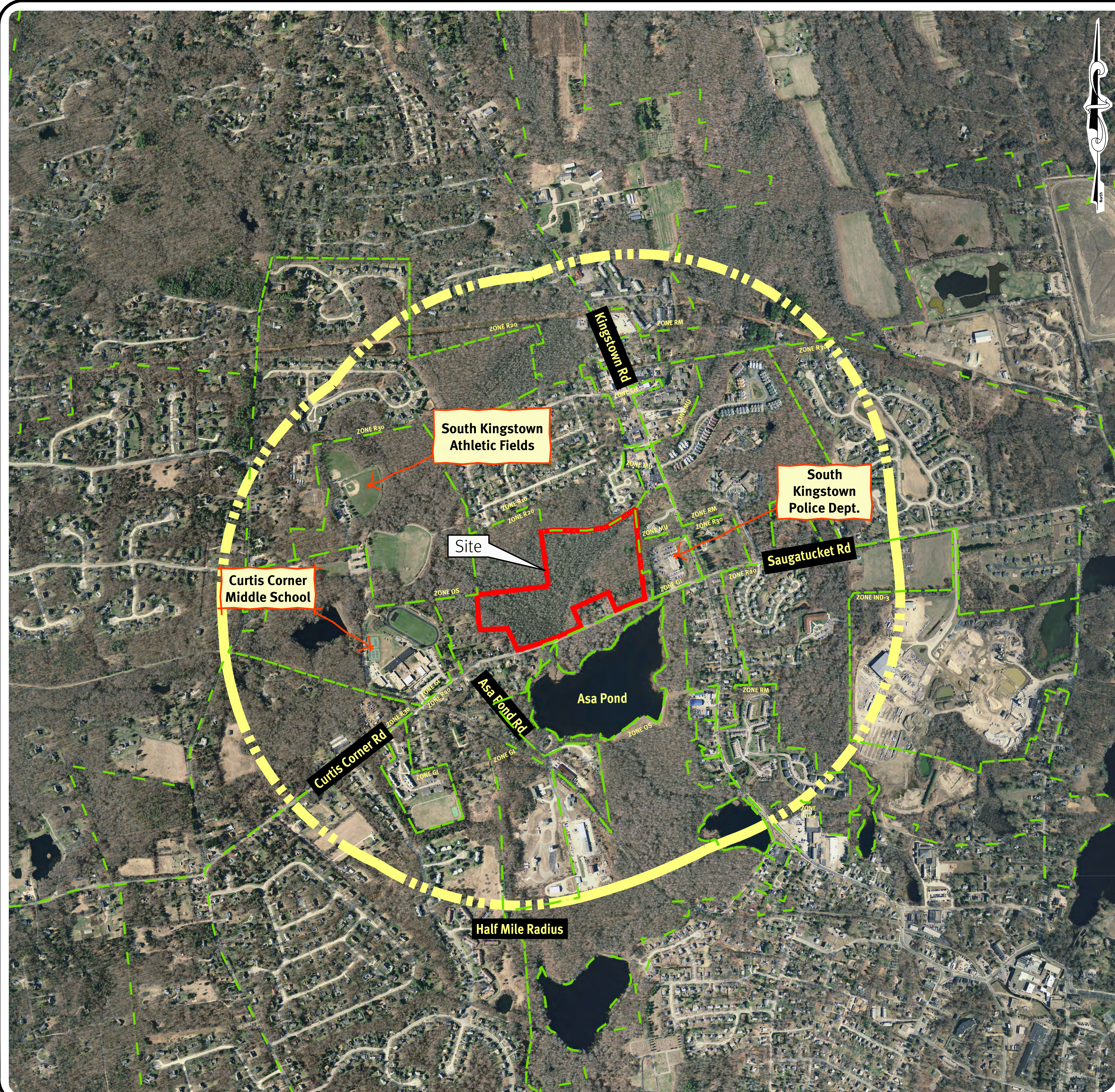
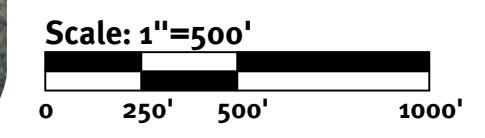
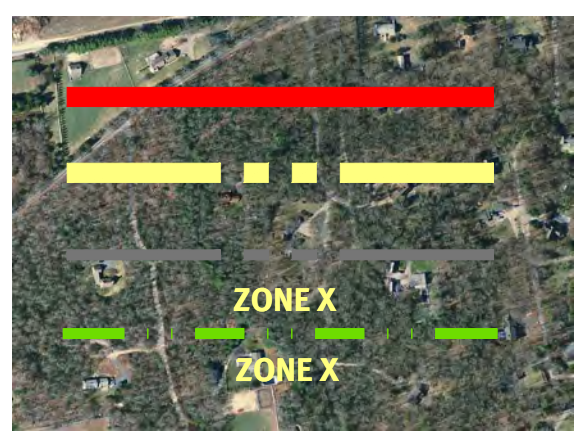

Photo obtained from the RI-GIS.

Legend:

- PROPERTY LINE
- HALF MILE RADIUS LINE
- 1000' USGS RADIUS LINE
- ZONING BOUNDARY



DiPrete Engineering
 Two Stafford Court Cranston, RI 02920
 tel 401-943-1000 fax 401-664-6006 www.diprete-eng.com

Boston • Providence • Newport

KEVIN DEMERS
 REGISTERED PROFESSIONAL ENGINEER CIVIL

This regulatory submission set shall not be used for construction purposes unless stamped, issued for construction and signed by a DiPrete Engineering representative.

The contractor is responsible for all of the means, methods, safety precautions and requirements, and OSHA compliance in the implementation of this plan and design.

0	7/30/2020	Drawn By: I.M.F.	Design By: C.D.
1			
2			
3			
4			
5			
6			
7			
8			
9			
10			
11			
12			
13			
14			
15			
16			
17			
18			
19			
20			
21			
22			
23			
24			
25			
26			
27			
28			
29			
30			
31			
32			
33			
34			
35			
36			
37			
38			
39			
40			
41			
42			
43			
44			
45			
46			
47			
48			
49			
50			
51			
52			
53			
54			
55			
56			
57			
58			
59			
60			
61			
62			
63			
64			
65			
66			
67			
68			
69			
70			
71			
72			
73			
74			
75			
76			
77			
78			
79			
80			
81			
82			
83			
84			
85			
86			
87			
88			
89			
90			
91			
92			
93			
94			
95			
96			
97			
98			
99			
100			

Aerial Half Mile Radius
The Village at Curtis Corner
 Accession Plat 40-4-000-053
 South Kingstown, Rhode Island
 Applicant Owner
SA Builders, LLC
 220 Knowlesway Extension
 Narragansett, RI 02882

DE Job No: 0265-053 Copyright 2017 by DiPrete Engineering Associates, Inc.

General Notes:

- 1. THE SITE IS LOCATED ON THE TOWN OF SOUTH KINGSTOWN ASSESSOR'S PLAT 40-4 LOT 55.
2. THE SITE IS APPROXIMATELY 28.06± ACRES AND IS ZONED R-20.
3. THE OWNER OF AP 40-4 LOT 55 IS: 5A BUILDERS, LLC
15 ROBERTSON ROAD
NARRAGANSETT, RI 02882
4. THIS SITE IS LOCATED IN FEMA FLOOD ZONES X (SHADED) AND ZONE X (UNSHADED). REFERENCE FEMA FLOOD INSURANCE RATE MAP 44090C0184K MAP REVISED APRIL 3, 2020. (FLOOD PLAN DESCRIPTIONS SHOWN BELOW)
ZONE X (UNSHADED) - THIS SITE IS LOCATED IN FEMA FLOOD ZONE X. ZONE X ARE AREAS WHERE THERE IS MINIMAL FLOODING.
ZONE X (SHADED) - THIS SITE IS LOCATED IN FEMA FLOOD ZONE X. ZONE X ARE AREAS OF 0.2% ANNUAL CHANCE OF FLOOD; AREAS OF 1% ANNUAL CHANCE OF FLOOD WITH AVERAGE DEPTHS OF LESS THAN 1 FOOT OR WITH DRAINAGE AREAS LESS THAN 1 SQUARE MILE; AND AREAS PROTECTED BY LEVEES FROM 1% ANNUAL CHANCE FLOOD.
5. THE OVERALL PERIMETER LINE AS SHOWN ON THE ENGINEERING PLANS DEPICTS THE RESULTS OF A CLASS I BOUNDARY RETRACEMENT SURVEY AS PERFORMED BY DIPRETE ENGINEERING ASSOCIATES, INC. THESE PLANS ARE NOT TO BE CONSTRUCTED AS A CLASS I BOUNDARY RETRACEMENT SURVEY PLAN AND IS NOT SUITABLE FOR RECORDING AS A CLASS I STANDARD SURVEY PLAN.
6. CONTOUR DATA SHOWN ON THESE PLANS CONFORMS TO A T-2 DATA ACCUMULATION SURVEY (LIMITED) OBTAINED VIA SURVEY BY DIPRETE ENGINEERING ON OCTOBER 17, 2016, SUPPLEMENTED BY A T-4 TOPOGRAPHICAL SURVEY STANDARD AS ADOPTED BY THE RHODE ISLAND BOARD OF REGISTRATION FOR PROFESSIONAL LAND SURVEYORS; SAID DATA IS BASED ON ELEVATION INFORMATION THAT WAS COLLECTED WITH AIRBORNE LIDAR TECHNOLOGY FOR THE ENTIRE AREA OF RHODE ISLAND BETWEEN APRIL 22 AND MAY 6, 2011 AS PART OF THE NORTHEAST LIDAR PROJECT. THIS DATA'S POSITIONAL ACCURACY AND RELIABILITY HAS NOT BEEN VERIFIED BY DIPRETE ENGINEERING AND IS SUBJECT TO CHANGES AN AUTHORITY'S FIELD SURVEY MAY DISCLOSE.
7. ALL WORK PERFORMED HEREIN IS TO BE GOVERNED BY CURRENT EDITIONS OF THE RHODE ISLAND STANDARD SPECIFICATION FOR ROAD AND BRIDGE CONSTRUCTION, TOWN OF SOUTH KINGSTOWN STANDARD SPECIFICATIONS AND DETAILS AND SPECIFICATIONS INCLUDED AS PART OF THE DRAWINGS. IN AREAS OF CONFLICT BETWEEN THE DIFFERENT SPECIFICATIONS, THE DESIGN PLANS AND PROJECT SPECIFICATIONS WILL TAKE PRECEDENCE OVER THE GENERAL SPECIFICATIONS AND THE DESIGN ENGINEER WILL INTERPRET THE CONSTRUCTION REQUIREMENT. THE CONTRACTOR IS ADVISED TO REQUEST FOR INFORMATION (RFI) FOR ANY AREAS OF CONFLICT BEFORE COMMITTING TO CONSTRUCTION.
8. THE SITE IS WITHIN A:
NATURAL HERITAGE AREA (RDEM): THE NATURAL HERITAGE AREA IS MAPPED ON THE ENTIRETY OF THE SITE WITH THE EXCEPTION OF THE EXTREME NORTHEAST AREA OF THE SITE, BASED ON THE RIDEM ENVIRONMENTAL RESOURCES MAPS ON THE ARC GIS WEB VIEWER. THE RESOURCES OF STATE CONCERN IN THIS AREA ARE SWAYING RUSH (STATE THREATENED), REVERSED OR RESUPINATE BLADDERWORT (STATE CONCERN), AND TRUMPET HONEYSUCKLE (STATE CONCERN). THE RESOURCE RADIUS IS CENTERED ON APPROXIMATELY THE SOUTHERN SHORE OF ASA POND.
9. THE FOLLOWING DOCUMENTS ARE CONSIDERED PART OF THE PROJECT PLANS AND THE CONTRACTOR/ OWNER MUST MAINTAIN THESE DOCUMENTS AS PART OF A FULL PLAN SET:
• SOIL EROSION AND SEDIMENT CONTROL PLAN (SESC). THE SESC CONTAINS THE FOLLOWING:
o EROSION CONTROL MEASURES
o SHORT TERM MAINTENANCE
o ESTABLISHMENT OF VEGETATIVE COVER
o CONSTRUCTION POLLUTION PREVENTION
o SEQUENCE OF CONSTRUCTION
• STORMWATER OPERATION AND MAINTENANCE PLAN (O&M). THE O&M CONTAINS:
o LONG TERM MAINTENANCE
o LONG TERM POLLUTION PREVENTION
10. THIS PLAN SET REFERENCES RIDOT STANDARD DETAILS (DESIGNATED AS RIDOT STD X.X.X.). RIDOT STANDARD DETAILS ARE AVAILABLE FROM RIDOT AND ONLINE AT: HTTP://WWW.DOT.RI.GOV/BUSINESS/CONTRACTORSANDCONSULTANTS.PHP.
11. THE SITE IS TO BE SERVICED BY PUBLIC WATER AND PUBLIC SEWER.
12. PROPOSED RIGHTS OF WAY ARE TO BE 40' WIDE WITH 24' WIDE PAVEMENT (11' TRAVEL LANES AND 1' CAPE COD BERM ON EACH SIDE) AND 4' WIDE CONCRETE SIDEWALK ON ONE SIDE.
13. THE DRAINAGE SYSTEM IS DESIGNED TO MEET THE TOWN OF SOUTH KINGSTOWN SUBDIVISION AND LAND DEVELOPMENT REGULATIONS WITH THE USE OF CATCH BASINS, CULVERTS, AND INFILTRATING BASINS. THE STORMWATER MANAGEMENT SYSTEM MEETS THE RIDEM BEST MANAGEMENT PRACTICES.
14. THE SITE IS PROPOSED TO BE BUILT IN 1 PHASE.
15. SOIL EVALUATIONS WERE COMPLETED BY DIPRETE ENGINEERING ON OCTOBER 17, 2016.
16. WETLANDS FLAGGED BY DIPRETE ENGINEERING AND LOCATED VIA SURVEY ON OCTOBER 17, 2016.
17. ANY PROPRIETARY PRODUCTS REFERENCED IN THIS PLAN SET ARE REPRESENTATIVE OF THE MINIMUM DESIGN REQUIREMENTS FOR THE PURPOSE IT PROPOSES TO SERVE. ALTERNATIVES TO ANY PROPRIETARY PRODUCT MAY BE SUBMITTED TO THE ENGINEER OF RECORD FOR CONSIDERATION, WHICH MUST BE ACCOMPANIED BY APPROPRIATE SPECIFICATION SHEETS/ DESIGN CALCULATIONS THAT DEMONSTRATE THE ALTERNATIVE(S) MEET THE MINIMUM DESIGN PARAMETERS OF THE PRODUCT SHOWN ON THE PLANS. NO ALTERNATIVES MAY BE USED WITHOUT THE WRITTEN APPROVAL OF THE ENGINEER OF RECORD.
18. THIS PLAN SET MAY REFERENCE AND/ OR INCLUDE REPRODUCTIONS OF PROPRIETARY PRODUCTS/ DETAILS BY OTHERS, AND/ OR THEIR ASSOCIATED SPECIFICATIONS. ANY REFERENCED OR REPRODUCED PROPRIETARY PRODUCT OR DETAIL BY OTHERS THAT IS SHOWN ON DIPRETE PLANS IS STRICTLY FOR INFORMATION/ SPECIFICATION PURPOSES ONLY. DIPRETE ENGINEERING DOES NOT WARRANT ANY PROPRIETARY PRODUCTS, DETAILS BY OTHERS OR THEIR RESPECTIVE DESIGNS. IF A DIPRETE ENGINEERING PLAN INCLUDES A PROPRIETARY PRODUCT/ DETAIL BY OTHERS (EITHER EXPLICITLY OR IMPLIED) AND IS STAMPED BY A REGISTERED PROFESSIONAL ENGINEER OF DIPRETE ENGINEERING, SAID STAMP DOES NOT EXTEND TO ANY PORTION OF THE PROPRIETARY PRODUCT/ DETAIL BY OTHERS OR ITS DESIGN.
19. ALL UTILITIES SHALL BE FIELD LOCATED BY THE SURVEYOR DURING CONSTRUCTION AND AS-BUILT DRAWINGS BY A RI PROFESSIONAL ENGINEER SHALL BE ACCURATELY PREPARED PRIOR TO ACCEPTANCE OF THE ROAD. NO PLAN WILL BE ACCEPTED BY DPS THAT DOES NOT ACCURATELY SHOW FIELD VERIFIED INFORMATION.

Soil Information:

(REFERENCE: SOIL MAPPING OBTAINED FROM RIGIS. SOIL GEOGRAPHIC DATA DEVELOPED BY THE RHODE ISLAND SOIL SURVEY PROGRAM IN PARTNERSHIP WITH THE NATIONAL COOPERATIVE SOIL SURVEY)

Table with 2 columns: SOIL NAME, DESCRIPTION. Rows include BmA*, BmB**, NbB**, NdB**, Rf, SWA, WCB.

NOTE: *PRIME FARMLAND
**FARMLAND OF STATEWIDE IMPORTANCE

Soil Erosion and Sedimentation Control Notes:

- 1. THE CONTRACTOR IS RESPONSIBLE FOR ALL SOIL EROSION AND SEDIMENT CONTROL ON SITE WHICH MUST BE CONSTRUCTED AND MAINTAINED IN ACCORDANCE WITH THE APPLICABLE REGULATIONS AND AUTHORITY HAVING JURISDICTION. THE CONTRACTOR IS TO NOTIFY THE DESIGN ENGINEER, THE DIRECTOR OF PUBLIC WORKS, THE TOWN ENGINEER, AND RHODE ISLAND DEPARTMENT OF ENVIRONMENTAL MANAGEMENT AT LEAST 48 HOURS PRIOR TO THE START OF CONSTRUCTION.
2. ALL EROSION CONTROL INCLUDING (BUT NOT LIMITED TO) TEMPORARY SWALES, TEMPORARY SEDIMENT TRAPS, ETC. TO BE INSTALLED PER THE LATEST EDITION OF THE RHODE ISLAND SOIL EROSION AND SEDIMENTATION CONTROL (RISESC) HANDBOOK AND THE SOIL EROSION & SEDIMENTATION CONTROL PLAN(S). NOTE THE SOIL EROSION AND SEDIMENT CONTROL SHOWN ON THESE PLANS ARE THE MINIMUM QUANTITY / TYPE OF EROSION CONTROL DEVICES AND MATERIALS DEEMED REQUIRED BY DIPRETE ENGINEERING TO MEET THE OBJECTIVES OF THE RISESC HANDBOOK, BUT IS CONSIDERED A GUIDE ONLY. ADDITIONAL MEASURES/ ALTERNATE CONFIGURATIONS MAY BE REQUIRED IN ORDER TO MEET THE RISESC HANDBOOK BASED ON FACTORS INCLUDING (BUT NOT LIMITED TO) SITE PARAMETERS, WEATHER, INSPECTIONS AND UNIQUE FEATURES. THE SESC WILL CONTINUE TO EVOLVE THROUGHOUT CONSTRUCTION/PHASES. PURSUANT TO NOTE 1 ABOVE, SESC REMAINS THE RESPONSIBILITY OF THE CONTRACTOR UNTIL THE SITE IS FULLY STABILIZED AND/ OR SESC RESPONSIBILITIES ARE ASSUMED BY THE OWNER IN WRITING.
3. TEMPORARY SWALES ARE TO BE USED TO CONTROL RUNOFF DURING CONSTRUCTION OF THE PROPOSED SITE WORKS. TEMPORARY SWALES TO BE VEGETATED AFTER CONSTRUCTION. EROSION CONTROL MATS ARE TO BE INSTALLED, IF NECESSARY, TO PREVENT EROSION AND SUPPORT VEGETATION. AFTER CONSTRUCTION IS COMPLETE AND TRIBUTARY AREAS TO THE SWALES HAVE BEEN STABILIZED, THE TEMPORARY SWALES ARE TO BE CLEARED AND FINAL DESIGN, INCLUDING INSTALLATION OF THE GRASS SWALE TO BE PER THE DESIGN PLANS.
4. ONCE THE SEDIMENT TRAPS ARE NO LONGER REQUIRED AND ALL TRIBUTARY AREAS HAVE BEEN STABILIZED, THE TEMPORARY SEDIMENTATION BASIN TO BE CLEARED AND BROUGHT TO FINAL DESIGN GRADES.
5. INLET PROTECTION IS TO BE INSTALLED ON ALL CATCH BASINS ONCE CONSTRUCTED.
6. FOR SEQUENCE OF CONSTRUCTION, PROJECT PHASING AND CONSTRUCTION PHASING SEE SESC PLAN.
7. CONTRACTOR MAY MODIFY SEQUENCE OF CONSTRUCTION WITH APPROVAL FROM DESIGN ENGINEER AND OWNER.
8. IF CONCRETE TRUCKS ARE WASHED OUT ON SITE, ALL WASHOUT MUST BE COMPLETED IN THE DESIGNATED CONCRETE WASHOUT AREA.

Demolition Notes:

- 1. CONTRACTOR TO OBTAIN ALL FEDERAL, STATE, AND MUNIICIPAL APPROVALS PRIOR TO THE START OF CONSTRUCTION.
2. CONTRACTOR TO PERFORM DAILY SWEEPING AT CONSTRUCTION ENTRANCE DURING DEMOLITION AND CONSTRUCTION TO MINIMIZE SEDIMENTS ON EXTERNAL STREETS.
3. ANY EXISTING BUILDING(S) AND PROPERTY PROPOSED TO REMAIN WHICH ARE DAMAGED BY THE CONTRACTOR MUST BE REPAIRED BY THE CONTRACTOR AT NO ADDITIONAL COST TO THE OWNER.
4. CONTRACTOR IS RESPONSIBLE FOR REMOVING AND LEGALLY DISPOSING (R&D) ALL MATERIALS INDICATED ON THE PLANS UNLESS SPECIFIED OTHERWISE HERE IN. R&D MATERIALS MUST INCLUDE BUT ARE NOT LIMITED TO PAVEMENT, GRAVEL, CATCH BASINS, MANHOLES, GRATES/FRAMES/COVERS, AND ANY EXCESS SOIL THAT IS NOT INCORPORATED INTO THE WORK.
5. IN ADDITION TO THOSE AREAS SPECIFICALLY DESIGNATED ON THE PLANS, ALL DISTURBED AREAS INCLUDING THE CONTRACTOR'S STOCKPILE AND STAGING AREAS WITHIN THE LIMIT OF WORK MUST BE RESTORED TO MATCH THE DESIGN PLANS.
6. CONTRACTOR MUST DOCUMENT LOCATION OF ALL SUBSURFACE UTILITIES REMAINING IN PLACE AFTER DEMOLITION (ACTIVE AND INACTIVE/ABANDONED). LOCATION MUST BE DOCUMENTED BY FIELD SURVEY OR SWING TIES. COPIES OF LOCATION DOCUMENTATION MUST BE PROVIDED TO THE OWNER FOLLOWING COMPLETION OF DEMOLITION AND PRIOR TO START OF NEW CONSTRUCTION. A MARKER MUST BE INSTALLED TO FINISH GROUND AT ALL INSTALLED CAPS/PLUGS. THE MARKER CAN BE A POST IN CONSTRUCTION AREAS OR PAINTED ON A PERMANENT SURFACE.

Traffic Notes:

- 1. ALL TRAFFIC CONTROL MUST CONFORM TO THE FEDERAL HIGHWAY ADMINISTRATION (FHWA) MANUAL ON UNIFORM TRAFFIC CONTROL DEVICES (MUTCD) CURRENT EDITION.
2. DURING CONSTRUCTION, TRAFFIC CONES ARE TO BE USED FOR SEPARATION OF ACTIVE TRAFFIC FROM WORK ZONE PER MUTCD REQUIREMENTS.
3. DURING CONSTRUCTION FLAGGERS MUST BE EMPLOYED TO ENSURE SAFETY FOR INTERACTION OF CONSTRUCTION VEHICLES AND ACTIVE TRAFFIC.
4. ALL SIGNS, FLAGGERS, TRAFFIC CONTROL DEVICES, AND TEMPORARY TRAFFIC ZONE ACTIVITIES MUST MEET THE REQUIREMENTS OF THE MANUAL ON UNIFORM TRAFFIC (MUTCD) LATEST EDITION AND SUBSEQUENT ADDENDA.
5. TEMPORARY CONSTRUCTION SIGNS MUST BE MOUNTED ON TOWN-APPROVED SUPPORTS AND MUST BE REMOVED OR COVERED WHEN NOT APPLICABLE.

As-Built Notes:

ALL COMPONENTS OF THE DRAINAGE, SEWER, AND WATER SYSTEMS MUST BE AS-BUILT PRIOR TO COVERING. ENGINEER TO BE NOTIFIED PRIOR TO COVERING TO SURVEY AS-BUILT LOCATIONS. ENGINEER WILL NOT ACCEPT FIELD MEASUREMENTS FROM THE SITE CONTRACTOR.

Layout and Materials:

- 1. DIMENSIONS ARE FROM THE FACE OF CURB, FACE OF BUILDING, FACE OF WALL, AND CENTER LINE OF PAVEMENT MARKINGS, UNLESS OTHERWISE NOTED.
2. CURBING TO BE BITUMINOUS BERM OR AS LABELED ON THE PLANS.
3. SIDEWALK TO BE CONCRETE OR AS LABELED ON THE PLANS.
4. SYMBOLS AND LEGENDS OF PROJECT FEATURES ARE GRAPHIC REPRESENTATIONS AND ARE NOT NECESSARILY SCALED TO THEIR ACTUAL DIMENSIONS OR LOCATIONS ON THE DRAWINGS. THE CONTRACTOR MUST REFER TO THE DETAIL SHEET DIMENSIONS, MANUFACTURERS' LITERATURE, SHOP DRAWINGS AND FIELD MEASUREMENTS OF SUPPLIED PRODUCTS FOR LAYOUT OF THE PROJECT FEATURES.
5. SEE ARCHITECTURAL DRAWINGS FOR EXACT BUILDING DIMENSIONS AND DETAILS CONTIGUOUS TO THE BUILDING, INCLUDING SIDEWALKS, RAMPS, BUILDING ENTRANCES, STAIRWAYS, UTILITY PENETRATIONS, CONCRETE DOOR PADS, COMPACTOR PAD, LOADING DOCKS, BOLLARDS, ETC.
6. PROPOSED BOUNDS AND ANY EXISTING PROPERTY LINE MONUMENTATION DISTURBED DURING CONSTRUCTION MUST BE SET OR RESET BY A PROFESSIONAL LICENSED SURVEYOR.
7. CONTRACTOR MUST NOT RELY SOLELY ON ELECTRONIC VERSIONS OF PLANS, SPECIFICATIONS, AND DATA FILES THAT ARE OBTAINED FROM THE DESIGNERS. CONTRACTOR MUST VERIFY LOCATION OF PROJECT FEATURES IN ACCORDANCE WITH THE STAMPED PAPER COPIES OF THE PLANS AND SPECIFICATIONS THAT ARE SUPPLIED AS PART OF THE CONTRACT DOCUMENTS.

Grading and Utility Notes:

- 1. CONSTRUCTION TO COMMENCE FALL 2020 OR UPON RECEIPT OF ALL NECESSARY APPROVALS.
2. THE CONTRACTOR MUST COORDINATE WITH ALL OF THE APPROPRIATE UTILITY COMPANIES FOR AGREEMENTS TO SERVICE THE PROPOSED BUILDING. THIS MUST BE DONE PRIOR TO CONSTRUCTION. NO REPRESENTATIONS ARE MADE BY DIPRETE ENGINEERING THAT UTILITY SERVICE IS AVAILABLE.
3. THE CONTRACTOR IS RESPONSIBLE FOR DETERMINING FINISH GRADING AND DRAINAGE AROUND THE BUILDING TO ENSURE SURFACE WATER AND/OR GROUNDWATER ARE DIRECTED AWAY FROM THE STRUCTURE.
4. PRIOR TO START OF CONSTRUCTION, CONTRACTOR MUST VERIFY EXISTING PAVEMENT ELEVATIONS AT INTERFACE WITH PROPOSED PAVEMENTS, AND EXISTING GROUND ELEVATIONS ADJACENT TO DRAINAGE OUTLETS TO ASSURE PROPER TRANSITIONS BETWEEN EXISTING AND PROPOSED FACILITIES. CONTRACTOR MUST NOTIFY DESIGN ENGINEER OF ANY DISCREPANCIES PRIOR TO CONSTRUCTION.
5. ALL PROPOSED UNDERGROUND UTILITIES SERVING THE SITE AND BUILDINGS TO BE COORDINATED WITH OWNER, ARCHITECT, AND ENGINEER PRIOR TO INSTALLATION.
6. ALL RETAINING WALLS AND STEEP SLOPES ARE SUBJECT TO FINAL STRUCTURAL DESIGN. DIPRETE ENGINEERING IS NOT PROVIDING THE STRUCTURAL DESIGN OF THESE ITEMS. ALL WALLS AND STEEP SLOPES ARE TO BE DESIGNED AND BUILT UNDER THE DIRECTION OF A RHODE ISLAND LICENSED PROFESSIONAL ENGINEER SUITABLY QUALIFIED IN GEOTECHNICAL ENGINEERING AND CERTIFIED TO THE OWNER PRIOR TO THE COMPLETION OF THE PROJECT. SHOP DRAWINGS TO BE SUBMITTED PRIOR TO CONSTRUCTION. FINAL STRUCTURAL DESIGN MUST INCORPORATE THE INTENT OF THE GRADING SHOWN ON THESE PLANS AND ALL WORK MUST BE WITHIN THE LIMIT OF DISTURBANCE SHOWN ON THE PLANS.
7. ALL CUT AND FILL AREAS ARE TO BE DONE UNDER THE DIRECTION OF A PROFESSIONAL GEOTECHNICAL ENGINEER WITH TESTING AND CERTIFICATION TO BE PROVIDED TO THE APPLICANT AT THE COMPLETION OF THE PROJECT. DIPRETE ENGINEERING IS NOT PROVIDING THE FILL SPECIFICATION, GEOTECHNICAL ENGINEERING, STRUCTURAL ENGINEERING SERVICES, OR SUPERVISION AS PART OF THESE DRAWINGS.
8. NO STOCKPILING OF MATERIAL TO BE LOCATED IN THE RIGHT OF WAY AND NO OPEN TRENCHES ARE TO BE LEFT OVERNIGHT.
9. ALL LOAM IN DISTURBED AREAS TO BE STOCKPILED FOR FUTURE USE.
10. ALL EXCESS SOIL, TREES, ROCKS, BOULDERS, AND OTHER REFUSE, MUST BE DISCARDED OFF SITE IN AN ACCEPTABLE MANNER AT AN APPROVED LOCATION. STUMPS MUST BE GROUND ON SITE OR REMOVED.
11. THE SITE WILL HAVE 3" BITUMINOUS BERM. SITE GRADING/CONTOURS SHOWN ON THE PLANS DO NOT NECESSARILY REFLECT THE APPROPRIATE BERM REVEAL. CONTRACTOR TO INSTALL CURBING WITH APPROPRIATE REVEAL UNLESS OTHERWISE NOTED.
12. NO STUMP DUMPS ARE PROPOSED ON SITE.

DRAINAGE

- ALL DRAINAGE PIPING WITHIN THE (FUTURE) TOWN RIGHT OF WAY SHALL BE REINFORCED CONCRETE (RCP).
DRAINAGE STRUCTURES TO BE AS FOLLOWS (UNLESS OTHERWISE NOTED ON PLANS):
• CATCH BASINS ALONG CURBING TO BE RIDOT STD. 4.4.0, TYPE F FRAME, 4' DIAMETER WITH APRON STONE.
• CATCH BASINS NOT ALONG CURBING TO BE RIDOT STD 4.4.0, 4' DIAMETER
• CATCH BASINS TO HAVE 3' SWIMS WITHOUT WEEPHOLES.
• SINGLE FRAME CATCHBASIN GRATES TO BE RIDOT STD. 6.3.2
• DOUBLE FRAME CATCHBASIN GRATES TO BE RIDOT STD. 6.3.2
• HIGH CAPACITY CATCHBASIN GRATES TO BE RIDOT STD 6.3.4 AND INSTALLED ANYWHERE GRADES ARE 6% AND STEEPER
• MANHOLES TO BE RIDOT STD. 4.2.0, 4.2.1 OR 4.2.2 AS REQUIRED
• DRAINAGE MANHOLE COVERS TO BE RIDOT STD 6.2.1
• DROP INLETS TO BE RIDOT STD. 4.5.0, 4.5.1 OR 4.5.2.
• APRON STONE, WHERE REQUIRED, TO BE RIDOT STD 7.1.7 OR 7.1.8.
• HEADWALLS TO BE RIDOT STD 2.1.0.
ALL DRAINAGE STRUCTURES MUST BE WATER TIGHT.

DRAINAGE CONNECTIONS FROM ALL DOWNSPOUTS (DS) ARE SHOWN FOR SCHEMATIC PURPOSES ONLY. THE LEVEL OF DETAIL SHOWN DOES NOT INCLUDE ALL JOINTS THAT MAY BE REQUIRED FOR CONSTRUCTION. ALL FITTINGS & PIPE SLOPES TO THE INTO MAIN TRUNK LINE OR DRYWELLS TO BE FIELD FIT BY CONTRACTOR.

SANITARY SEWER

ALL SANITARY SEWER PIPING TO BE SDR 35 UNLESS NOTED OTHERWISE ON THE PLANS OR IN THE SPECIFICATIONS. ALL SEWER IMPROVEMENTS MUST COMPLY WITH THE SOUTH KINGSTOWN WASTEWATER ORDINANCE AND ANY APPLICABLE AUTHORITY HAVING JURISDICTION, INCLUDING (BUT NOT LIMITED TO) MATERIALS, DIMENSIONS AND ACCESS COVERS. CONTRACTOR MUST SUBMIT SHOP DRAWINGS FOR APPROVAL BY ENGINEER OF RECORD PRIOR TO CONSTRUCTION.

WATER

ALL WATER MAINS TO BE CONCRETE LINED DUCTILE IRON PIPE (CLOIP). ALL WATER MAIN IMPROVEMENTS MUST COMPLY WITH THE SOUTH KINGSTOWN WATER ORDINANCE AND ANY APPLICABLE AUTHORITY HAVING JURISDICTION, INCLUDING (BUT NOT LIMITED TO) MATERIALS, DIMENSIONS AND ACCESS COVERS. CONTRACTOR TO PROVIDE SHOP DRAWINGS AND SUBMITTALS TO THE ENGINEER OF RECORD FOR APPROVAL FOR ALL WATER IMPROVEMENTS AND APPURTENANCES INCLUDING BUT NOT LIMITED TO PIPES, VALVES, FITTINGS, HEAT ENCLOSURES, AND BACKFLOWS. ALL COMPONENTS OF THE WATER SYSTEM TO BE ASBUILT PER THE SOUTH KINGSTOWN WATER ORDINANCE. ALL COMPONENTS OF THE WATER SYSTEM TO BE INSPECTED BY SUEZ WATER. CONTRACTOR TO COORDINATE ALL IMPROVEMENTS WITH SUEZ WATER TO ENSURE INSPECTOR IS ON SITE.

IN THE CASE OF ANY NEW HYDRANT INSTALLED IN OR NEXT TO AN EXISTING SIDEWALK, THE CONTRACTOR MUST INCREASE THE WIDTH OF THE SIDEWALK, AS NECESSARY, TO MAINTAIN A MINIMUM OF 3'-0" CLEAR WIDTH FROM THE OUTERMOST COMPONENTS OF THE HYDRANT TO THE EDGE OF THE SIDEWALK. THE 3'-0" SIDEWALK WIDTH IS REQUIRED ONLY ON ONE SIDE OF THE HYDRANT TO PROVIDE A CLEAR PATH ON THE SIDEWALK.

ELECTRIC/TELECOM/GAS

PROPOSED GAS, ELECTRIC, CABLE AND DATA UTILITIES ARE SHOWN SCHEMATICALLY AND ARE PROPOSED TO BE UNDERGROUND. OWNER & CONTRACTOR TO COORDINATE FINAL DESIGN WITH APPROPRIATE UTILITY COMPANIES. ALL WORK TO BE IN ACCORDANCE WITH EACH UTILITY COMPANY'S STANDARDS AND DETAILS AS WELL AS LOCAL AND FEDERAL REGULATIONS. THIS INCLUDES BUT IS NOT LIMITED TO POLES, TRANSFORMERS, PULL BOXES, CONCRETE PADS, CONCRETE ENCASEMENTS AND CONDUITS. CONNECTION POINTS FOR ELECTRIC AND TELECOM UTILITIES, AT THE EXISTING INFRASTRUCTURE, ARE CURRENTLY SHOWN AS UNDERGROUND UTILITIES. THESE UTILITIES MAY BE UNDERGROUND OR OVERHEAD AND WILL BE COORDINATED WITH NATIONAL GRID PRIOR TO CONSTRUCTION.

SITE LIGHTING

SITE LIGHTING (TEMPORARY AND PERMANENT) MUST BE DIRECTED AWAY FROM AND SHIELDED FROM ENVIRONMENTALLY SENSITIVE AREAS AND ABUTTING LANDS. EXACT LOCATIONS OF LIGHT POLE TO BE COORDINATED WITH OTHER UTILITIES AND TO BE LOCATED WITHIN THE STREET RIGHTS OF WAY. FINAL LIGHTING AND CONDUIT LOCATIONS BY OTHERS.

Abbreviations Legend

Table listing abbreviations and their meanings: ADA, AHJ, AP, BC, BTM, BIT, BIO, BS, BW, CB, (C), (C), CL, (CA), CLDIP, CO, CONC, (D), DCB, DI, DIP, DMH, DP, ELEV, EOP, ESC, EX, FES, FFE, GS, GWT, HW, HC, HOPE, ID, INV, IP, LF, LOD, LP, (M), N/F, OHW, PE, P, PR, PVC, R, R&D, RCP, RIHB, RLB, ROW, S, SD, SED, SF, SFL, SPM, SG, SHL, SMH, SNDF, SS, STA, TC, TD, TF, TRANS, TW, TYP, UDS, UIS, INFIL, WO, WQ, OVERHEAD WIRE, POLYETHYLENE, PROPERTY LINE, PROPOSED, POLYVINYL CHLORIDE, BUILDING, REMOVE AND DISPOSE, REINFORCED CONCRETE PIPE, RHODE ISLAND, HIGHWAY BOUND, ROOF LEADER, RIGHT OF WAY, SUBDRAIN, SEDIMENT FOREBAY, SQUARE FOOT, STATE FREEWAY LINE, SEWER FORCE MAIN, SLAB ON GRADE ELEVATION, STATE HIGHWAY LINE, SEWER MANHOLE, SAND FILTER, SIDE SLOPE, STATION, TOP OF CURB, TRENCH DRAIN, TOP OF FOUNDATION TRANSITION, GRADE OF WALL (FINISHED), TOP OF WALL, TYPICAL, UNDERGROUND, DETENTION SYSTEM, UNDERGROUND INFILTRATION SYSTEM, UTILITY POLE, WALKOUT ELEVATION, WATER QUALITY.

Americans with Disabilities Act Notes:

- 1. ALL IMPROVEMENTS MUST COMPLY WITH THE "AMERICANS WITH DISABILITIES ACT ACCESSIBILITY GUIDELINES (ADAAG)" BY THE DEPARTMENT OF JUSTICE (CURRENT EDITION).
2. MAXIMUM RUNNING SLOPE ALONG ALL ACCESSIBLE PATHS OF TRAVEL MUST BE 4.5% (0.045 FT/FT), AND MAXIMUM CROSS SLOPE ACROSS ALL ACCESSIBLE PATHS OF TRAVEL MUST BE 1.5% (0.015 FT/FT).
3. ADA PARKING SPACES AND LOADING AREAS: THE STEEPEST SLOPE OF THE SPACE, MEASURED IN ANY DIRECTION (INCLUDING DIAGONAL), MUST BE LESS THAN OR EQUAL TO 2% (0.02 FT/FT). DIPRETE ENGINEERING GENERALLY RECOMMENDS A MAXIMUM OF 1.4% (0.014 FT/FT) BE USED FOR BOTH RUNNING AND CROSS SLOPES IN ORDER TO COMPLY.
4. NOTWITHSTANDING THE NOTES LISTED ABOVE, TOWN OR STATE-SPECIFIC STANDARDS MAY BE MORE STRINGENT AND OVERRULE. IT IS THE RESPONSIBILITY OF THE USER OF THIS PLAN SET TO MAINTAIN COMPLIANCE WITH THE CONTROLLING STANDARD.
5. NOTE THAT THE GRADING/ PLAN VIEWS AND DETAILS CONTAINED WITHIN THIS PLAN SET MAY NOT SHOW THE DETAIL NECESSARY TO CONSTRUCT WALKWAYS, RAMPS AND SPACES TO COMPLY WITH THE ABOVE REQUIREMENTS. THE CONTRACTOR IS RESPONSIBLE TO PROVIDE THE LEVEL OF CARE NECESSARY TO BE CERTAIN THAT THE CONSTRUCTED PRODUCT MEETS ADA/ CONTROLLING STANDARDS. IN THE EVENT OF ANY NON COMPLIANCE THE CONTRACTOR MUST NOTIFY THE DESIGNER BEFORE CONSTRUCTION FOR ADVICE IN FINDING A RESOLUTION.

Site Callouts Legend

Table listing site callouts: (7.1.0) RIDOT STD PRECAST CONCRETE CURB, (7.1.2) RIDOT STD 6'-0" PRECAST CONCRETE TRANSITION CURB, (43.1.0) RIDOT STD CEMENT CONCRETE SIDEWALK, (12W) STOP LINE (REFERENCE MUTCD SECTION 3B.16)

Existing Legend

(AS SHOWN ON PROPOSED PLANS)

NOT ALL ITEMS SHOWN WILL APPEAR ON PLANS

Table listing existing legend symbols and their meanings: PROPERTY LINE, ASSESSORS LINE, BUILDING, BRUSHLINE, TREE LINE, GUARDRAIL, FENCE, RETAINING WALL, STONE WALL, MINOR CONTOUR LINE, MAJOR CONTOUR LINE, WATER LINE, SEWER LINE, SEWER FORCE MAIN, GAS LINE, ELECTRIC LINE, OVERHEAD WIRES, DRAINAGE LINE, SOILS LINES, 50' PERIMETER WETLAND, 100' RIVERBANK WETLAND, 200' RIVERBANK WETLAND, FEMA BOUNDARY, STREAM, NAIL FOUND/SET, DRILL HOLE FOUND/SET, BOUND FOUND/SET, SIGN, BOLLARD, SOIL EVALUATION, CATCH BASIN, DOUBLE CATCH BASIN, DMB DRAINAGE MANHOLE, FES FLARED END SECTION, GUY POLE, ELECTRIC MANHOLE, UP UTILITY/POWER POLE, LIGHTPOST, SEWER/SEPTIC MANHOLE, SEWER VALVE, CLEANOUT, HYDRANT, IRRIGATION VALVE, WATER VALVE, WELL, MONITORING WELL, UNKNOWN MANHOLE, GAS VALVE, BENCH MARK, STREAM FLOW DIRECTION.

Proposed Legend

NOT ALL ITEMS SHOWN WILL

Table listing proposed legend symbols and their meanings: PROPERTY LINE, BUILDING SETBACKS, CHAINLINK FENCE, STONE OR LANDSCAPE DIVIDER BETWEEN ROADWAY AND SAND FILTER B, RETAINING WALL, MINOR CONTOUR LINE, MAJOR CONTOUR LINE, SPOT ELEVATION, EDGE OF PAVEMENT, BITUMINOUS BERM, CONCRETE CURB (RIDOT STD 7.1.0), BUILDING FOOTPRINT, BUILDING OVERHANG, ASPHALT PAVEMENT, HEAVY DUTY ASPHALT PAVEMENT, HEAVY DUTY CONCRETE, CONCRETE, ASPHALT SIDEWALK, SAWCUT LINE, SIGN (RIDOT STD 24.6.2 AS APPLICABLE), SINGLE LIGHT, DOUBLE LIGHT, OVERHANGING LIGHT, ACCESSIBLE PARKING SPACE SYMBOLS, BUILDING INGRESS/EGRESS, DRAINAGE LINE, PERFORATED SUBDRAIN, SWALE, SEWER FORCE MAIN, GAS LINE, WATER LINE, HYDRANT ASSEMBLY, WATER SHUT OFF, WATER VALVE, THRUST BLOCK, SEWER LINE, OVERHEAD WIRE, CABLE LINE, LIMIT OF DISTURBANCE / LIMIT OF CLEARING, SEDIMENTATION BARRIER, SLOPE (RULY) COMPANES, COMPOST SOCK OR APPROVED EQUAL, SLOPES STEEPER THAN 3:1 (2:1 OR 1:1 SLOPES), UNDERGROUND INFILTRATION OUTLINE, POND ACCESS, RIPRAP, SAND FILTER, BIO RETENTION, CATCH BASIN, DOUBLE CATCH BASIN, MANHOLE, FLARED END SECTION, HEADWALL, CLEAN CHECK VALVE (SEWER), SEWER CLEANOUT.

Utility Note:

ALL UNDERGROUND UTILITIES SHOWN ON THESE PLANS WERE PROVIDED BY OTHERS AND ARE APPROXIMATE ONLY. LOCATIONS MUST BE DETERMINED IN THE FIELD BEFORE EXCAVATION, BLASTING, UTILITY INSTALLATION, BACKFILLING, GRADING, PAVEMENT RESTORATION, AND ALL OTHER SITE WORK. ALL UTILITY COMPANIES, PUBLIC AND PRIVATE, MUST BE CONTACTED INCLUDING THOSE IN CONTROL OF UTILITIES NOT SHOWN ON THESE DOCUMENTS. CONTACT DIG SAFE A MINIMUM OF 72 WORKING HOURS PRIOR TO ANY CONSTRUCTION AT 811. DIG SAFE IS RESPONSIBLE FOR CONTACTING MEMBER UTILITY COMPANIES. DIG SAFE MEMBER UTILITY COMPANIES ARE RESPONSIBLE TO MARK ONLY THE FACILITIES THAT THEY OWN OR MAINTAIN. NON DIG SAFE MEMBER COMPANIES ARE NOT NOTIFIED BY DIG SAFE. IT IS THE CONTRACTOR'S RESPONSIBILITY TO INVESTIGATE AND NOTIFY IF ANY PRIVATELY OWNED OR NON DIG SAFE MEMBER UTILITIES ARE IN THE AREA.
PER THE CODE OF FEDERAL REGULATIONS - TITLE 29, PART 1926 IT IS THE SITE CONTRACTOR'S RESPONSIBILITY TO OBTAIN ACCURATE UNDERGROUND UTILITY LINE LOCATIONS FROM THE UTILITY COMPANIES, UTILITY OWNERS AND, OR VIA UNDERGROUND UTILITY LOCATION EQUIPMENT AS NEEDED TO ESTABLISH ACCURATE LOCATIONS PRIOR TO ANY EXCAVATION. THE USE OF PROFESSIONAL UTILITY LOCATING COMPANIES PRIOR TO ANY EXCAVATION IS RECOMMENDED.

DIPRETE ENGINEERING IS NOT A PROFESSIONAL UTILITY LOCATION COMPANY, AND IS NOT RESPONSIBLE FOR UNDERGROUND UTILITIES, DEPICTED OR NOT, EITHER IN SERVICE OR ABANDONED. ANY SIZES, LOCATIONS, EXISTENCE, OR LACK OF EXISTENCE OF UTILITIES SHOWN ON THESE PLANS SHOULD BE CONSIDERED APPROXIMATE UNTIL VERIFIED BY A PROFESSIONAL UTILITY LOCATION COMPANY. DIPRETE ENGINEERING ASSUMES NO RESPONSIBILITY FOR DAMAGES INCURRED.

DiPrete Engineering logo and contact information: Two Stafford Court, Cranston, RI 02920, tel 401-943-1000 fax 401-646-6006 www.diprete-eng.com

KEVIN DEMERS REGISTERED PROFESSIONAL ENGINEER CIVIL



This regulatory submission set shall not be used for construction purposes unless stamped/ Issued for Construction and signed by a DiPrete Engineering representative.
The contractor is responsible for all of the means, methods, safety precautions and requirements, and OSHA compliance in the implementation of this plan and design.

Table with 4 columns: Date, Description, Drawn By, Design By. Rows include 10/29/2020, 11/04/2020, 11/04/2020, 11/04/2020.

General Notes And Legend The Village at Curtis Corner 5A Builders, LLC

General Notes

- THE PARCEL IS FOUND ON ASSESSOR'S PLAT 40-4, LOT 55 IN THE TOWN OF SOUTH KINGSTOWN, WASHINGTON COUNTY, RHODE ISLAND.
- THE OWNER PER DEED BOOK 1680, PAGE 270 IS SA BUILDERS, LLC.
- THE PARCEL IS LOCATED IN ZONE X & X SHADED PER FEDERAL EMERGENCY MANAGEMENT AGENCY FLOOD INSURANCE RATE MAP 440990184J, DATED OCTOBER 16, 2013.
- THE PARCEL IS ZONED R20 PER THE ASSESSOR'S ONLINE DATABASE. PLEASE CONTACT THE ZONING DEPARTMENT FOR ANY ADDITIONAL INFORMATION OR FOR A CERTIFICATE OF ZONING.
- THERE WERE NO CEMETERIES, GRAVE SITES AND OR BURIAL GROUNDS OBSERVED WITHIN THE LIMITS OF THE SURVEY.
- FIELD SURVEY PERFORMED BY DIPRETE ENGINEERING ON OCTOBER 17, 2016. THIS PLAN REFLECTS ON THE GROUND CONDITIONS AS OF THAT DATE.
- ALL UNDERGROUND UTILITIES SHOWN ON THIS PLAN HAVE BEEN LOCATED FROM FIELD SURVEY OBSERVATIONS ONLY. DIPRETE ENGINEERING IS NOT RESPONSIBLE FOR MISSING UNDERGROUND UTILITIES, EITHER IN SERVICE OR ABANDONED, NOT OBSERVED AT THE TIME OF THE SURVEY. (PLEASE CONTACT DIOSAFE 72 WORKING HOURS PRIOR TO ANY CONSTRUCTION AT 1-888-344-7233).
- THIS SURVEY WAS PREPARED WITHOUT THE BENEFIT OF A TITLE REPORT. DIPRETE ENGINEERING IS NOT RESPONSIBLE FOR ANY UNKNOWN OR UNRECORDED EASEMENTS, DEEDS OR CLAIMS THAT A TITLE REPORT WOULD DISCLOSE.
- THIS PARCEL IS LOCATED WITHIN A TMDL WATERSHED FOR FECAL COLIFORM ASSOCIATED WITH ROCKY BROOK AND TRIBUTARIES, AS IDENTIFIED BY THE RIDEM ENVIRONMENTAL RESOURCE MAP.
- THE SITE IS WITHIN A: NATIONAL HERITAGE AREA (RIDEM)
- THE SITE IS NOT WITHIN A: GROUNDWATER PROTECTION AREA (RIDEM) NARROW RIVER SPECIAL AREA MANAGEMENT PLAN (CRMC) SALT PONDS SPECIAL AREA MANAGEMENT PLAN (CRMC) GROUNDWATER PROTECTION OVERLAY DISTRICT (TOWN) OWTS CRITICAL RESOURCE AREA (RIDEM) DRINKING WATER SUPPLY WATERSHED (RIDEM) TMDL WATERSHED (RIDEM/TOWN)
- THE SUBDIVISION PARCEL AND ANY BUILDINGS WITHIN THE PARCEL ARE NOT LISTED ON THE NATIONAL REGISTER OF HISTORIC PLACES.
- THERE IS NO ACTIVE AGRICULTURAL USE PRESENT ON THE SITE.

Soil Information:

(REFERENCE: SOIL MAPPING OBTAINED FROM RIGIS. SOIL GEOGRAPHIC DATA DEVELOPED BY THE RHODE ISLAND SOIL SURVEY PROGRAM IN PARTNERSHIP WITH THE NATIONAL COOPERATIVE SOIL SURVEY)

SOIL NAME	DESCRIPTION
BmA*	BRIDGEHAMPTON SILT LOAM, TILL SUBSTRATUM, 0 TO 3 PERCENT SLOPES
BmB**	BRIDGEHAMPTON SILT LOAM, TILL SUBSTRATUM, 3 TO 8 PERCENT SLOPES
NaB*	NARRAGANSETT SILT LOAM, 3 TO 8 PERCENT SLOPES
NbB	NARRAGANSETT VERY STONY SILT LOAM, 0 TO 8 PERCENT SLOPES
Rf	RIDGEBURY, WHITMAN, AND LEICESTER EXTREMELY STONY FINE SANDY SWANSEA MUCK
SwA	WAPPING VERY STONY SILT LOAM, 0 TO 8 PERCENT SLOPES
WcB	

NOTE: *PRIME FARMLAND
**FARMLAND OF STATEWIDE IMPORTANCE

Plan References:

- "PLAT OF LAND IN SOUTH KINGSTOWN, RHODE ISLAND SURVEYED FOR ESTATE OF SAMUEL A. RODMAN" SCALE 1"=100' DATED FEBRUARY 24, 1950 PLAN BY: LEON L. HOLLAND.
- "SECTION FIVE, ROLLING ACRES, TOWN OF SOUTH KINGSTOWN, R.I., PROPERTY OF BOISVERTS AND FORTIN REALTY CO." SCALE: 1"=50' DATED: APRIL 1973, FILED: MAY 1, 1973. RECORDED IN TOWN OF SOUTH KINGSTOWN LAND EVIDENCE RECORDS IN BOOK 16, PAGE 1398.
- "PLAT OF LAND NEAR CURTIS CORNER KNOWN AS LEWIS P. DIMON PROPERTY" SCALE 1"=160', RECORDED IN TOWN OF SOUTH KINGSTOWN LAND EVIDENCE RECORDS IN PLAT BOOK 14, PAGE 1051.
- "PLAN SHOWING LAND OF BOISVERT & FORTIN REALTY CO. SOUTH KINGSTOWN, RHODE ISLAND" PLAN BY W&W LAND SURVEYORS INC. SCALE: 1"=50' DATED: AUGUST 1981. RECORDED IN TOWN OF SOUTH KINGSTOWN LAND EVIDENCE RECORDS IN PLAT BOOK 17, PAGE 1587.
- "ADMINISTRATIVE SUBDIVISION FOR AP 40-1 LOTS 3, 125 & 126 KINGSTOWN ROAD (ROUTE 108) IN SOUTH KINGSTOWN, RHODE ISLAND" OWNED BY SOUTH SHORE MENTAL HEALTH CENTER, INC. BY COMMONWEALTH ENGINEERS & CONSULTANTS, INC. SCALE 1"=30' REVISED: MAY 25, 2010 RECORDED IN TOWN OF SOUTH KINGSTOWN LAND EVIDENCE RECORDS IN PLAT BOOK C2010, PAGE 31.
- "FINAL PLAN OPEN SPACE USE PLAN ROLLING ACRES SECTION 7 A.P. 40-1, LOT 2 SOUTH KINGSTOWN, RHODE ISLAND" OWNER BOISVERT & FORTIN REALTY COMPANY, BY: ENVIRONMENTAL PLANNING & SURVEYING, INC REVISED: DECEMBER 14, 1999 RECORDED IN TOWN OF SOUTH KINGSTOWN LAND EVIDENCE RECORDS IN PLAT BOOK C2000, PAGE 60.
- "FINAL PLAN DEFINITIVE PLAN FOR ROLLING ACRES SECTION 7 A.P. 40-1, LOT 2 SOUTH KINGSTOWN, RHODE ISLAND" OWNER BOISVERT & FORTIN REALTY COMPANY, BY: ENVIRONMENTAL PLANNING & SURVEYING, INC REVISED: MARCH 23, 2000 RECORDED IN TOWN OF SOUTH KINGSTOWN LAND EVIDENCE RECORDS IN PLAT BOOK C2000, PAGE 59.
- "RECORD PLAN, CURTIS CORNER ROAD MINOR SUBDIVISION", APPLICANT/OWNER DAVID L. RODMAN. BY: DIPRETE ENGINEERING, SCALE 1" = 80', REVISED 5-14-2018. RECORDED IN TOWN OF SOUTH KINGSTOWN LAND EVIDENCE RECORDS IN MAP 2018-31.

Datum Note:

- ELEVATIONS SHOWN HEREON, IN U.S. SURVEY FEET, ARE REFERENCED TO THE NORTH AMERICAN VERTICAL DATUM OF 1988 (NAVD 88), AS DETERMINED BY DIPRETE ENGINEERING USING REAL TIME KINEMATIC G.P.S. OBSERVATIONS.

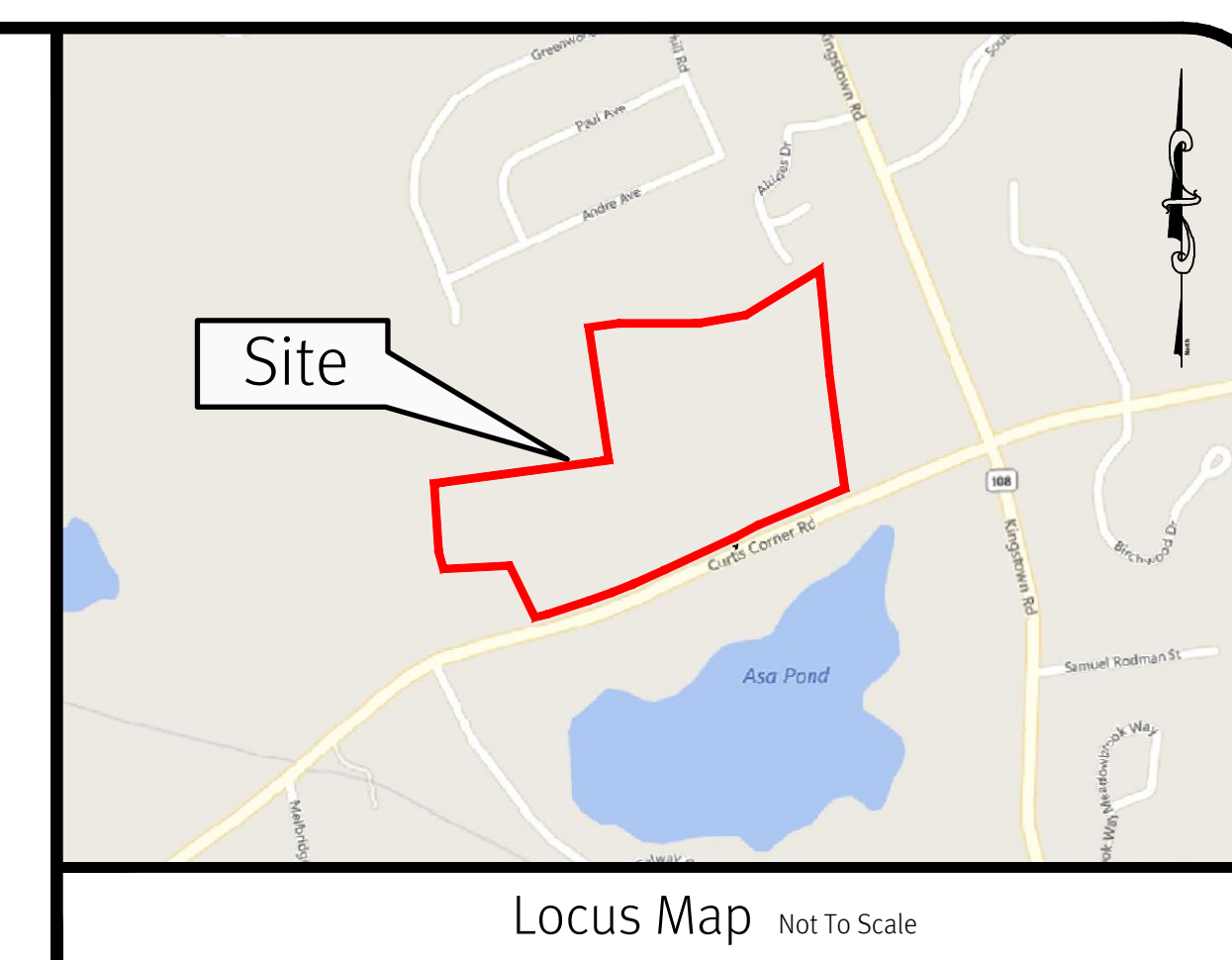

Locus Map Not To Scale

Legend
NOT ALL ITEMS SHOWN WILL APPEAR ON THE SURVEY

- | | |
|------|---------------------------------|
| | BUILDING |
| | ASPHALT |
| AP | ASSESSOR'S PLAT |
| N/F | NOW OR FORMERLY DEED - ADJOINER |
| (D) | MEASURED |
| (M) | CALCULATED |
| (C) | CHORD ANGLE |
| (CA) | HANDICAPPED PROPERTY LINE |
| HC | ASSESSORS LINE |
| | TREELINE |
| | GUARDRAIL |
| | FENCE |
| | RETAINING WALL |
| | STONE WALL |
| | MINOR CONTOUR LINE |
| | MAJOR CONTOUR LINE |
| | WATER LINE |
| | SEWER LINE |
| | SEWER FORCE MAIN |
| | GAS LINE |
| | ELECTRIC LINE |
| | OVERHEAD WIRES |
| | DRAINAGE LINE |
| | NAIL FOUND/SET |
| | DRILL HOLE FOUND/SET |
| | IRON ROD/PIPE FOUND/SET |
| | BOUND FOUND/SET |
| | SIGN |
| | BOLLARD |
| | SOIL EVALUATION |
| | CATCH BASIN |
| | DOUBLE CATCH BASIN |
| | DRAINAGE MANHOLE |
| | FLARED END SECTION |
| | GUY POLE |
| | ELECTRIC MANHOLE/HANDHOLE |
| | UTILITY/POWER POLE |
| | LIGHTPOST |
| | SEWER/SEPTIC MANHOLE |
| | SEWER VALVE |
| | CLEANOUT |
| | HYDRANT |
| | IRRIGATION VALVE |
| | WATER VALVE |
| | WELL |
| | MONITORING WELL |
| | UNKNOWN MANHOLE |
| | GAS VALVE |
| | WELL FLAG |
| | BENCH MARK |
| | BUSH |
| | TREE |

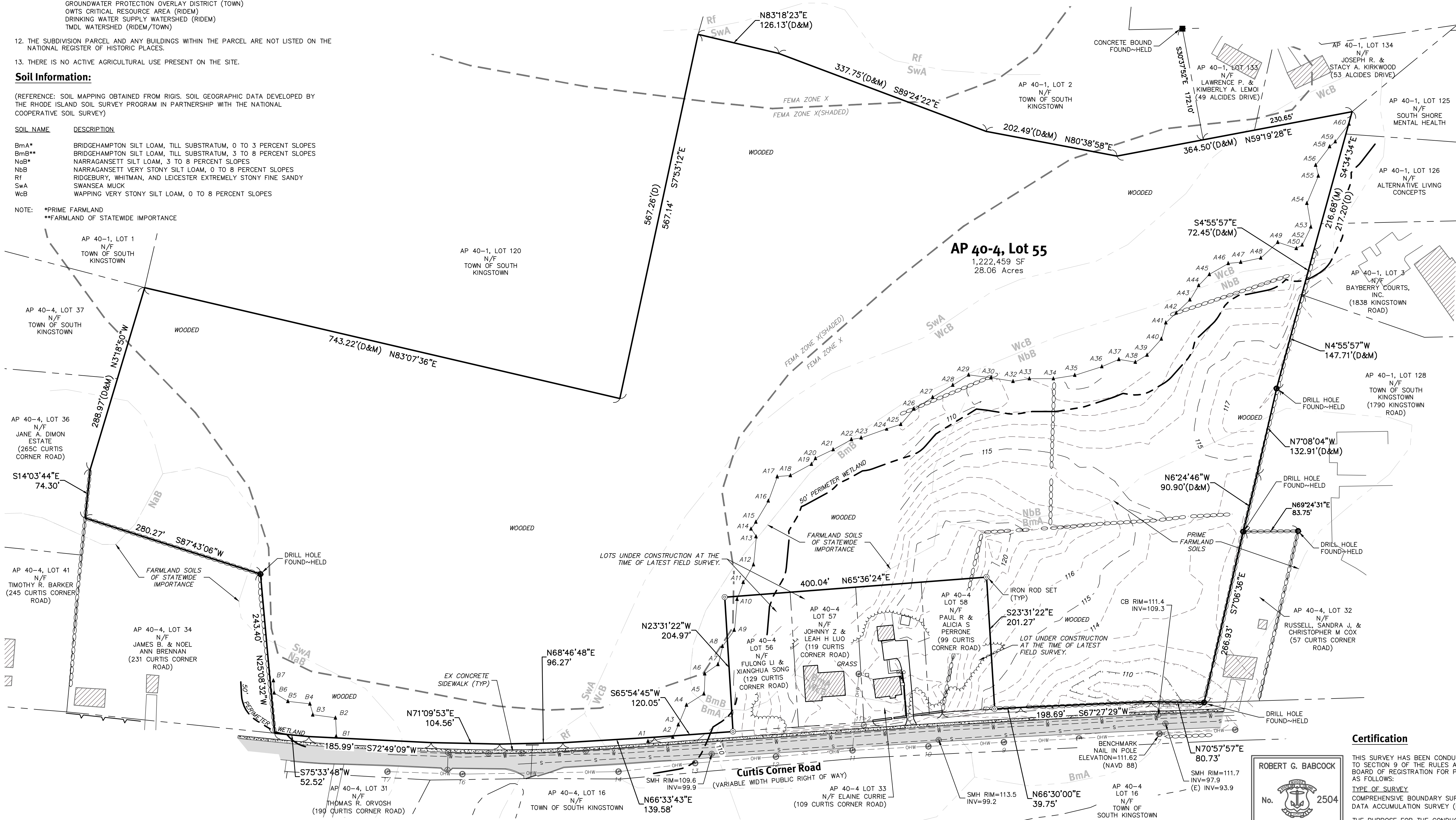

ROBERT G. BABCOCK
No. 2504
PROFESSIONAL LAND SURVEYOR

Certification
THIS SURVEY HAS BEEN CONDUCTED AND THE PLAN HAS BEEN PREPARED PURSUANT TO SECTION 9 OF THE RULES AND REGULATIONS ADOPTED BY THE RHODE ISLAND STATE BOARD OF REGISTRATION FOR PROFESSIONAL LAND SURVEYORS ON JANUARY 1, 2016, AS FOLLOWS:
TYPE OF SURVEY: COMPREHENSIVE BOUNDARY SURVEY
MEASUREMENT SPECIFICATION: CLASS 1
CLASSIFICATION: CLASS 1-2
THE PURPOSE FOR THE CONDUCT OF THE SURVEY AND FOR THE PREPARATION OF THE PLAN IS AS FOLLOWS:
PERIMETER RE-TRACEMENT PERFORMED BY DIPRETE ENGINEERING FOR THE PURPOSE OF SITE ENGINEERING AND PERMITTING.

ROBERT G. BABCOCK, RIPLS #2504, COA #LS.000A160
01-09-2020

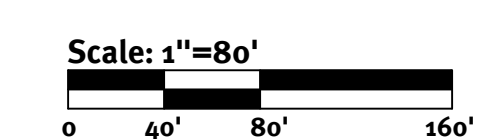

Diprete Engineering
Two Stafford Court Cranston, RI 02920
Tel: 401-943-1000 Fax: 401-641-6006 www.diprete-eng.com
Boston • Providence • Newport

ERIC M. DRIVE
No. 8662
REGISTERED PROFESSIONAL ENGINEER CIVIL

DATE	BY	DESCRIPTION
01/09/2020	Eric M. Drive	Boundary / Topographic Survey

Existing Conditions Plan
The Village at Curtis Corner
South Kingstown, Rhode Island
CLIENT: SA Builders, LLC
15 Robertson Road
Narragansett, RI 02882
SHEET 1 OF 1

C:\Users\eridrive\Documents\Projects\0365-053\curtis corner road\0365-053\curtis corner road.dwg Printed: 10/25/2020

GENERAL NOTES:

1. THE TEMPORARY SEDIMENT TRAP SHALL MEET ALL REQUIREMENTS FOR TEMPORARY SEDIMENT TRAPS OUTLINED IN THE RHODE ISLAND SOIL EROSION AND SEDIMENT CONTROL HANDBOOK (LATEST REVISION) SECTION SIX: SEDIMENT CONTROL MEASURES.
2. THE TEMPORARY SEDIMENT TRAP MUST PROVIDE A STORAGE VOLUME FOR ONE INCH OF RUNOFF FROM THE CONTRIBUTING AREA. HALF OF THE STORAGE MUST BE PROVIDED IN THE FORM OF WET STORAGE. SEE DETAIL BELOW SECTION 6 OF THE RISESCH.
3. ALL CUT AND FILL SLOPES MUST BE 2:1 OR FLATTER EXCEPT FOR THE EXCAVATED WET STORAGE AREA WHERE SLOPES MUST NOT EXCEED 1.5:1.
4. THE OUTLET MUST BE LOCATED AT THE MOST DISTANT HYDRAULIC POINT FROM THE INLET.
5. THE OUTLET CONSISTS OF A PERVIOUS STONE DIKE WITH A CORE OF MODIFIED RIPRAP AND FACED ON THE UPSTREAM SIDE WITH STONE.
6. TEMPORARY SEDIMENT TRAPS MUST OUTLET ONTO STABILIZED GROUND.
7. MAXIMUM HEIGHT OF A TEMPORARY SEDIMENT TRAP EMBANKMENT IS LIMITED TO 5 FEET (BOTTOM OF DRY STORAGE TO TOP OF EMBANKMENT). TOTAL EMBANKMENT HEIGHT MUST NOT EXCEED 6 FEET (BOTTOM OF WET STORAGE TO TOP OF EMBANKMENT).
8. SIDE SLOPES OF THE EMBANKMENT MUST BE 2:1 OR FLATTER.
9. MODIFIED RIPRAP: SHALL MEET THE REQUIREMENTS OF RIDOT STANDARD SPECIFICATIONS FOR ROAD AND BRIDGE CONSTRUCTION SUBSECTION M.10.03.2.
10. FILTER STONE: SHALL MEET THE REQUIREMENTS OF RIDOT STANDARD SPECIFICATIONS FOR ROAD AND BRIDGE CONSTRUCTION SUBSECTION M.01.03 TABLE I, COLUMN V FILTER STONE.

SEDIMENT TRAP DIMENSIONS*	TRAP A	TRAP B	TRAP C
TRIBUTARY DRAINAGE AREA	1.37 ac	1.26 ac	2.85 ac
WET STORAGE DEPTH (D _w)	1.00 ft	1.00 ft	2.50 ft
DRY STORAGE DEPTH (D _d)	1.00 ft	0.75 ft	1.50 ft
TOTAL DEPTH (D)	2.00 ft	1.75 ft	4.00 ft
BOTTOM OF TRAP AREA (A _b)	2599.42 sq.ft	1878.96 sq.ft	1272.87 sq.ft
WETTED SURFACE AREA (A _w)	3329.41 sq.ft	2761.26 sq.ft	2805.75 sq.ft
SURFACE AREA AT OUTLET (A _d)	4124.65 sq.ft	3429.16 sq.ft	3866.47 sq.ft

*TRAP DIMENSIONS REPRESENT MINIMUM REQUIRED SIZING TO MEET THE RISESCH. CONTRACTOR MAY SHAPE TRAP DIFFERENTLY THAN SHOWN ON PLANS AS LONG AS THE MINIMUM SIZING HAS BEEN PROVIDED.

MINIMUM TOP WIDTH VS HEIGHT

H (FT)	1.5	2.0	2.5	3.0	3.5	4.0	4.5	5.0
W (FT)	2.0	2.0	3.0	2.5	3.0	3.0	4.0	4.5

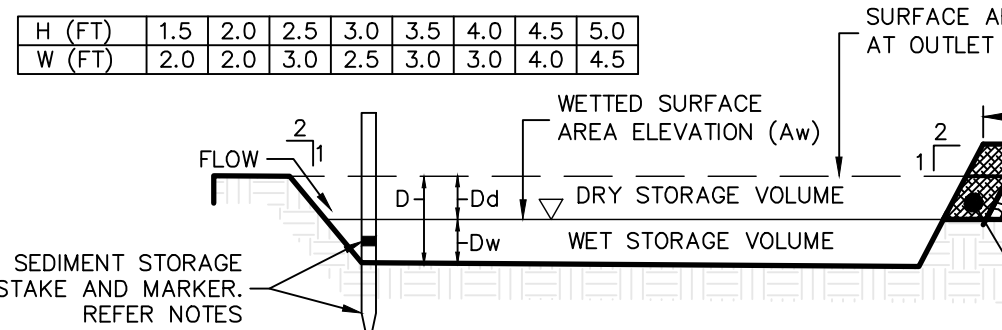

Temporary Sediment Trap Detail
NOT TO SCALE

INSPECTION, MAINTENANCE, AND REMOVAL REQUIREMENTS:

1. INSTALL "SEDIMENT STORAGE" STAKE WITH A MARKER AT ONE HALF OF THE WET STORAGE VOLUME.
2. INSPECT THE TEMPORARY SEDIMENT TRAP AT LEAST ONCE A WEEK AND WITHIN 24 HOURS OF THE END OF A STORM WITH A RAINFALL AMOUNT OF 0.25 INCH OR GREATER.
3. CHECK THE OUTLET TO ENSURE THAT IT IS STRUCTURALLY SOUND AND HAS NOT BEEN DAMAGED BY EROSION OR CONSTRUCTION EQUIPMENT.
4. CHECK FOR SEDIMENT ACCUMULATION AND FILTRATION PERFORMANCE.
5. WHEN SEDIMENTS HAVE ACCUMULATED TO ONE HALF THE MINIMUM REQUIRED VOLUME OF THE WET STORAGE, DEWATER THE TRAP AS NEEDED, REMOVE SEDIMENTS AND RESTORE THE TRAP TO ITS ORIGINAL DIMENSIONS.
6. DISPOSE OF THE SEDIMENT REMOVED FROM THE BASIN IN A SUITABLE AREA AS DESIGNATED BY THE GEOTECHNICAL ENGINEER.
7. THE TEMPORARY SEDIMENT TRAP MAY BE REMOVED AFTER THE CONTRIBUTING DRAINAGE AREA IS STABILIZED.

INSTALLATION NOTES:

1. CLEAR, GRUB AND STRIP ANY VEGETATION AND ROOT MAT FROM ANY PROPOSED EMBANKMENT AND OUTLET AREA.
2. REMOVE STONES AND ROCKS WHOSE DIAMETER IS GREATER THAN THREE (3) INCHES AND OTHER DEBRIS.
3. EXCAVATE WET STORAGE AND CONSTRUCT THE EMBANKMENT AND/OR OUTLET AS NEEDED TO ATTAIN THE NECESSARY STORAGE REQUIREMENTS.
4. USE ONLY FILL MATERIAL FOR THE EMBANKMENT THAT IS FREE FROM EXCESSIVE ORGANICS, DEBRIS, LARGE ROCKS (OVER SIX (6) INCHES) OR OTHER UNSUITABLE MATERIALS. COMPACT THE EMBANKMENT IN 8-INCH LAYERS BY TRAVERSING WITH EQUIPMENT WHILE IT IS BEING CONSTRUCTED.
5. STABILIZE THE EARTHEN EMBANKMENT USING ANY OF THE FOLLOWING MEASURES: SEEDING FOR TEMPORARY VEGETATIVE COVER; SEEDING FOR PERMANENT VEGETATIVE COVER; OR SLOPE PROTECTION, IMMEDIATELY AFTER INSTALLATION.

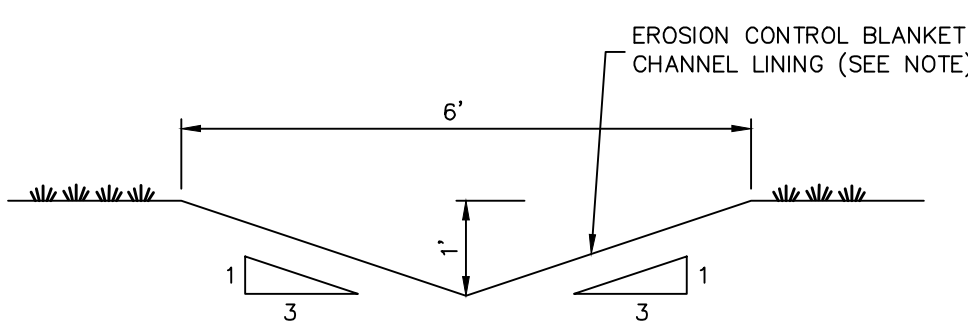

NOTE:

1. TEMPORARY EROSION CONTROL BLANKETS TO HANDLE MINIMUM VELOCITY OF 5 FPS. CONTRACTOR TO PROVIDE SHOP DRAWINGS TO DESIGN ENGINEER.
2. CONTRACTOR SHALL FIELD ADJUST TEMPORARY SWALES AS NECESSARY, AND ENSURE PROPER FLOW TO THE APPROPRIATE SEDIMENTATION PRACTICE.
3. SWALES TO BE ADJUSTED TO MAXIMIZE TRIBUTARY AREA TO EACH SEDIMENT TRAP PER DETAIL ABOVE.

Temporary Diversion Channel

NOT TO SCALE

Soil Erosion Control Implementation Phasing

- Phase IA** - INSTALL EROSION CONTROL SILT FENCE & STONE CONSTRUCTION ENTRANCE.
 - Phase IB** - INSTALL TEMPORARY SEDIMENTATION TRAP. CONSTRUCT CLEAN WATER DIVERSIONS.
 - Phase IC** - CONSTRUCT PROPOSED DIVERSIONS.
 - Phase IIA** - CLEAR AND GRUB IMPERVIOUS AREAS. INSTALL UTILITIES WITH ROADWAYS. INSTALL DRAINAGE NETWORK WORKING FROM THE DOWN GRAD BASINS UP TO THE START OF NETWORK. INSTALL ASPHALT PAVING.
 - Phase IIB** - STABILIZE ALL DISTURBED AREAS, DE-CONSTRUCT DIVERSIONS AND TEMPORARY SEDIMENTATION TRAPS.
 - Phase III** - CONSTRUCT DWELLINGS ON INDIVIDUAL LOTS. STABILIZE ANY TRIBUTARY AREAS DISTURBED DURING CONSTRUCTION OF UNITS.
 - Phase IV** - REPEAT III FOR INDIVIDUAL LOT PHASE.
- Note** - SOIL EROSION CONTROL IMPLEMENTATION PHASING SHOULD NOT BE MISCONSTRUED WITH CONSTRUCTION PHASING/ SEQUENCING. ALL MEASURES DEPICTED ON THIS PLAN ARE TO BE INSTALLED WITH THE FIRST PHASE OF CONSTRUCTION.

Soil Erosion Control Legend:

- DIVERSION RUNOFF CONVEYANCE MEASURE (SWALE AND/OR BERM)
- TEMPORARY SEDIMENT BASIN
- TEMPORARY SEDIMENT TRAP
- EROSION CONTROL (COMPOST SOCK, SILT FENCE (RI STD 9.2.0) OR APPROVED EQUAL)
- CLASS C SILT FENCE
- LIMIT OF DISTURBANCE (NO SEDIMENT CONTROL)
- LIMIT OF DISTURBANCE (WITH SEDIMENT CONTROL)
- TRIBUTARY AREA TO SESC BMP
- CONSTRUCTION ENTRANCE (RIDOT STD 9.9.0)
- INFILTRATING AREA (TO BE PROTECTED BY COMPOST SOCK OR SILT FENCE)
- FINAL CONTOUR GRADE
- INLET SEDIMENT CONTROL



Note: This Plan Must Be Reproduced In Color

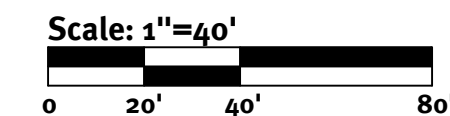

DiPrete Engineering
Two Stafford Court Cranston, RI 02920
Tel: 401-943-1000 Fax: 401-644-6006 www.diprete-eng.com

Boston • Providence • Newport

KEVIN DEMERS
REGISTERED PROFESSIONAL ENGINEER CIVIL



This regulatory submission set shall not be used for construction purposes unless stamped 'Issued for Construction' and signed by a DiPrete Engineering representative.

The contractor is responsible for all of the means, methods, safety precautions and requirements, and OSHA conformance in the implementation of this plan and design.

NO.	DATE	DESCRIPTION	BY	CHKD
1	10/29/2020	Preliminary Revisions	JDF	IMF
2	10/29/2020	Preliminary Revisions	JDF	IMF
3	10/29/2020	Preliminary Revisions	JDF	IMF
4	10/29/2020	Preliminary Revisions	JDF	IMF
5	10/29/2020	Preliminary Revisions	JDF	IMF
6	10/29/2020	Preliminary Revisions	JDF	IMF

Drawn By: IMF
Design By: C.H.D.

Soil Erosion & Sediment Control Plan
The Village at Curtis Corner
Assessors Plat 40-144-051
South Kingstown, Rhode Island
Application Owner:
5A Builders, LLC
220 Knowlesway Extension
Narragansett, RI 02882

DE Job No: 0265-053 Copyright 2017 by DiPrete Engineering Associates, Inc.

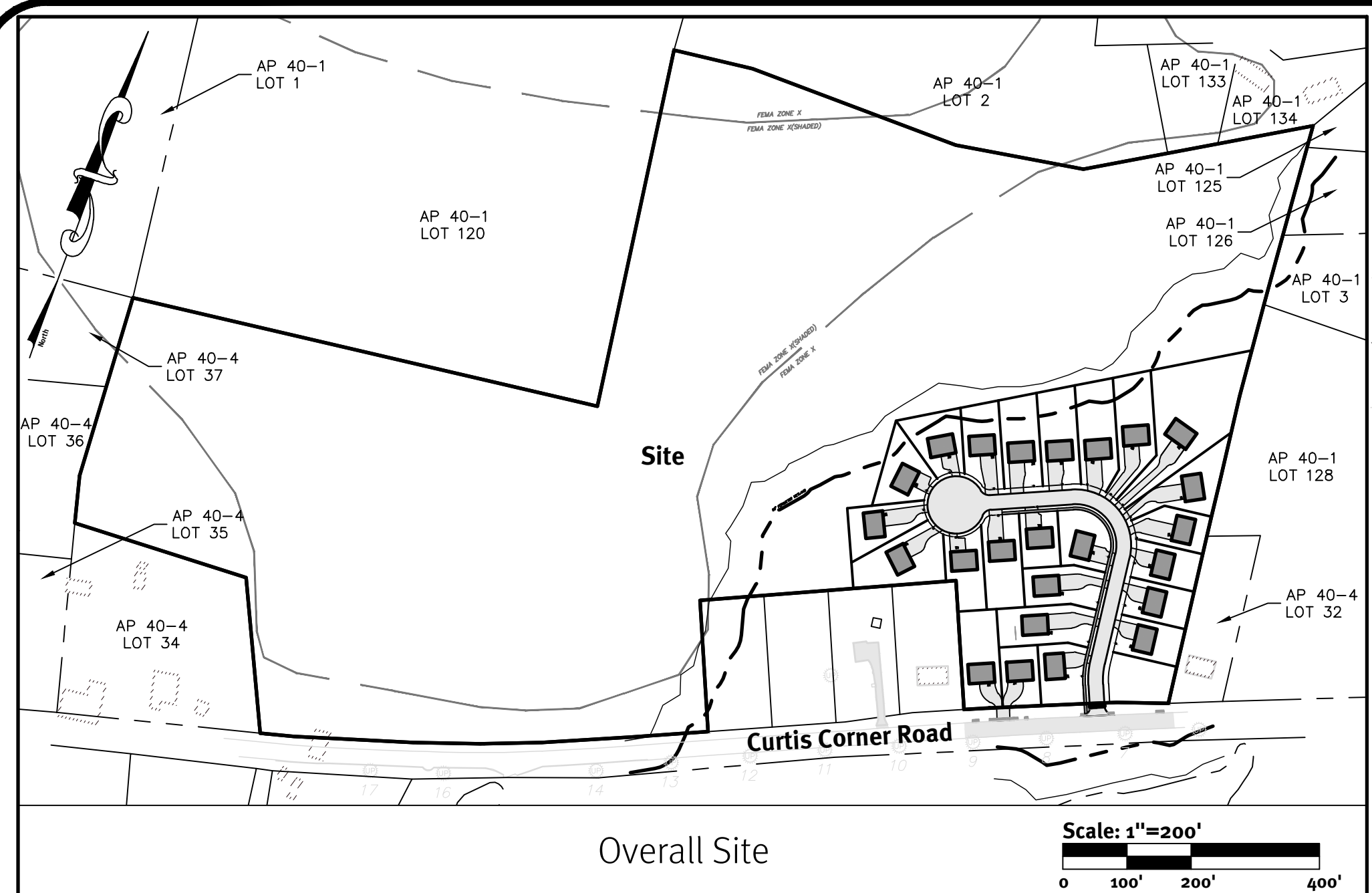
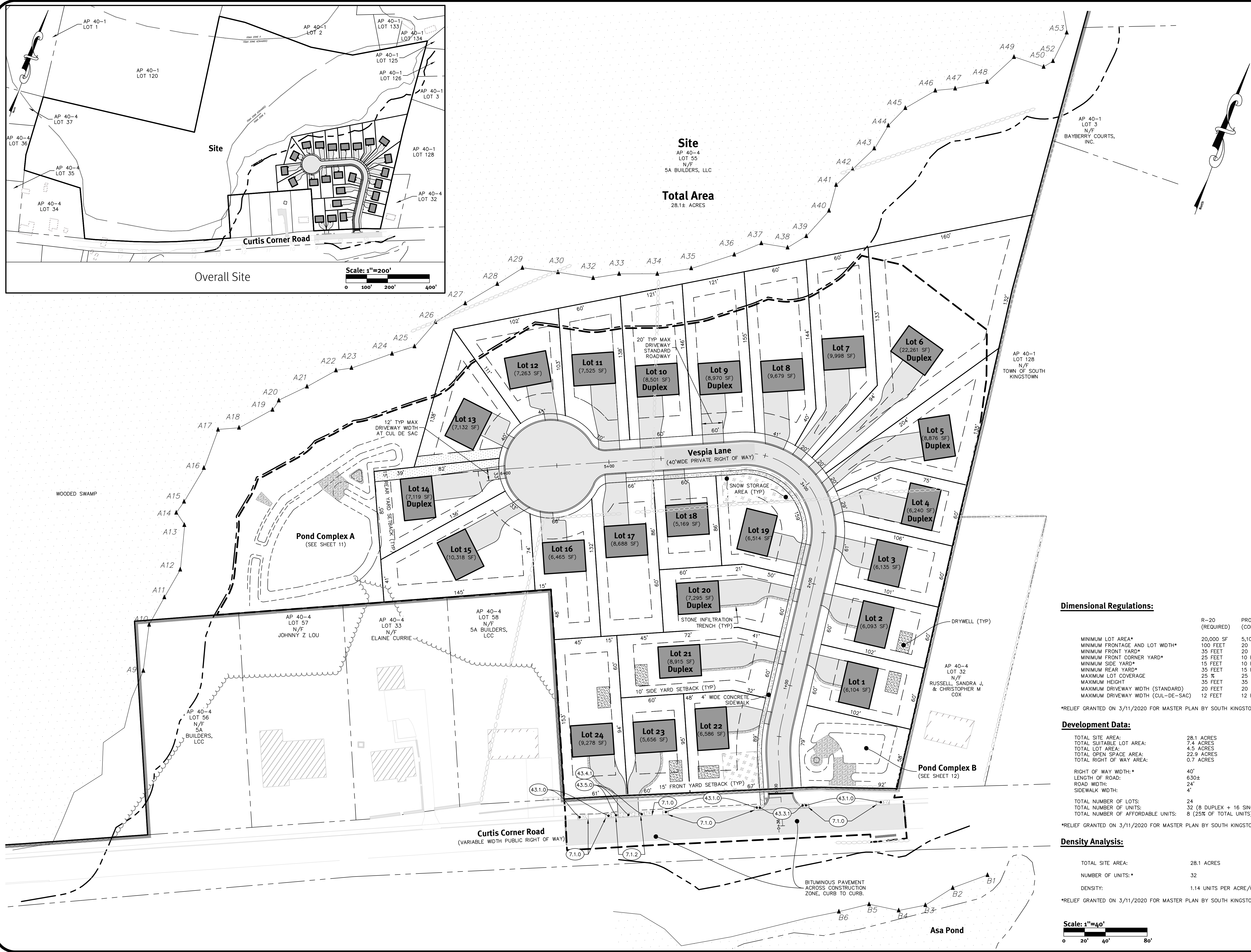

Site
 AP 40-4
 LOT 55
 N/F
 5A BUILDERS, LLC

Total Area
 28.1± ACRES

Dimensional Regulations:

	R-20 (REQUIRED)	PROVIDED (COMPREHENSIVE PERMIT)
MINIMUM LOT AREA*	20,000 SF	5,100 SF
MINIMUM FRONTAGE AND LOT WIDTH*	100 FEET	20 FEET
MINIMUM FRONT YARD*	35 FEET	20 FEET
MINIMUM FRONT CORNER YARD*	25 FEET	10 FEET
MINIMUM SIDE YARD*	15 FEET	10 FEET
MINIMUM REAR YARD*	35 FEET	15 FEET
MAXIMUM LOT COVERAGE	25 %	25 %
MAXIMUM HEIGHT	35 FEET	35 FEET
MAXIMUM DRIVEWAY WIDTH (STANDARD)	20 FEET	20 FEET
MAXIMUM DRIVEWAY WIDTH (CUL-DE-SAC)	12 FEET	12 FEET

Development Data:

TOTAL SITE AREA:	28.1 ACRES
TOTAL SUITABLE LOT AREA:	7.4 ACRES
TOTAL LOT AREA:	4.5 ACRES
TOTAL OPEN SPACE AREA:	22.9 ACRES
TOTAL RIGHT OF WAY AREA:	0.7 ACRES
RIGHT OF WAY WIDTH:	40'
LENGTH OF ROAD:	630±
ROAD WIDTH:	24'
SIDEWALK WIDTH:	4'
TOTAL NUMBER OF LOTS:	24
TOTAL NUMBER OF UNITS:	32 (8 DUPLEX + 16 SINGLE-FAMILY)
TOTAL NUMBER OF AFFORDABLE UNITS:	8 (25% OF TOTAL UNITS)

Density Analysis:

TOTAL SITE AREA:	28.1 ACRES
NUMBER OF UNITS:	32
DENSITY:	1.14 UNITS PER ACRE/0.88 ACRES PER UNIT

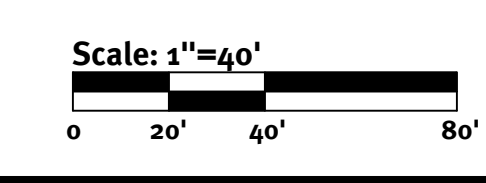

DiPrete Engineering
 Two Stafford Court Cranston, RI 02920
 tel 401-943-1000 fax 401-644-6006 www.diprete-eng.com

Boston • Providence • Newport

KEVIN DEMERS
 REGISTERED PROFESSIONAL ENGINEER
 CIVIL

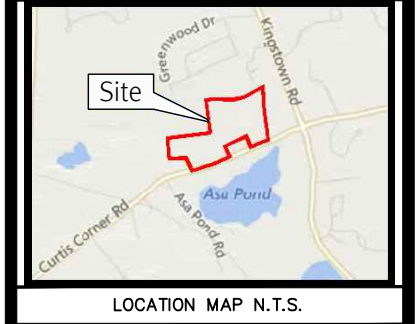

This regulatory submission set shall not be used for construction purposes unless stamped, issued for construction and signed by a DiPrete Engineering representative.

The contractor is responsible for all of the means, methods, safety precautions and requirements, and OSHA conformance in the implementation of this plan and design.

NO.	DATE	DESCRIPTION	DESIGN BY
1	10/28/2020	PRELIMINARY REVISIONS	CHD
2	01/06/2021	PRELIMINARY REVISIONS	CHD
3	07/29/2020	PRELIMINARY REVISIONS	CHD
4	07/29/2020	DATE	BY

Drawn By: L.M.F. Design By: C.H.D.

Site Layout Plan
The Village at Curtis Corner
 Assessor's Plat 40-4, Block 55
 South Kingstown, Rhode Island

Applicant/Owner:
5A Builders, LLC
 220 Knowlesway Extension
 Narragansett, RI 02882

DE JOB NO: 0265-003 Copyright 2017 by DiPrete Engineering Associates, Inc.

z:\megan\projects\0265-003\curtis corner road 109\autocad drawings\0265-003 plan.dwg Plotter: 10/29/2020

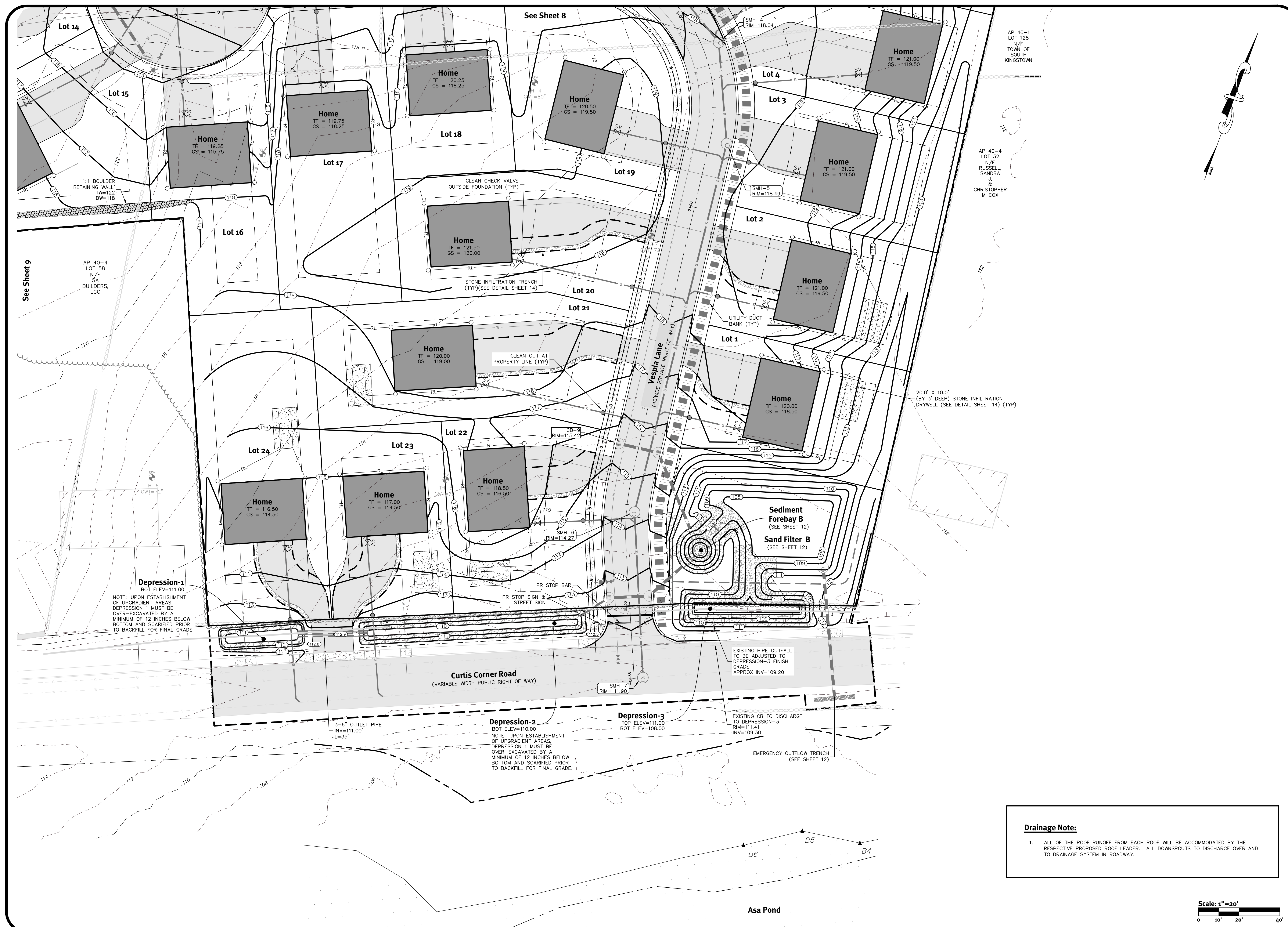

DiPrete Engineering
 Two Stafford Court Cranston, RI 02920
 tel 401-943-1000 fax 401-641-6006 www.diprete-eng.com

Boston • Providence • Newport

KEVIN DEMERS
 REGISTERED PROFESSIONAL ENGINEER
 CIVIL

LOCATION MAP N.T.S.

This regulatory submission set shall not be used for construction purposes unless stamped 'Issued for Construction' and signed by a DiPrete Engineering representative.

The contractor is responsible for all of the means, methods, safety precautions and requirements, and OSHA conformance in the implementation of this plan and design.

NO.	DATE	DESCRIPTION	BY
1	10/29/2020	Preliminary Submissions	JDF
2	10/29/2020	Preliminary Submissions	JDF
3	10/29/2020	Preliminary Submissions	JDF
4	10/29/2020	Preliminary Submissions	JDF
5	10/29/2020	Preliminary Submissions	JDF
6	10/29/2020	Preliminary Submissions	JDF
7	10/29/2020	Preliminary Submissions	JDF
8	10/29/2020	Preliminary Submissions	JDF
9	10/29/2020	Preliminary Submissions	JDF
10	10/29/2020	Preliminary Submissions	JDF
11	10/29/2020	Preliminary Submissions	JDF
12	10/29/2020	Preliminary Submissions	JDF
13	10/29/2020	Preliminary Submissions	JDF
14	10/29/2020	Preliminary Submissions	JDF
15	10/29/2020	Preliminary Submissions	JDF
16	10/29/2020	Preliminary Submissions	JDF
17	10/29/2020	Preliminary Submissions	JDF
18	10/29/2020	Preliminary Submissions	JDF
19	10/29/2020	Preliminary Submissions	JDF
20	10/29/2020	Preliminary Submissions	JDF
21	10/29/2020	Preliminary Submissions	JDF
22	10/29/2020	Preliminary Submissions	JDF
23	10/29/2020	Preliminary Submissions	JDF
24	10/29/2020	Preliminary Submissions	JDF
25	10/29/2020	Preliminary Submissions	JDF
26	10/29/2020	Preliminary Submissions	JDF
27	10/29/2020	Preliminary Submissions	JDF
28	10/29/2020	Preliminary Submissions	JDF
29	10/29/2020	Preliminary Submissions	JDF
30	10/29/2020	Preliminary Submissions	JDF
31	10/29/2020	Preliminary Submissions	JDF
32	10/29/2020	Preliminary Submissions	JDF
33	10/29/2020	Preliminary Submissions	JDF
34	10/29/2020	Preliminary Submissions	JDF
35	10/29/2020	Preliminary Submissions	JDF
36	10/29/2020	Preliminary Submissions	JDF
37	10/29/2020	Preliminary Submissions	JDF
38	10/29/2020	Preliminary Submissions	JDF
39	10/29/2020	Preliminary Submissions	JDF
40	10/29/2020	Preliminary Submissions	JDF
41	10/29/2020	Preliminary Submissions	JDF
42	10/29/2020	Preliminary Submissions	JDF
43	10/29/2020	Preliminary Submissions	JDF
44	10/29/2020	Preliminary Submissions	JDF
45	10/29/2020	Preliminary Submissions	JDF
46	10/29/2020	Preliminary Submissions	JDF
47	10/29/2020	Preliminary Submissions	JDF
48	10/29/2020	Preliminary Submissions	JDF
49	10/29/2020	Preliminary Submissions	JDF
50	10/29/2020	Preliminary Submissions	JDF
51	10/29/2020	Preliminary Submissions	JDF
52	10/29/2020	Preliminary Submissions	JDF
53	10/29/2020	Preliminary Submissions	JDF
54	10/29/2020	Preliminary Submissions	JDF
55	10/29/2020	Preliminary Submissions	JDF
56	10/29/2020	Preliminary Submissions	JDF
57	10/29/2020	Preliminary Submissions	JDF
58	10/29/2020	Preliminary Submissions	JDF
59	10/29/2020	Preliminary Submissions	JDF
60	10/29/2020	Preliminary Submissions	JDF
61	10/29/2020	Preliminary Submissions	JDF
62	10/29/2020	Preliminary Submissions	JDF
63	10/29/2020	Preliminary Submissions	JDF
64	10/29/2020	Preliminary Submissions	JDF
65	10/29/2020	Preliminary Submissions	JDF
66	10/29/2020	Preliminary Submissions	JDF
67	10/29/2020	Preliminary Submissions	JDF
68	10/29/2020	Preliminary Submissions	JDF
69	10/29/2020	Preliminary Submissions	JDF
70	10/29/2020	Preliminary Submissions	JDF
71	10/29/2020	Preliminary Submissions	JDF
72	10/29/2020	Preliminary Submissions	JDF
73	10/29/2020	Preliminary Submissions	JDF
74	10/29/2020	Preliminary Submissions	JDF
75	10/29/2020	Preliminary Submissions	JDF
76	10/29/2020	Preliminary Submissions	JDF
77	10/29/2020	Preliminary Submissions	JDF
78	10/29/2020	Preliminary Submissions	JDF
79	10/29/2020	Preliminary Submissions	JDF
80	10/29/2020	Preliminary Submissions	JDF
81	10/29/2020	Preliminary Submissions	JDF
82	10/29/2020	Preliminary Submissions	JDF
83	10/29/2020	Preliminary Submissions	JDF
84	10/29/2020	Preliminary Submissions	JDF
85	10/29/2020	Preliminary Submissions	JDF
86	10/29/2020	Preliminary Submissions	JDF
87	10/29/2020	Preliminary Submissions	JDF
88	10/29/2020	Preliminary Submissions	JDF
89	10/29/2020	Preliminary Submissions	JDF
90	10/29/2020	Preliminary Submissions	JDF
91	10/29/2020	Preliminary Submissions	JDF
92	10/29/2020	Preliminary Submissions	JDF
93	10/29/2020	Preliminary Submissions	JDF
94	10/29/2020	Preliminary Submissions	JDF
95	10/29/2020	Preliminary Submissions	JDF
96	10/29/2020	Preliminary Submissions	JDF
97	10/29/2020	Preliminary Submissions	JDF
98	10/29/2020	Preliminary Submissions	JDF
99	10/29/2020	Preliminary Submissions	JDF
100	10/29/2020	Preliminary Submissions	JDF

Grading Plan - 1

The Village at Curtis Corner

Asessor: Plat 40-4, South Kingstown, Rhode Island
 Applicant: Curtis Corner
SA Builders, LLC
 Narragansett, RI 02882

DE Job No: 0265-053 Copyright: 2017 by DiPrete Engineering Associates, Inc.

Scale: 1"=20'

Drainage Note:

- ALL OF THE ROOF RUNOFF FROM EACH ROOF WILL BE ACCOMMODATED BY THE RESPECTIVE PROPOSED ROOF LEADER. ALL DOWNSPOUTS TO DISCHARGE OVERLAND TO DRAINAGE SYSTEM IN ROADWAY.

See Sheet 8

See Sheet 9

See Sheet 10

See Sheet 11

See Sheet 12

See Sheet 13

See Sheet 14

See Sheet 15

See Sheet 16

See Sheet 17

See Sheet 18

See Sheet 19

See Sheet 20

See Sheet 21

See Sheet 22

See Sheet 23

See Sheet 24

See Sheet 25

See Sheet 26

See Sheet 27

See Sheet 28

See Sheet 29

See Sheet 30

See Sheet 31

See Sheet 32

See Sheet 33

See Sheet 34

See Sheet 35

See Sheet 36

See Sheet 37

See Sheet 38

See Sheet 39

See Sheet 40

See Sheet 41

See Sheet 42

See Sheet 43

See Sheet 44

See Sheet 45

See Sheet 46

See Sheet 47

See Sheet 48

See Sheet 49

See Sheet 50

See Sheet 51

See Sheet 52

See Sheet 53

See Sheet 54

See Sheet 55

See Sheet 56

See Sheet 57

See Sheet 58

See Sheet 59

See Sheet 60

See Sheet 61

See Sheet 62

See Sheet 63

See Sheet 64

See Sheet 65

See Sheet 66

See Sheet 67

See Sheet 68

See Sheet 69

See Sheet 70

See Sheet 71

See Sheet 72

See Sheet 73

See Sheet 74

See Sheet 75

See Sheet 76

See Sheet 77

See Sheet 78

See Sheet 79

See Sheet 80

See Sheet 81

See Sheet 82

See Sheet 83

See Sheet 84

See Sheet 85

See Sheet 86

See Sheet 87

See Sheet 88

See Sheet 89

See Sheet 90

See Sheet 91

See Sheet 92

See Sheet 93

See Sheet 94

See Sheet 95

See Sheet 96

See Sheet 97

See Sheet 98

See Sheet 99

See Sheet 100

Z:\Main\projects\0265-053\curtis corner road\100\autocad drawings\0265-053-plan.dwg DiPrete: 10/29/2020



Drainage Note:

1. ALL OF THE ROOF RUNOFF FROM EACH ROOF WILL BE ACCOMMODATED BY THE RESPECTIVE PROPOSED ROOF LEADER. ALL DOWNSPOUTS TO DISCHARGE OVERLAND TO DRAINAGE SYSTEM IN ROADWAY.

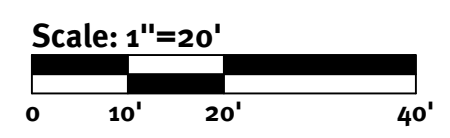

See Sheet 7

DiPrete Engineering
 Two Stafford Court Cranston, RI 02920
 tel 401-943-1000 fax 401-664-6006 www.diprete-eng.com

Boston • Providence • Newport

KEVIN DEMERS
 REGISTERED PROFESSIONAL ENGINEER CIVIL



This regulatory submission set shall not be used for construction purposes unless stamped, issued for construction and signed by a DiPrete Engineering representative.

The contractor is responsible for all of the means, methods, safety precautions and requirements, and OSHA conformance in the implementation of this plan and design.

NO.	DATE	DESCRIPTION	BY	DESIGN BY
1	10/28/2020	Preliminary Revisions	IMF	C.H.D.
2	01/26/2021	Preliminary Revisions	IMF	C.H.D.
3	07/29/2020	Final Plan 100% Wetland Submission	IMF	C.H.D.
4	07/29/2020	Final Plan 100% Wetland Submission	IMF	C.H.D.

Drawn By: IMF, Design By: C.H.D.

Grading Plan - 2
The Village at Curtis Corner
 Accession Plat 40-4, Block 855
 South Kingstown, Rhode Island
 Applicant Owner:
5A Builders, LLC
 220 Knowlesway Extension
 Narragansett, RI 02882

DE Job No: 0265-003 Copyright 2017 by DiPrete Engineering Associates, Inc.

SHEET **8** OF 17

z:\main\projects\0265-003_curtis_corner_road_100\autocad_drawing\0265-003_plan.dwg Plotter: 10/29/2020

Drainage Note:

1. ALL OF THE ROOF RUNOFF FROM EACH ROOF WILL BE ACCOMMODATED BY THE RESPECTIVE PROPOSED ROOF LEADER. ALL DOWNSPOUTS TO DISCHARGE OVERLAND TO DRAINAGE SYSTEM IN ROADWAY.

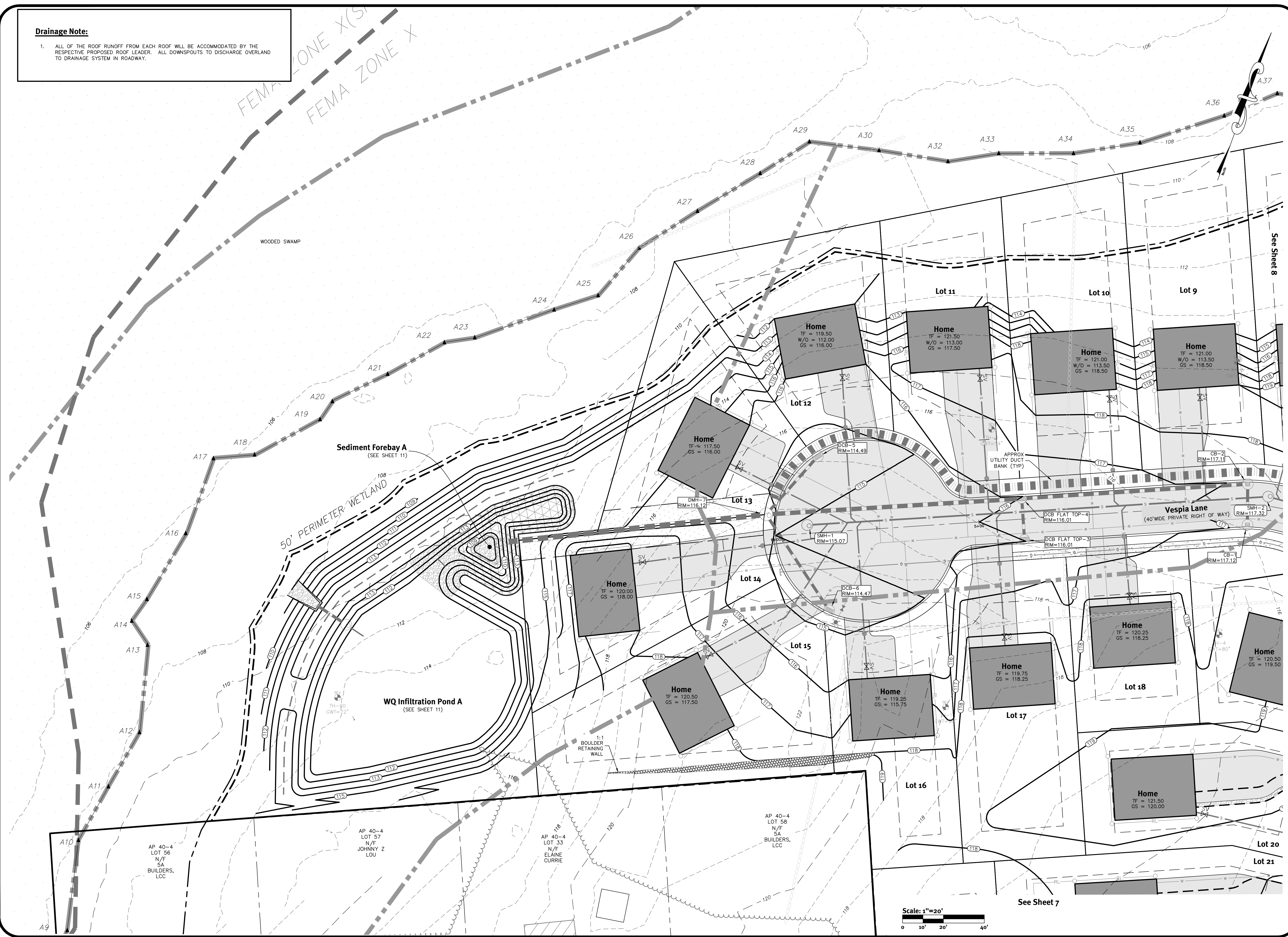

DiPrete Engineering
 Two Stafford Court Cranston, RI 02920
 tel 401-943-1000 fax 401-644-6006 www.diprete-eng.com
Boston • Providence • Newport

KEVIN DEMERS
 REGISTERED PROFESSIONAL ENGINEER CIVIL
 No. 0557
 Site

LOCATION MAP N.T.S.
 This regulatory submission set shall not be used for construction purposes unless stamped 'Issued for Construction' and signed by a DiPrete Engineering representative.
 The contractor is responsible for all of the means, methods, safety precautions and requirements, and OSHA conformance in the implementation of this plan and design.

NO.	DATE	DESCRIPTION	DESIGN BY
1	10/28/2020	Preliminary Revisions	C.H.D.
2	10/28/2020	Preliminary Revisions	J.P.F.
3	11/02/2020	Final Plan (REVISED) Wetlands Submission	J.P.F.
4	11/02/2020	Final Plan (REVISED) Wetlands Submission	J.P.F.
5	11/02/2020	Final Plan (REVISED) Wetlands Submission	J.P.F.
6	11/02/2020	Final Plan (REVISED) Wetlands Submission	J.P.F.
7	11/02/2020	Final Plan (REVISED) Wetlands Submission	J.P.F.
8	11/02/2020	Final Plan (REVISED) Wetlands Submission	J.P.F.
9	11/02/2020	Final Plan (REVISED) Wetlands Submission	J.P.F.
10	11/02/2020	Final Plan (REVISED) Wetlands Submission	J.P.F.
11	11/02/2020	Final Plan (REVISED) Wetlands Submission	J.P.F.
12	11/02/2020	Final Plan (REVISED) Wetlands Submission	J.P.F.
13	11/02/2020	Final Plan (REVISED) Wetlands Submission	J.P.F.
14	11/02/2020	Final Plan (REVISED) Wetlands Submission	J.P.F.
15	11/02/2020	Final Plan (REVISED) Wetlands Submission	J.P.F.
16	11/02/2020	Final Plan (REVISED) Wetlands Submission	J.P.F.
17	11/02/2020	Final Plan (REVISED) Wetlands Submission	J.P.F.
18	11/02/2020	Final Plan (REVISED) Wetlands Submission	J.P.F.
19	11/02/2020	Final Plan (REVISED) Wetlands Submission	J.P.F.
20	11/02/2020	Final Plan (REVISED) Wetlands Submission	J.P.F.
21	11/02/2020	Final Plan (REVISED) Wetlands Submission	J.P.F.
22	11/02/2020	Final Plan (REVISED) Wetlands Submission	J.P.F.
23	11/02/2020	Final Plan (REVISED) Wetlands Submission	J.P.F.
24	11/02/2020	Final Plan (REVISED) Wetlands Submission	J.P.F.
25	11/02/2020	Final Plan (REVISED) Wetlands Submission	J.P.F.
26	11/02/2020	Final Plan (REVISED) Wetlands Submission	J.P.F.
27	11/02/2020	Final Plan (REVISED) Wetlands Submission	J.P.F.
28	11/02/2020	Final Plan (REVISED) Wetlands Submission	J.P.F.
29	11/02/2020	Final Plan (REVISED) Wetlands Submission	J.P.F.
30	11/02/2020	Final Plan (REVISED) Wetlands Submission	J.P.F.
31	11/02/2020	Final Plan (REVISED) Wetlands Submission	J.P.F.
32	11/02/2020	Final Plan (REVISED) Wetlands Submission	J.P.F.
33	11/02/2020	Final Plan (REVISED) Wetlands Submission	J.P.F.
34	11/02/2020	Final Plan (REVISED) Wetlands Submission	J.P.F.
35	11/02/2020	Final Plan (REVISED) Wetlands Submission	J.P.F.
36	11/02/2020	Final Plan (REVISED) Wetlands Submission	J.P.F.
37	11/02/2020	Final Plan (REVISED) Wetlands Submission	J.P.F.
38	11/02/2020	Final Plan (REVISED) Wetlands Submission	J.P.F.
39	11/02/2020	Final Plan (REVISED) Wetlands Submission	J.P.F.
40	11/02/2020	Final Plan (REVISED) Wetlands Submission	J.P.F.
41	11/02/2020	Final Plan (REVISED) Wetlands Submission	J.P.F.
42	11/02/2020	Final Plan (REVISED) Wetlands Submission	J.P.F.
43	11/02/2020	Final Plan (REVISED) Wetlands Submission	J.P.F.
44	11/02/2020	Final Plan (REVISED) Wetlands Submission	J.P.F.
45	11/02/2020	Final Plan (REVISED) Wetlands Submission	J.P.F.
46	11/02/2020	Final Plan (REVISED) Wetlands Submission	J.P.F.
47	11/02/2020	Final Plan (REVISED) Wetlands Submission	J.P.F.
48	11/02/2020	Final Plan (REVISED) Wetlands Submission	J.P.F.
49	11/02/2020	Final Plan (REVISED) Wetlands Submission	J.P.F.
50	11/02/2020	Final Plan (REVISED) Wetlands Submission	J.P.F.

Grading Plan - 3
The Village at Curtis Corner
 Assessor's Plat 40-4, Block 55
 South Kingstown, Rhode Island
 Applicant Owner
SA Builders, LLC
 220 Knowlesway Extension
 Narragansett, RI 02882
 DE Job No: 0265-003 Copyright 2017 by DiPrete Engineering Associates, Inc.
 SHEET 9 OF 17

z:\megan\projects\0265-003\curtis corner road 109\autocad drawings\0265-003 plan.dwg Plotter: 10/29/2020

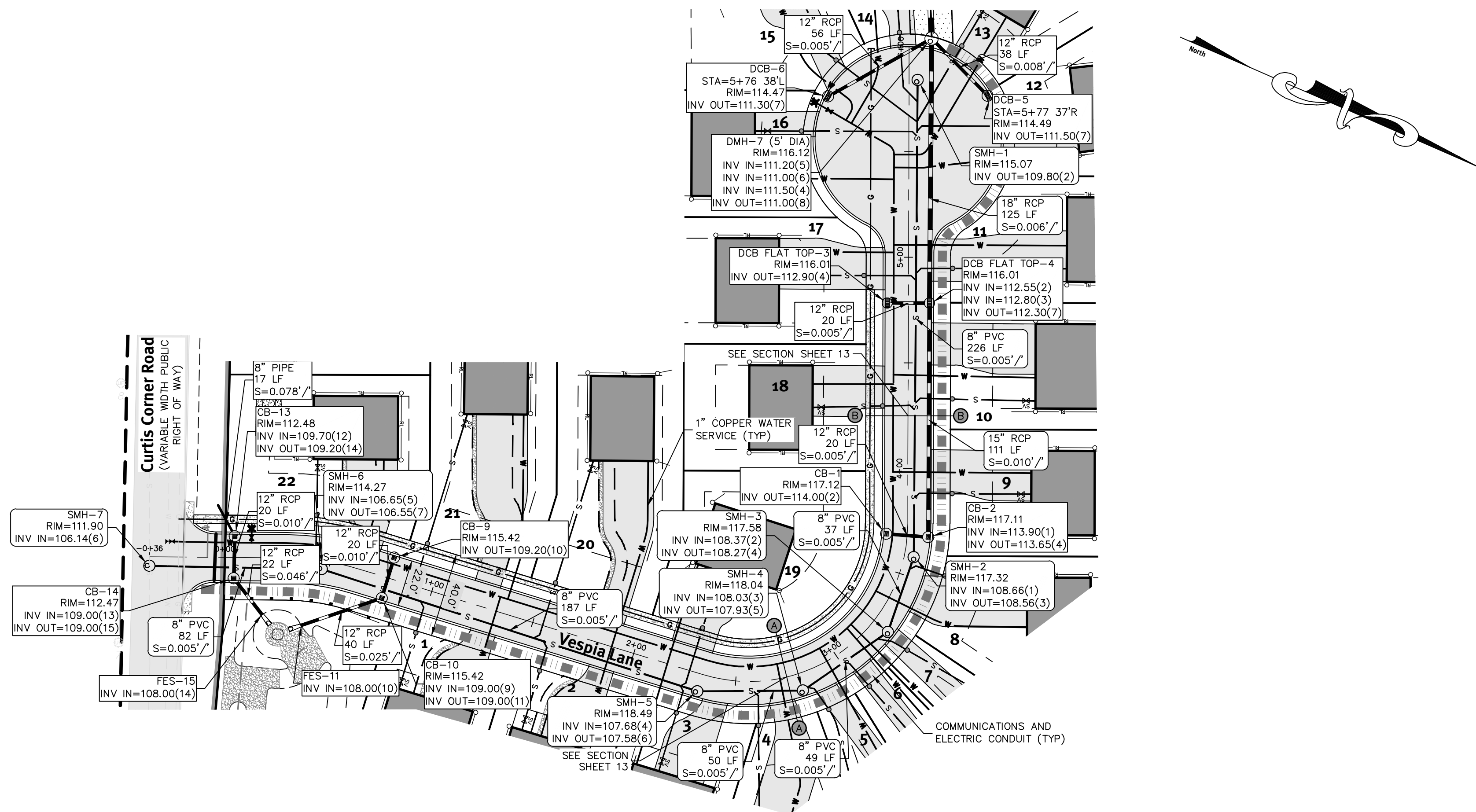

Plan - Vespia Lane

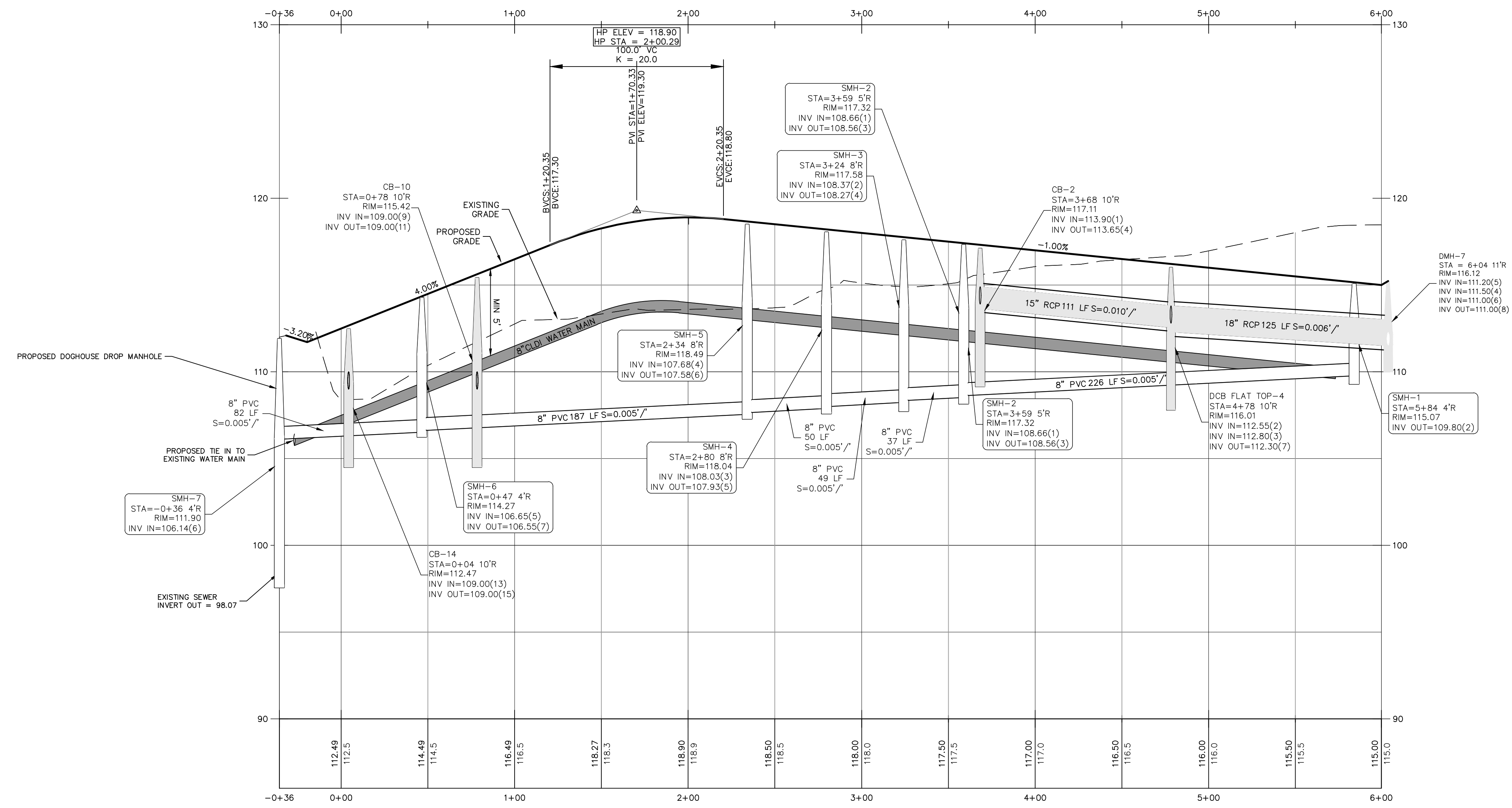

Sta. -0+36 To 6+00
Profile - Vespia Lane

Plan and Profile Notes:

1. ALL SEWER MAIN MUST BE 8" SDR 35 AND LATERALS MUST BE 6" SDR 35.
2. THE (NUMBER) FOLLOWING INVERT IN AND INVERT OUT ELEVATIONS REFER TO THE INVERT IN THE DIRECTION OF THE REFERENCED STRUCTURE.

DiPrete Engineering
 Two Stafford Court Cranston, RI 02920
 Tel: 401-943-1000 Fax: 401-664-6006 www.diprete-eng.com

Boston • Providence • Newport

KEVIN DEMERS
 REGISTERED PROFESSIONAL ENGINEER
 CIVIL

Site
 LOCATION MAP N.T.S.

This regulatory submission set shall not be used for construction purposes unless stamped/issued for Construction and signed by a DiPrete Engineering representative.

The contractor is responsible for all of the means, methods, safety precautions and requirements, and OSHA compliance in the implementation of this plan and design.

NO.	DATE	DESCRIPTION	BY	CHK
2	10/29/2020	Preliminary Revisions		
1	9/22/2020	Preliminary Revisions		
0	7/30/2020	Plain Paper BIM Williams Submission		

Drawn By: J.M.F. Design By: C.H.D.

Plan And Profile
The Village at Curtis Corner
 40-100-005
 South Kingstown, Rhode Island

5A Builders, LLC
 220 Knowledgeway Extension
 Narragansett, RI 02882

DE Job No: 0265-053 Copyright: 2017 by DiPrete Engineering Associates, Inc.

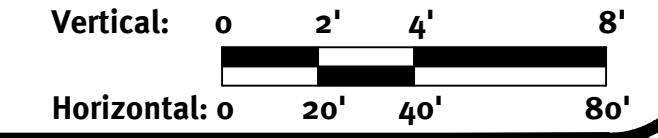

Z:\megan\projects\0265-053 curts corner road\09\uncoord drawings\0265-053-plan.dwg Plot Date: 10/29/2020

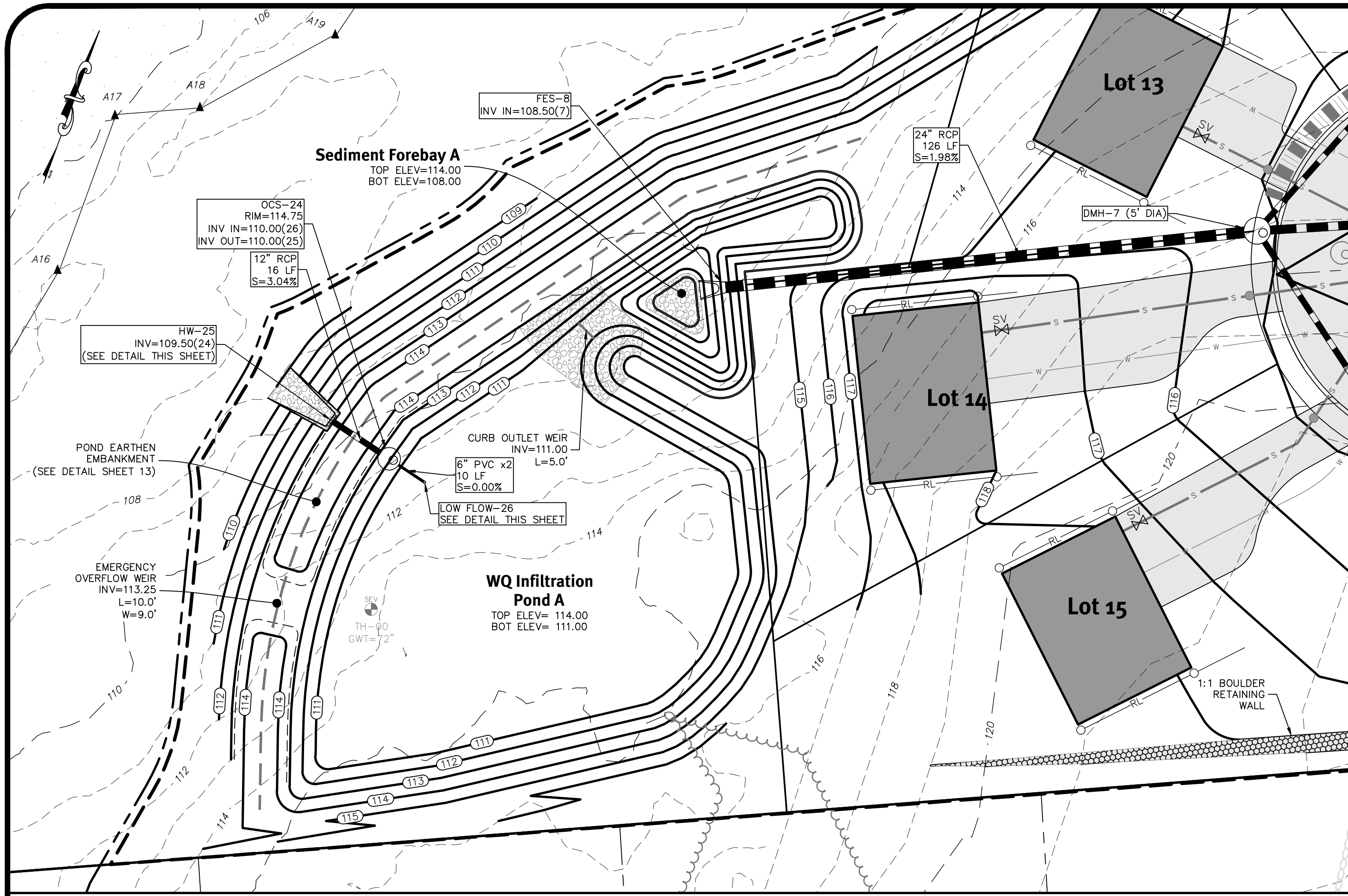

Infiltration Pond A

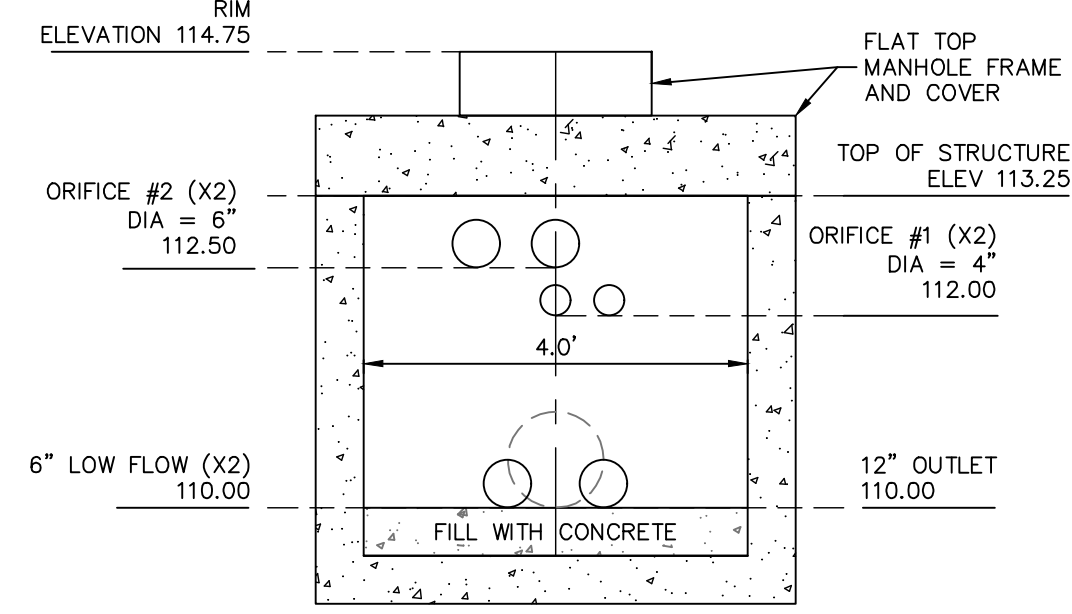
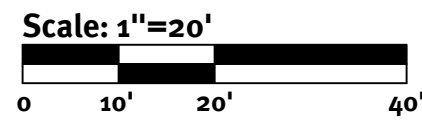

Outlet Control Structure
4' Diameter Manhole (OCS-24)

SCALE: 1"=2'

DESCRIPTION	WQ-A
TOP OF POND ELEVATION	114.00
100 YEAR STORM ELEVATION	113.05
10 YEAR STORM ELEVATION	111.96
1 YEAR STORM ELEVATION	111.21
WQ STORM ELEVATION	111.01
BOTTOM OF POND ELEVATION	111.00
SEASONAL HIGH GWT ELEVATION	108.00
SOIL EVALUATION	TH-00

BOTTOM & SIDE SLOPES OF POND TO BE SEEDED WITH NEW ENGLAND CONTROL/RESTORATION MIX BY NEW ENGLAND WETLAND PLANTS (OR APPROVED EQUAL)

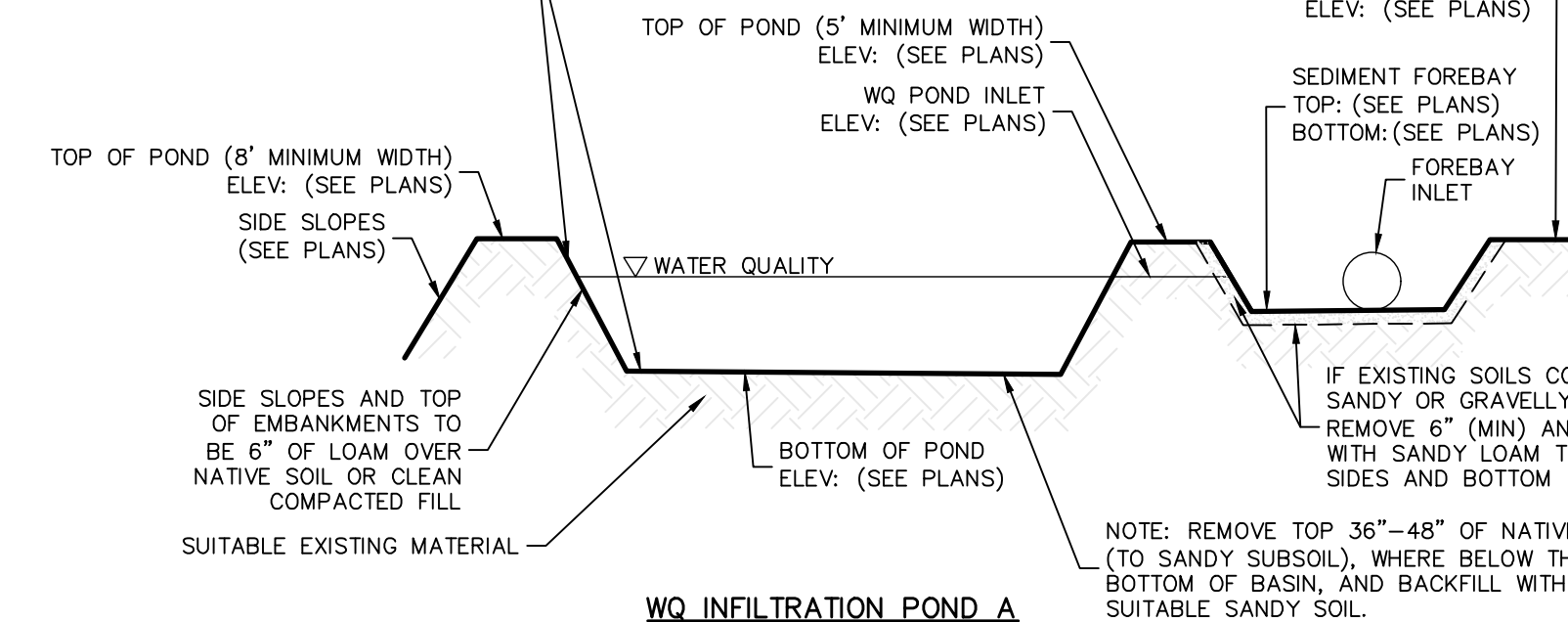

WQ Infiltration Pond A System
NOT TO SCALE

SEDIMENT FOREBAY A
NOT TO SCALE

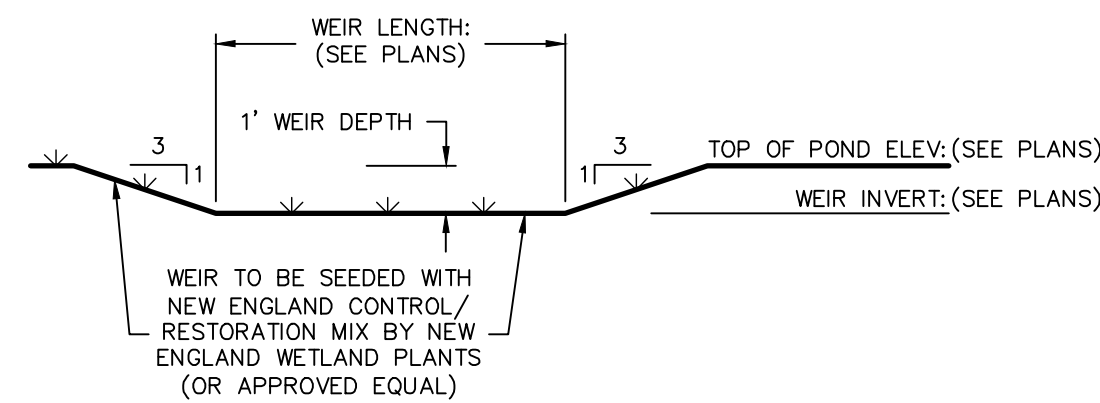

Emergency Overflow Weir
NOT TO SCALE

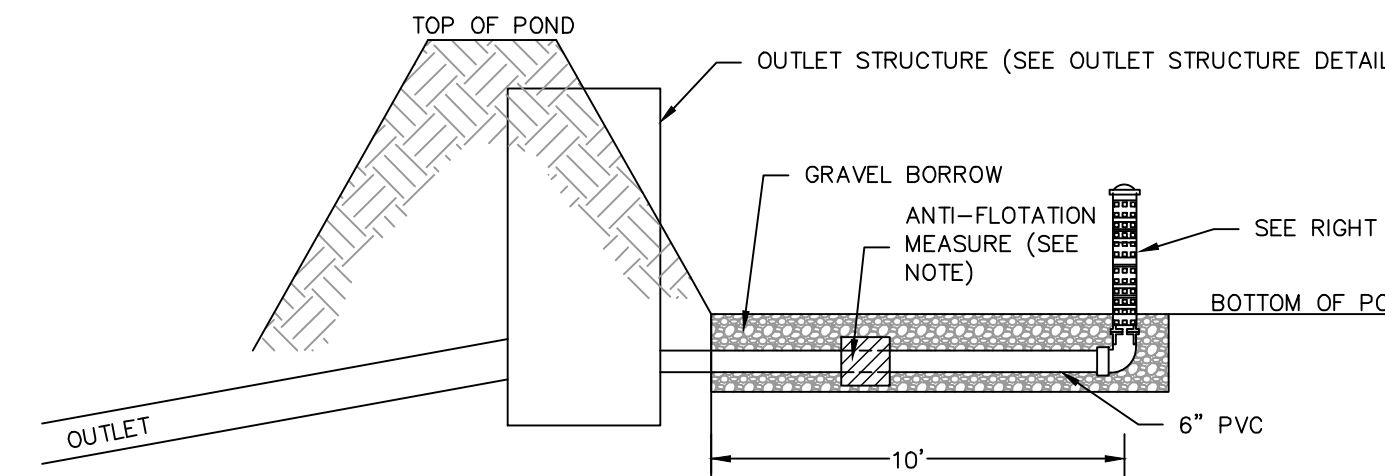

Low Flow Outlet
NOT TO SCALE

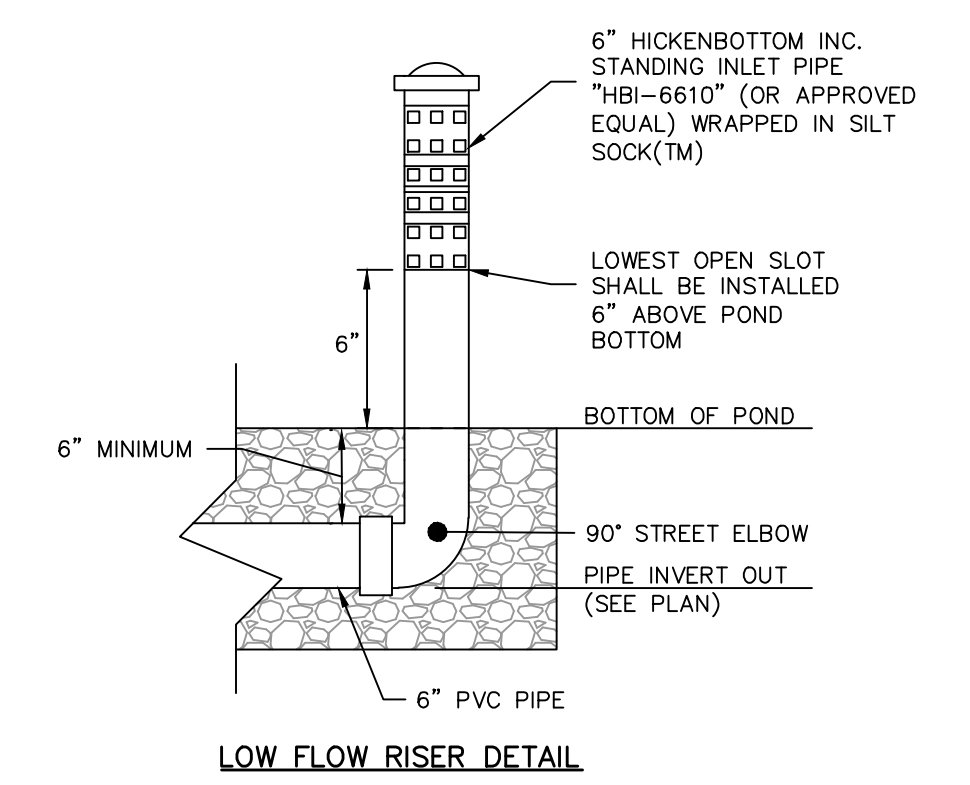

LOW FLOW RISER DETAIL

NOTE: LIMITS OF INFILTRATION POND TO BE STAKED OUT AND NOT USED AS A TEMPORARY SEDIMENT BASIN DURING CONSTRUCTION (NO CONSTRUCTION TRAFFIC ALLOWED WITHIN FILTER LIMITS)

SIDE SLOPES AND TOP OF EMBANKMENTS TO BE 6" OF LOAM OVER NATIVE SOIL OR CLEAN COMPACTED FILL

NOTE: REMOVE TOP 36"-48" OF NATIVE SOIL (TO SANDY SUBSOIL), WHERE BELOW THE BOTTOM OF BASIN, AND BACKFILL WITH SUITABLE SANDY SOIL.

WEIR TO BE SEEDED WITH NEW ENGLAND CONTROL/RESTORATION MIX BY NEW ENGLAND WETLAND PLANTS (OR APPROVED EQUAL)

NOTE: ANTI-FLOTATION TO BE CONCRETE WITH MINIMUM DIMENSIONS OF 13"Wx13"Hx45"L (APPROXIMATELY 6x80LB BAGS OF CONCRETE)

NOTE: 6" HICKENBOTTOM INC. STANDING INLET PIPE "HBI-6610" (OR APPROVED EQUAL) WRAPPED IN SILT SOCK(TM)

HEADWALL	LENGTH	WIDTH	CLASS
HW-25	15.00	9.00	R-3

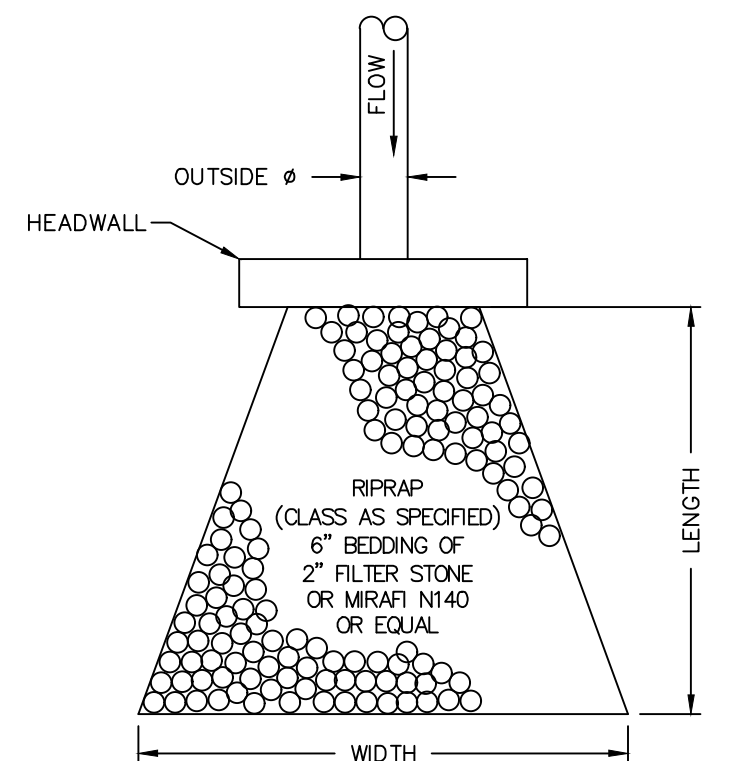

Riprap Apron/Headwall Detail
NOT TO SCALE

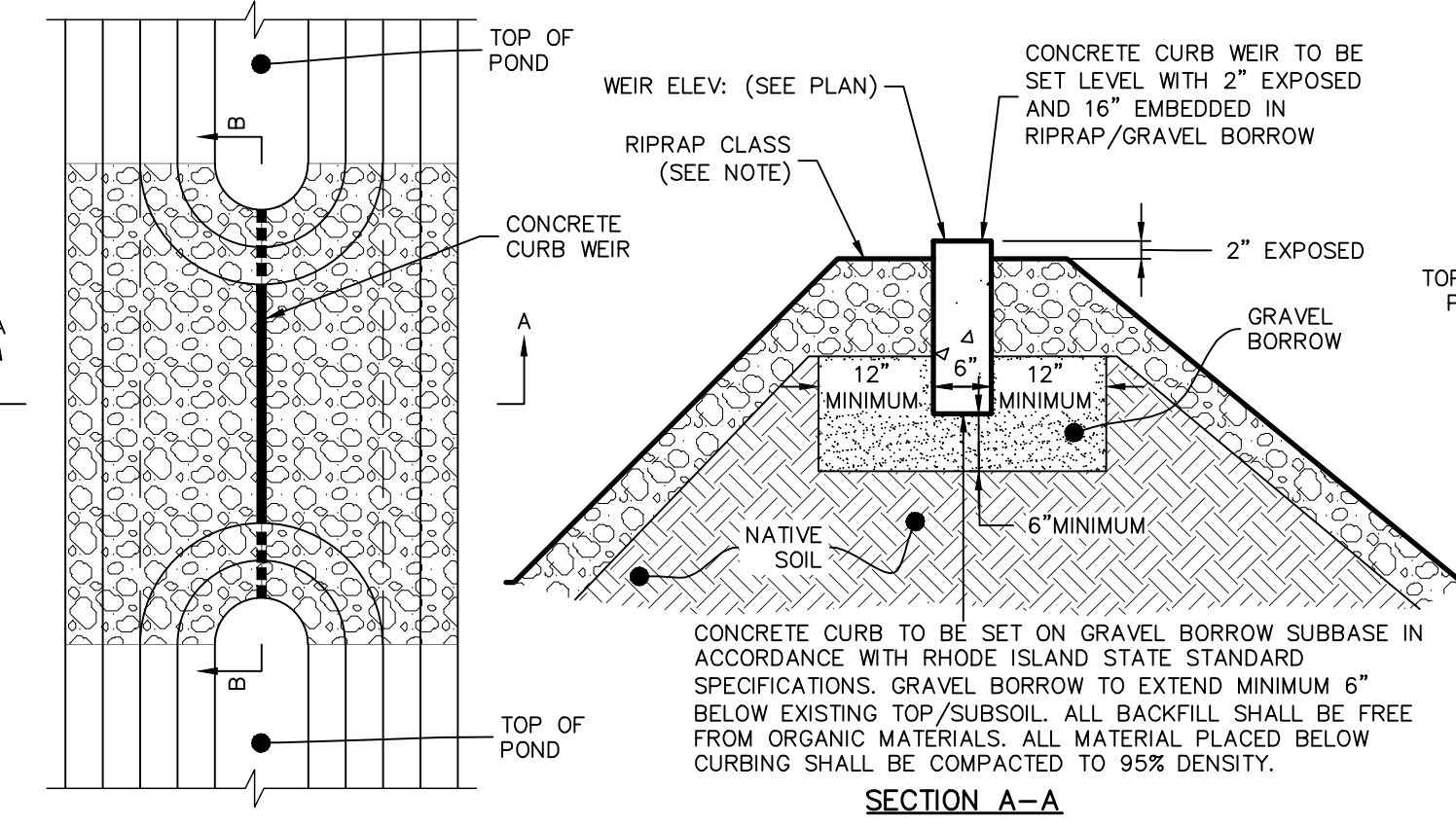

SECTION A-A
NOT TO SCALE

Curb Outlet Weir
NOT TO SCALE

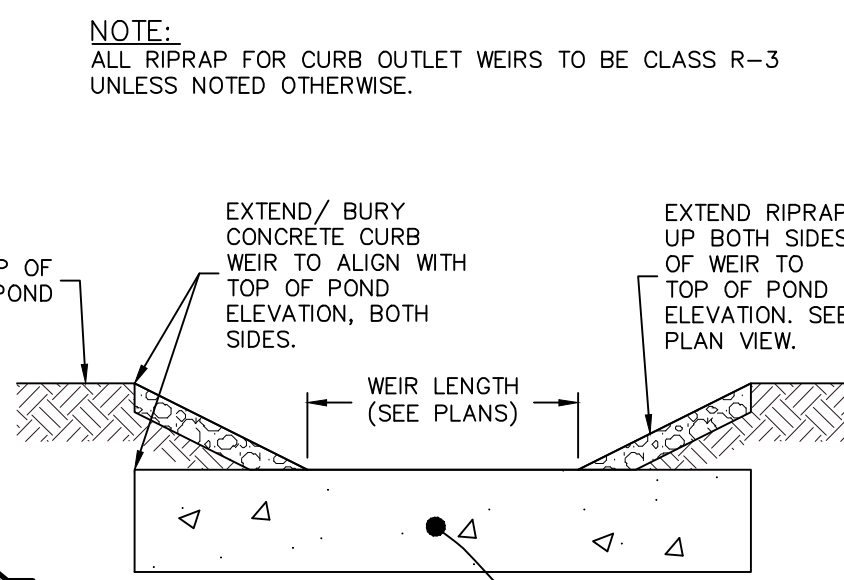

SECTION B-B
NOT TO SCALE

NOTE: ALL CONCRETE CURB WEIRS MUST BE MONOLITHIC. CONCRETE CURB WEIRS CANNOT BE MULTIPLE PRECAST CURBS JOINED IN SEQUENCE.

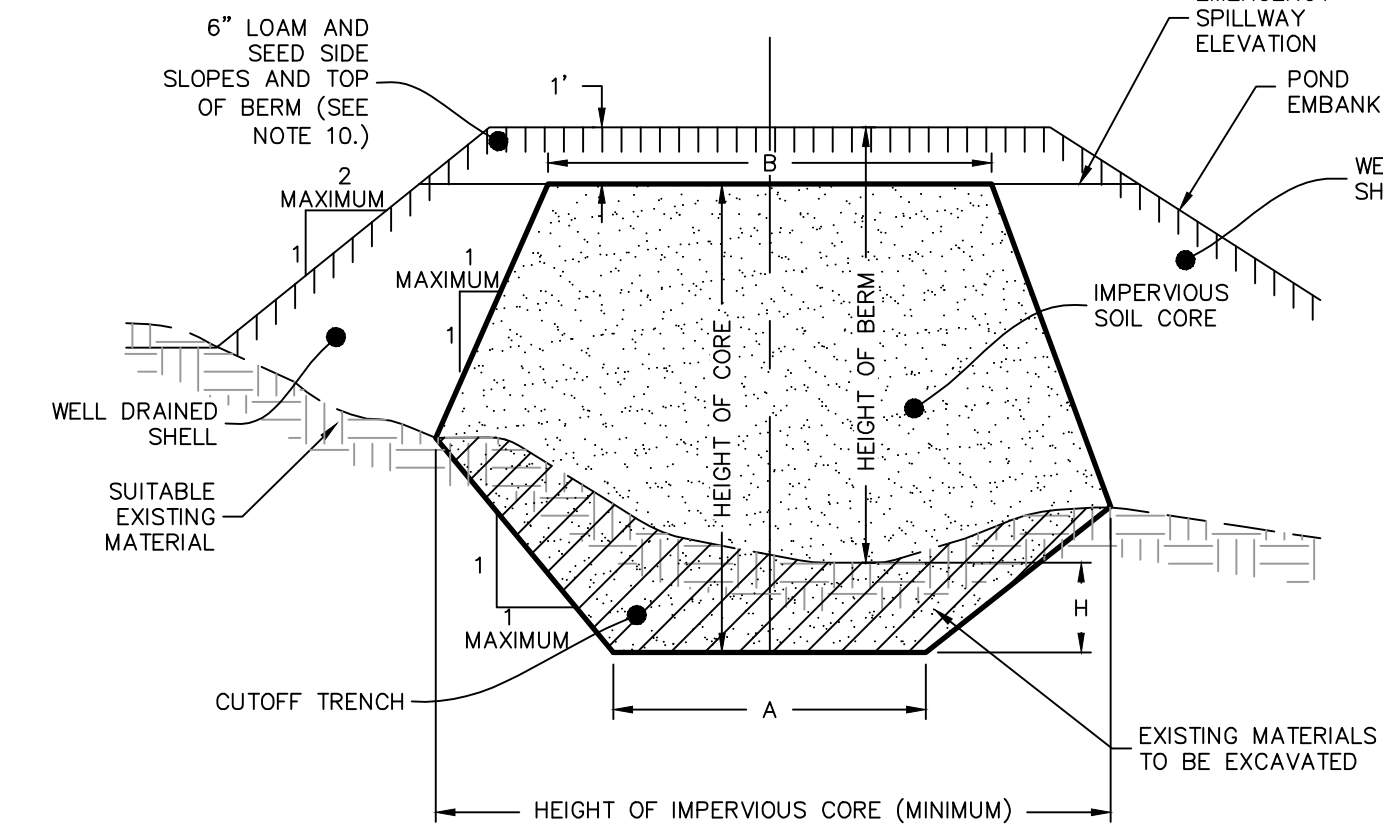

Pond Earthen Embankment
NOT TO SCALE

BERM HEIGHT (FT)	TOP WIDTH OF CORE - B (FT)
0-6.5	8.2
6.6-9.8	9.2
9.9-13.1	9.8
13.2-16.4	10.8
16.5-19.7	11.5

- NOTES:
- IMPERVIOUS SOIL CORE TO BE PROVIDED FOR ALL POND EMBANKMENTS.
 - IMPERVIOUS SOIL CORE TO BE CONSTRUCTED OF A MATERIAL WITH A MINIMUM OF 95% PASSING THE #200 SIEVE AND A MAXIMUM PERMEABILITY OF 0.00005 CM/S.
 - WELL DRAINED SHELL TO BE CONSTRUCTED OF GRAVEL AND/OR SAND WITH LESS THAN 5% PASSING THE #200 SIEVE.
 - MINIMUM DEPTH OF CUTOFF TRENCH (H) SHALL BE 3/4 OF THE TOTAL BERM HEIGHT.
 - THE IMPERVIOUS CORE AT A MINIMUM SHALL EXTEND UP BOTH ABUTMENTS TO THE EMERGENCY SPILLWAY ELEVATION.
 - THE MINIMUM BOTTOM WIDTH (A) SHALL BE 5'-8" AND WIDE ENOUGH TO PERMIT OPERATION OF COMPACTION EQUIPMENT.
 - SIDE SLOPES OF THE TRENCH SHALL BE NO STEEPER THAN 1:1.
 - IF BEDROCK IS ENCOUNTERED BELOW THE DAM THE CUTOFF TRENCH CAN BE REDUCED TO 1'x1' (AxB).
 - COMPACTION REQUIREMENTS FOR THE SHELL AND IMPERVIOUS CORE TO BE 95% OF THE MODIFIED PROCTOR PER ASTM D1557. ALL FILL TO BE PLACED IN LIFTS NOT EXCEEDING 12".
 - SIDE SLOPE OF POND EMBANKMENT TO BE 2:1 MAXIMUM. IF SIDE SLOPES ARE STEEPER THAN 3:1, SLOPE PROTECTION MUST BE UTILIZED ON POND EMBANKMENT. THIS INCLUDES, BUT NOT LIMITED TO, RIPRAP AND EROSION CONTROL MATS.
 - THE IMPERVIOUS CORE SHALL BE KEPT FREE FROM STANDING WATER DURING THE BACKFILL OPERATION.
 - ALL EMBANKMENTS TO BE DESIGNED BY A GEOTECHNICAL ENGINEER PRIOR TO CONSTRUCTION. ALL EMBANKMENT INSTALLATIONS TO BE SUPERVISED BY A GEOTECHNICAL ENGINEER.
 - AN INSPECTION BY THE TOWN IS REQUIRED WHEN THE IMPERVIOUS CORE IS EXCAVATED AND PRIOR TO BEING COVERED.

DiPrete Engineering
Two Stafford Court Cranston, RI 02920
tel 401-943-1000 fax 401-641-6006 www.diprete-eng.com

Boston • Providence • Newport

KEVIN DEMERS
REGISTERED PROFESSIONAL ENGINEER
CIVIL



LOCATION MAP N.T.S.

This regulatory submission set shall not be used for construction purposes unless stamped/issued for Construction and signed by a DiPrete Engineering representative.

The contractor is responsible for all of the means, methods, safety precautions and requirements, and OSHA conformance in the implementation of this plan and design.

NO.	DATE	DESCRIPTION	BY
1	10/29/2020	Preliminary Revisions	JDF
2	10/29/2020	Preliminary Revisions	JDF
3	10/29/2020	Preliminary Revisions	JDF
4	10/29/2020	Preliminary Revisions	JDF
5	10/29/2020	Preliminary Revisions	JDF
6	10/29/2020	Preliminary Revisions	JDF

Drawn By: J.M.F. Design By: C.H.D.

BMP A Details
The Village at Curtis Corner
Assessor's Plot 40-41-42-43-44-45
South Kingston, Rhode Island
Application Owner:
5A Builders, LLC
220 Knowlesway Extension
Narragansett, RI 02882

DE Job No: 0265-053 Copyright 2021 by DiPrete Engineering Associates, Inc.

SHEET **11** OF 17

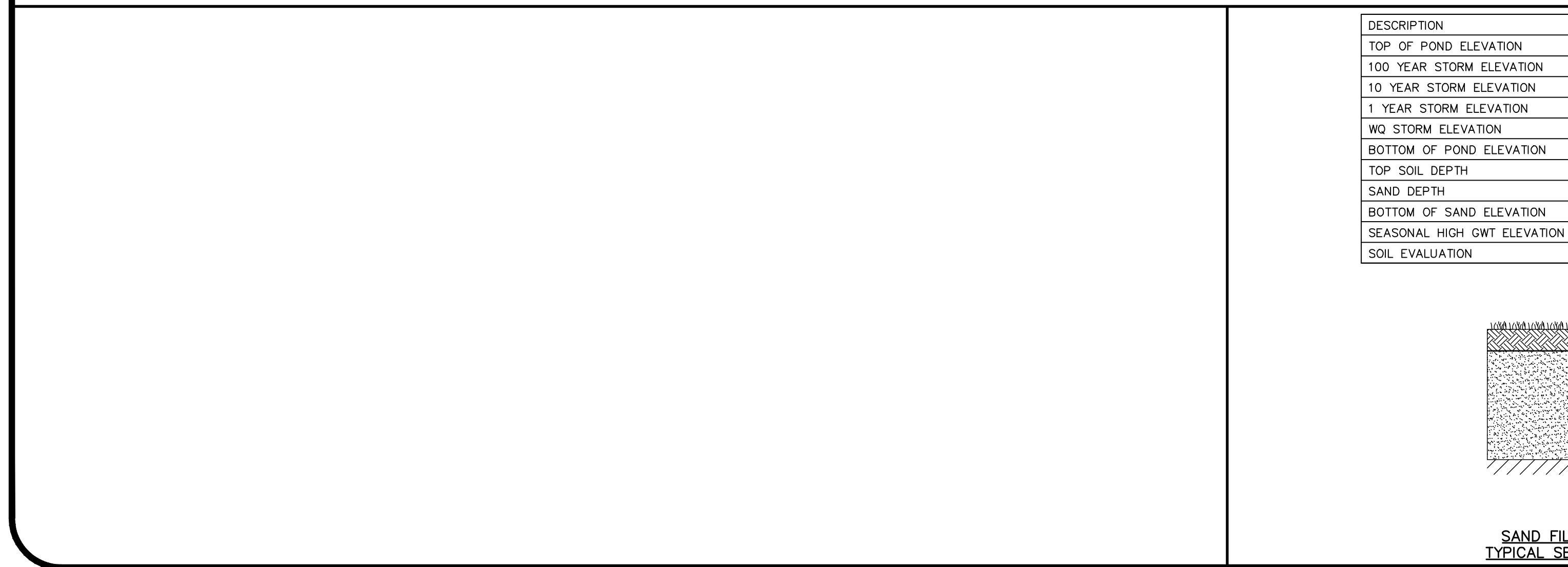
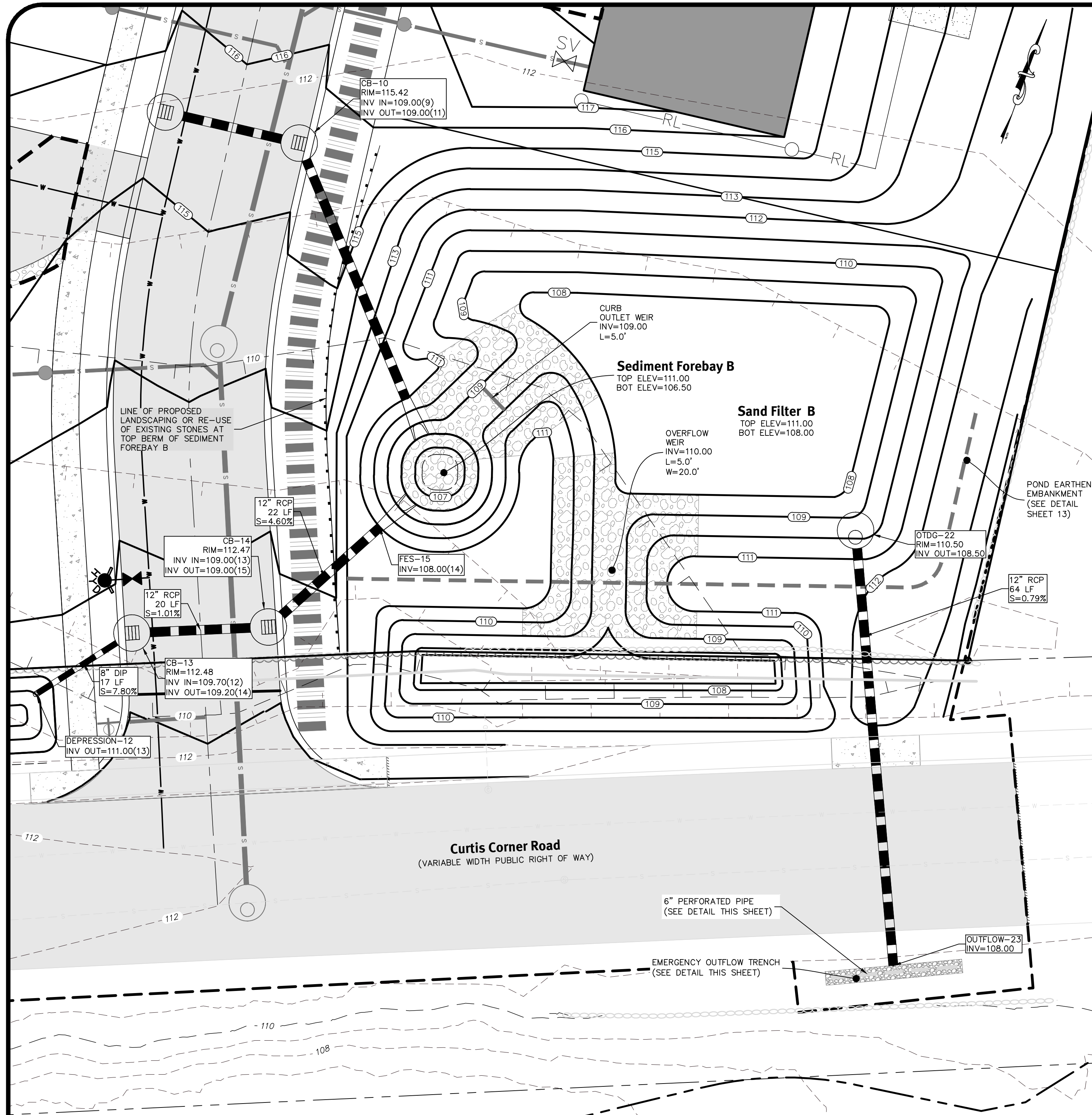

DESCRIPTION	SNDF-B
TOP OF POND ELEVATION	112.00
100 YEAR STORM ELEVATION	111.07
10 YEAR STORM ELEVATION	109.78
1 YEAR STORM ELEVATION	106.26
WQ STORM ELEVATION	106.00
BOTTOM OF POND ELEVATION	108.00
TOP SOIL DEPTH	6"
SAND DEPTH	18"
BOTTOM OF SAND ELEVATION	106.00
SEASONAL HIGH GWT ELEVATION	104.50
SOIL EVALUATION	TH-5

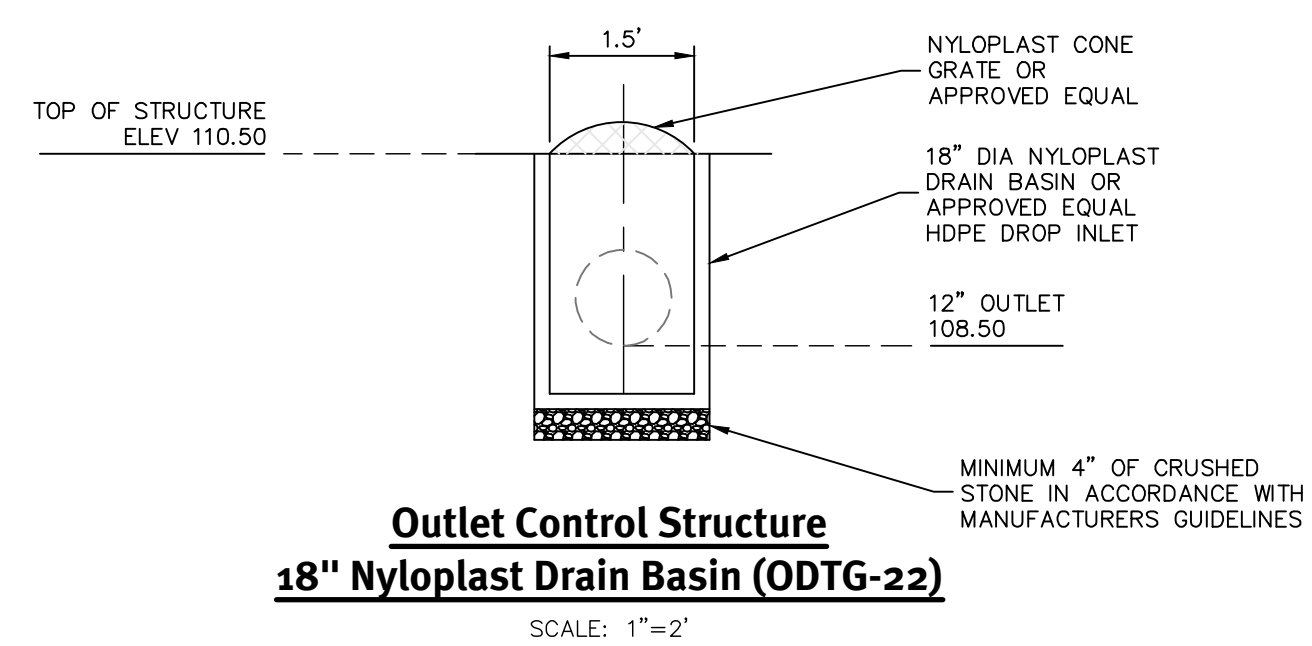
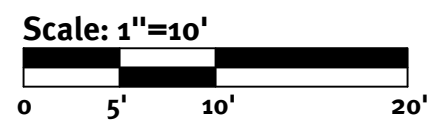

Outlet Control Structure
18" Nyloplast Drain Basin (ODTG-22)
SCALE: 1"=2'

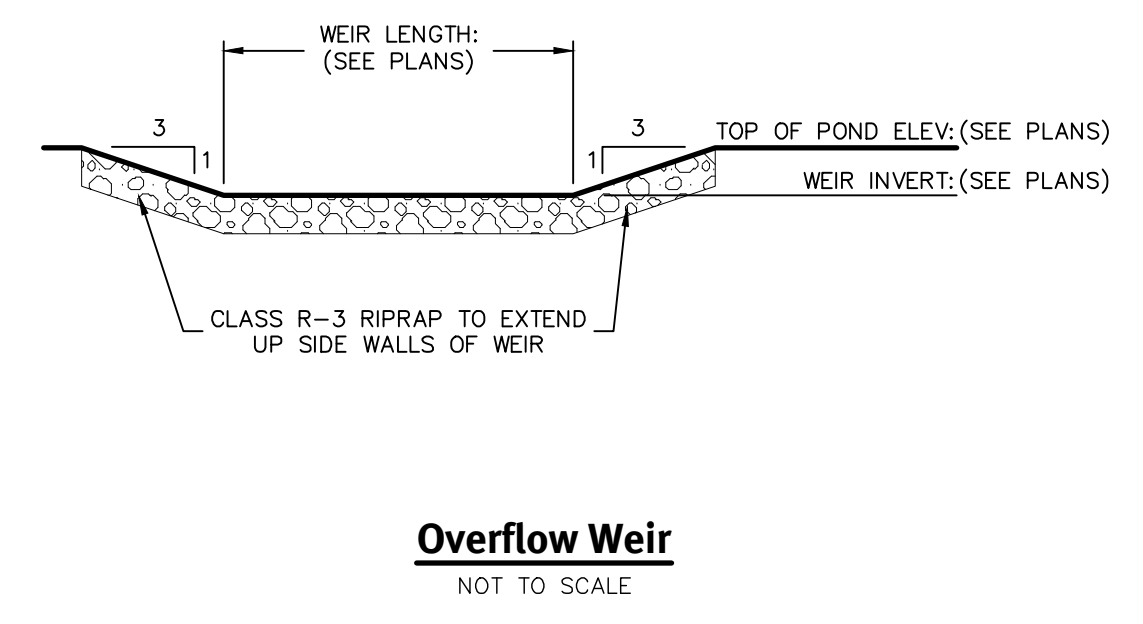

Overflow Weir
NOT TO SCALE

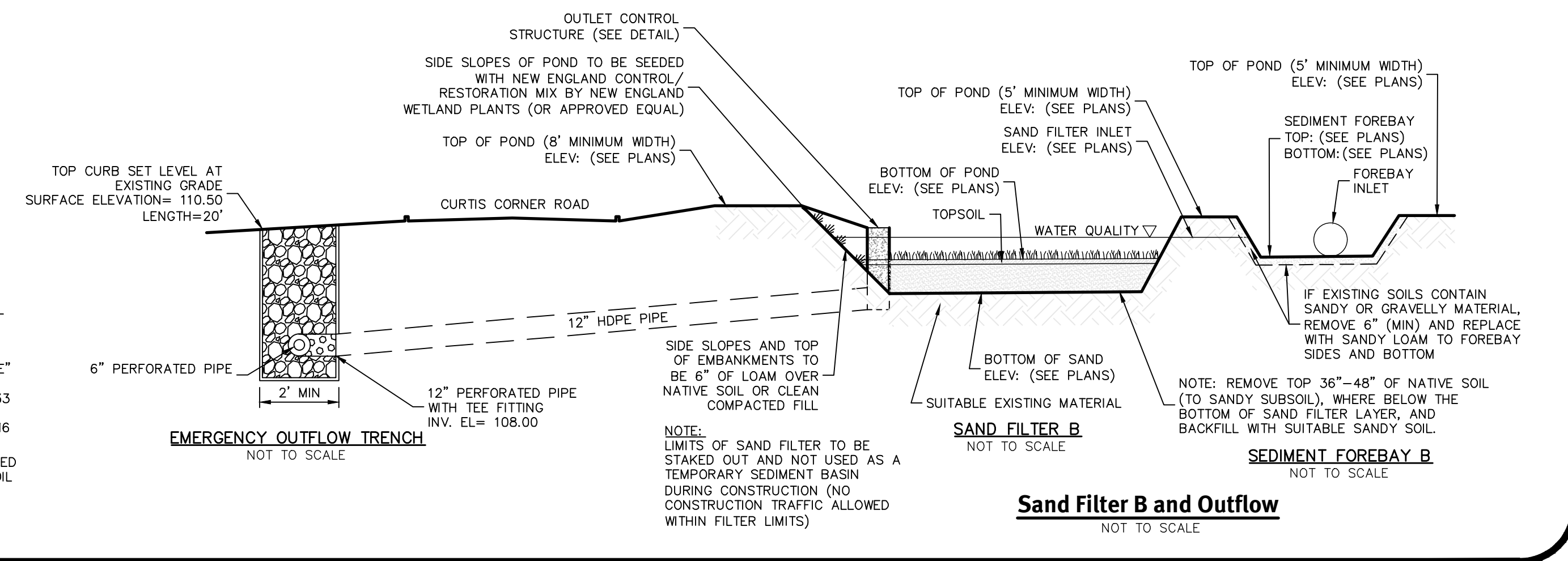

Sand Filter B and Outflow
NOT TO SCALE

DiPrete Engineering
Two Stafford Court Cranston, RI 02920
tel 401-943-1000 fax 401-641-6006 www.diprete-eng.com

Boston • Providence • Newport

KEVIN DEMERS
REGISTERED PROFESSIONAL ENGINEER
CIVIL

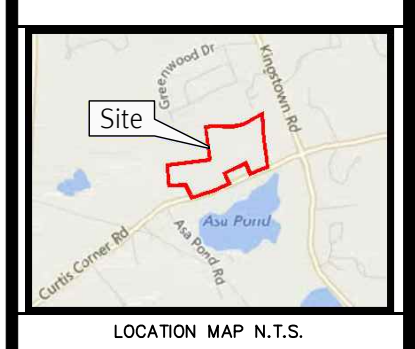

This regulatory submission set shall not be used for construction purposes unless stamped 'Issued for Construction' and signed by a DiPrete Engineering representative.

The contractor is responsible for all of the means, methods, safety precautions and requirements, and OSHA conformance in the implementation of this plan and design.

NO.	DATE	DESCRIPTION	BY
1	2/20/2020	Preliminary Review	JD
2	10/29/2020	Preliminary Review	JD
3	7/30/2020	Preliminary Review	JD
4	7/30/2020	Preliminary Review	JD
5	7/30/2020	Preliminary Review	JD
6	7/30/2020	Preliminary Review	JD

Drawn By: J.M.F. Design By: C.H.D.

BMP Details
The Village at Curtis Corner
40° 40' 00" N
South Kingston, Rhode Island
Application Owner:
5A Builders, LLC
220 Knowlesway Extension
Narragansett, RI 02882

DE Job No: 0265-053 Copyright 2017 by DiPrete Engineering Associates, Inc.

SHEET **12** OF 17

Z:\heman\projects\0265-053\curtis corner road\09\unccad drawings\0265-053-bmps.dwg Plotted: 10/29/2020

GENERAL NOTES:

- ROADWAY CROSS SECTION AND MATERIALS SHALL CONFORM TO TOWN OF SOUTH KINGSTOWN STANDARDS FOR ROAD CONSTRUCTION AND UTILITY LOCATIONS.
- ROADWAY WILL INCLUDE A MONOLITHIC BITUMINOUS BERM, SLOPE FACED PRECAST CONCRETE CURBING REQUIRED AT ALL INTERSECTION FILLET CURVES. SEE RIDOT STD. 7.2.0.
- WATER MAIN LOCATION SUBJECT TO APPROVAL OF THE DIRECTOR OF PUBLIC WORKS.
- STORM DRAIN MATERIALS AND METHODS SHALL CONFORM TO APPLICABLE TOWN OF SOUTH KINGSTOWN AND RIDOT STANDARDS.
- FIRE ALARMS ARE REQUIRED AND SHALL BE INSTALLED ACCORDING TO TOWN FIRE DEPARTMENT REQUIREMENTS.
- UNDERGROUND UTILITY TRENCH CONSTRUCTION TO CONFORM TO THE NATIONAL GRID "DEVELOPER/CONTRACTOR/CUSTOMER RESPONSIBILITIES AND CONSTRUCTION SPECIFICATIONS FOR UNDERGROUND RESIDENTIAL DEVELOPMENTS".
- SEWER MAIN SEPARATION TO WATER MAIN: 10' HORIZONTAL OR 2' VERTICAL BELOW WATER MAIN.

CONSTRUCTION NOTES:

- CLEARING AND GRUBBING: ALL ROOT SYSTEMS, TREES, STUMPS, BUSHES, AND OTHER OBJECTIONABLE MATERIALS SHALL BE REMOVED AND DISPOSED OF AS INDICATED BY THE MUNICIPAL ENGINEER. HEALTHY TREES WITHIN THE RIGHTS-OF-WAY WIDTH AND OUTSIDE THE PAVEMENT WIDTH MAY BE LEFT STANDING, PROVIDED SAID TREES ARE NOT MORE THAN 5' FROM THE RIGHT-OF-WAY LINE, EXCEPT WHERE SIDEWALKS ARE REQUIRED.
- EARTH EXCAVATIONS SHALL INCLUDE, BUT NOT BE LIMITED TO, THE REMOVAL OF CLAY, SAND, GRAVEL, LOAM, SOFT OR DISINTEGRATED ROCK WHICH CAN BE REMOVED WITHOUT BLASTING; BOULDERS OF LESS THAN 1/2 CUBIC YARD IN VOLUME; AND, OTHER UNACCEPTABLE MATERIALS WITHIN THE LIMITS OF ROADWAY, DRAINAGE, OR OTHER EXCAVATION.
- ROCK AND LEDGE EXCAVATION SHALL INCLUDE REMOVAL AND DISPOSAL OF ALL BOULDERS OF 1/2 CUBIC YARD OR MORE IN VOLUME AND ALL HARD LEDGE ROCK WHICH CAN BE REMOVED ONLY BY DRILLING AND SPLITTING MECHANICALLY BY HAND OR BLASTING.
- WHERE GROUND WATER IS ENCOUNTERED WITHIN 5' OF FINISHED GRADE AS DETERMINED BY RI DEPARTMENT OF ENVIRONMENTAL MANAGEMENT, "GROUND WATER PROCEDURES", DURING THE WET SEASON, ADEQUATE SUBSURFACE DRAINAGE SHALL BE CONSTRUCTED TO LOWER THE GROUND WATER LEVEL TO A DEPTH OF AT LEAST 5' BELOW FINISHED GRADE. PAVEMENT SHALL BE CONSTRUCTED SO AS TO PROVIDE A MINIMUM CROSS SECTION AFTER COMPACTION OF 8" GRAVEL BORROW BASE COURSE SUBBASE IN FILL AND 10" GRAVEL BORROW BASE COURSE IN CUTS WITH 2" OF CRUSHED BANK RUN GRAVEL BORROW (MEETING TOWN SPECIFICATIONS) AND HOT-MIX ASPHALTIC AND BITUMINOUS CONCRETE MATERIALS CONFORMING TO R.I. STANDARD SPECIFICATIONS.

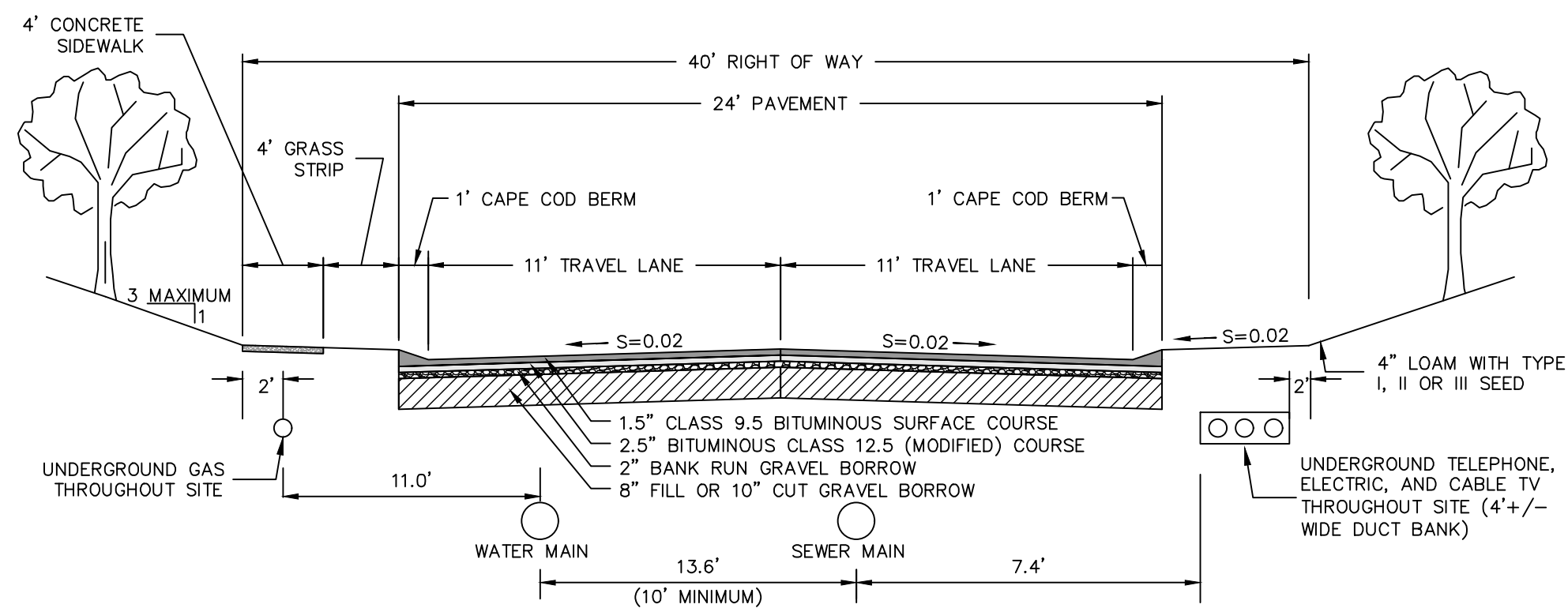
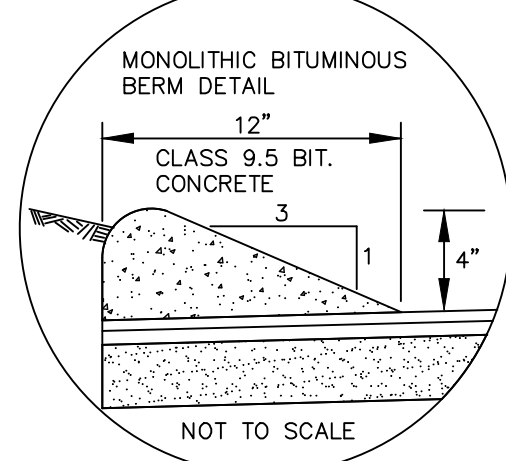

Typical Road Construction (Vespia Lane)
STATION 2+75 (NOT TO SCALE)

GENERAL NOTES:

- ROADWAY CROSS SECTION AND MATERIALS SHALL CONFORM TO TOWN OF SOUTH KINGSTOWN STANDARDS FOR ROAD CONSTRUCTION AND UTILITY LOCATIONS.
- ROADWAY WILL INCLUDE A MONOLITHIC BITUMINOUS BERM, SLOPE FACED PRECAST CONCRETE CURBING REQUIRED AT ALL INTERSECTION FILLET CURVES. SEE RIDOT STD. 7.2.0.
- WATER MAIN LOCATION SUBJECT TO APPROVAL OF THE DIRECTOR OF PUBLIC WORKS.
- STORM DRAIN MATERIALS AND METHODS SHALL CONFORM TO APPLICABLE TOWN OF SOUTH KINGSTOWN AND RIDOT STANDARDS.
- FIRE ALARMS ARE REQUIRED AND SHALL BE INSTALLED ACCORDING TO TOWN FIRE DEPARTMENT REQUIREMENTS.
- UNDERGROUND UTILITY TRENCH CONSTRUCTION TO CONFORM TO THE NATIONAL GRID "DEVELOPER/CONTRACTOR/CUSTOMER RESPONSIBILITIES AND CONSTRUCTION SPECIFICATIONS FOR UNDERGROUND RESIDENTIAL DEVELOPMENTS".
- SEWER MAIN SEPARATION TO WATER MAIN: 10' HORIZONTAL OR 2' VERTICAL BELOW WATER MAIN.

CONSTRUCTION NOTES:

- CLEARING AND GRUBBING: ALL ROOT SYSTEMS, TREES, STUMPS, BUSHES, AND OTHER OBJECTIONABLE MATERIALS SHALL BE REMOVED AND DISPOSED OF AS INDICATED BY THE MUNICIPAL ENGINEER. HEALTHY TREES WITHIN THE RIGHTS-OF-WAY WIDTH AND OUTSIDE THE PAVEMENT WIDTH MAY BE LEFT STANDING, PROVIDED SAID TREES ARE NOT MORE THAN 5' FROM THE RIGHT-OF-WAY LINE, EXCEPT WHERE SIDEWALKS ARE REQUIRED.
- EARTH EXCAVATIONS SHALL INCLUDE, BUT NOT BE LIMITED TO, THE REMOVAL OF CLAY, SAND, GRAVEL, LOAM, SOFT OR DISINTEGRATED ROCK WHICH CAN BE REMOVED WITHOUT BLASTING; BOULDERS OF LESS THAN 1/2 CUBIC YARD IN VOLUME; AND, OTHER UNACCEPTABLE MATERIALS WITHIN THE LIMITS OF ROADWAY, DRAINAGE, OR OTHER EXCAVATION.
- ROCK AND LEDGE EXCAVATION SHALL INCLUDE REMOVAL AND DISPOSAL OF ALL BOULDERS OF 1/2 CUBIC YARD OR MORE IN VOLUME AND ALL HARD LEDGE ROCK WHICH CAN BE REMOVED ONLY BY DRILLING AND SPLITTING MECHANICALLY BY HAND OR BLASTING.
- WHERE GROUND WATER IS ENCOUNTERED WITHIN 5' OF FINISHED GRADE AS DETERMINED BY RI DEPARTMENT OF ENVIRONMENTAL MANAGEMENT, "GROUND WATER PROCEDURES", DURING THE WET SEASON, ADEQUATE SUBSURFACE DRAINAGE SHALL BE CONSTRUCTED TO LOWER THE GROUND WATER LEVEL TO A DEPTH OF AT LEAST 5' BELOW FINISHED GRADE. PAVEMENT SHALL BE CONSTRUCTED SO AS TO PROVIDE A MINIMUM CROSS SECTION AFTER COMPACTION OF 8" GRAVEL BORROW BASE COURSE SUBBASE IN FILL AND 10" GRAVEL BORROW BASE COURSE IN CUTS WITH 2" OF CRUSHED BANK RUN GRAVEL BORROW (MEETING TOWN SPECIFICATIONS) AND HOT-MIX ASPHALTIC AND BITUMINOUS CONCRETE MATERIALS CONFORMING TO R.I. STANDARD SPECIFICATIONS.

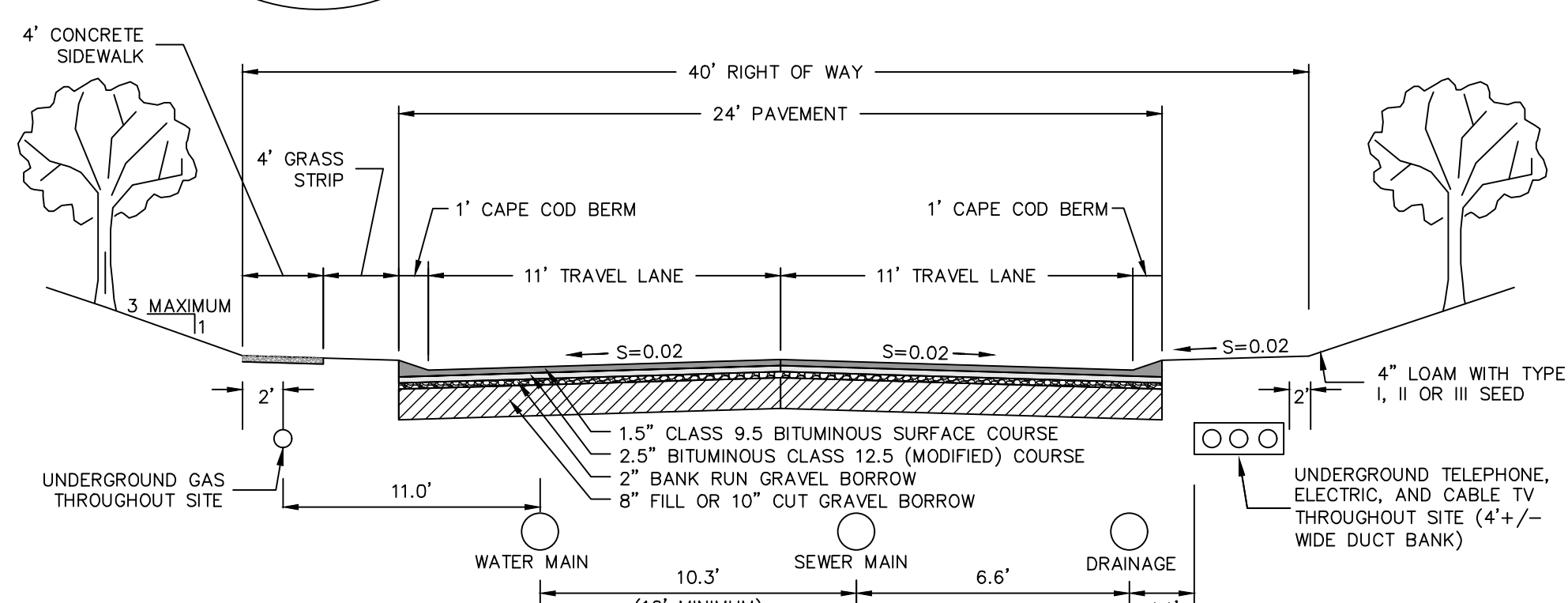
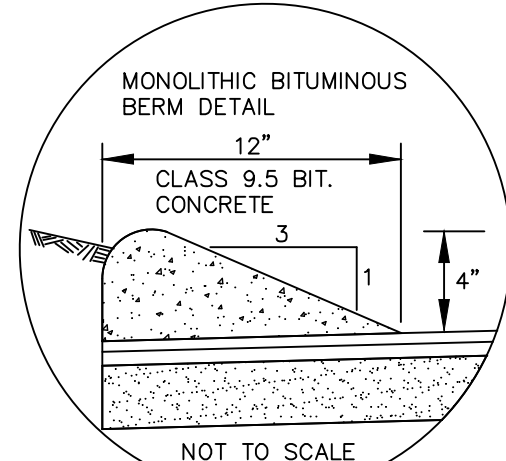

Typical Road Construction (Vespia Lane)
STATION 4+25 (NOT TO SCALE)

NOTES:

- FOOTING TO BE COMPACTED TO 95% AND SLOPED TOWARDS EMBANKMENT OR LAID LEVEL.
- REMOVE AND DISPOSE TOP AND SUB SOIL.
- PLACE ON NATURE ORGANIC FREE SURFACE.
- RETAINING WALLS GREATER THAN 5' HIGH TO BE DESIGNED BY A RI PROFESSIONAL ENGINEER. SHOP DRAWINGS SHALL BE PROVIDED TO SITE ENGINEER PRIOR TO CONSTRUCTION.

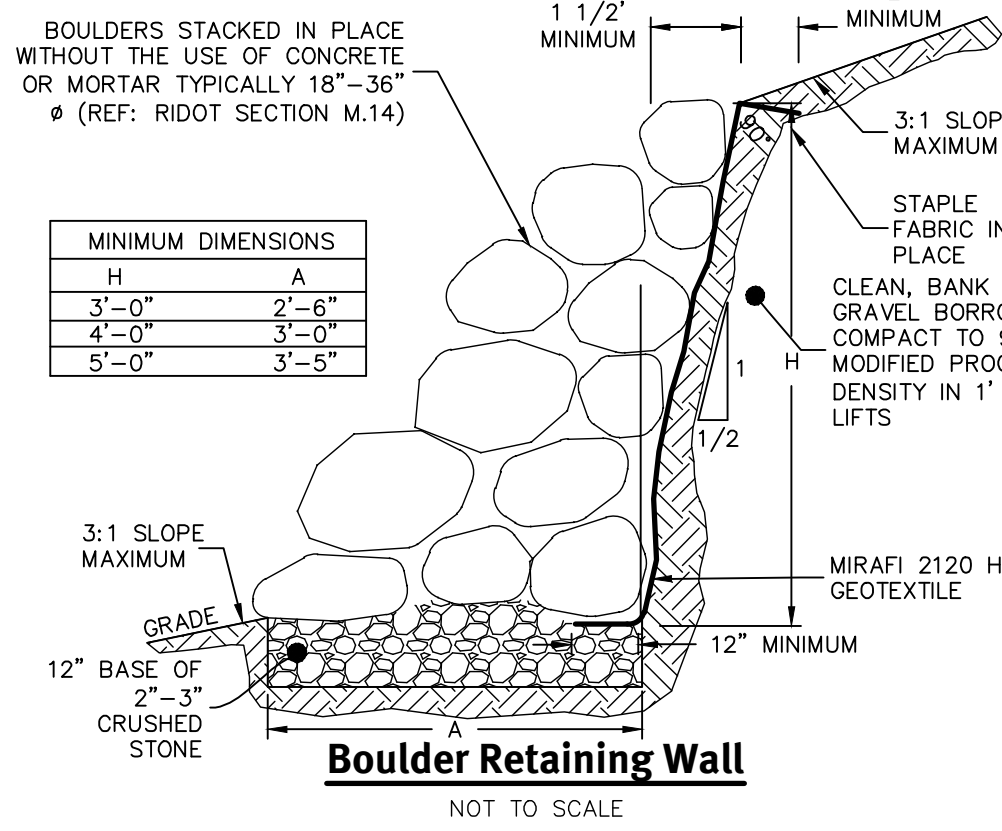

Boulder Retaining Wall
NOT TO SCALE

NOTE:
MINIMUM COMPACTION FOR GRAVEL SUBBASE OR SUBGRADE: 95% MODIFIED PROCTOR.

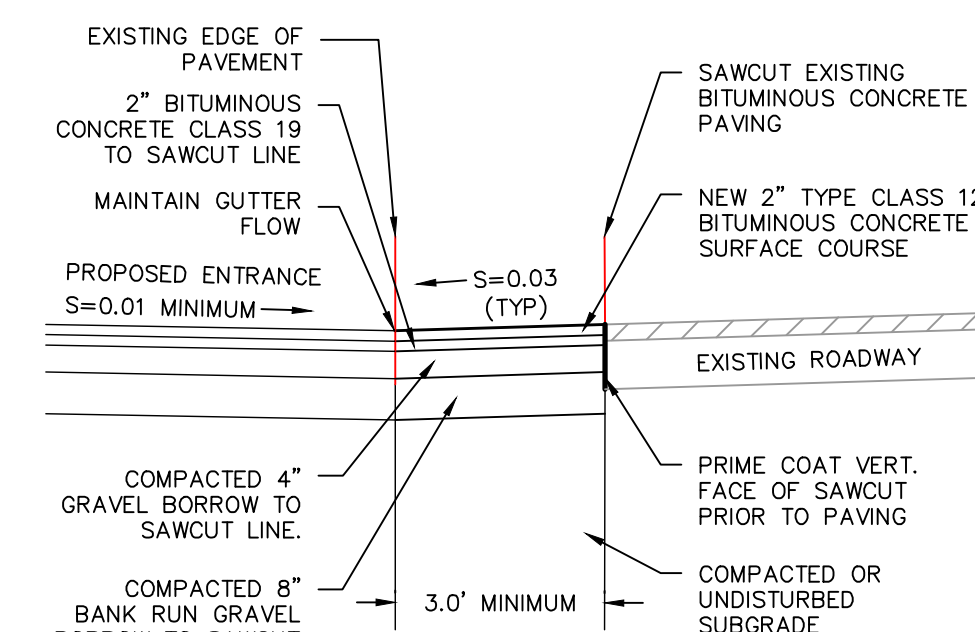

Entrance Access Sawcut & Match
NOT TO SCALE

INSTALLATION NOTES:

- ALL PIPE SYSTEMS SHALL BE INSTALLED IN ACCORDANCE WITH ASTM D2321, "STANDARD PRACTICE FOR UNDERGROUND INSTALLATION OF THERMOPLASTIC PIPE FOR SEWERS AND OTHER GRAVITY FLOW APPLICATIONS, LATEST EDITION.
- MEASURES SHOULD BE TAKEN TO PREVENT MIGRATION OF NATIVE FINES INTO BACKFILL MATERIAL, WHEN REQUIRED.
- FOUNDATION: WHERE THE TRENCH BOTTOM IS UNSTABLE, THE CONTRACTOR SHALL EXCAVATE TO A DEPTH REQUIRED BY THE ENGINEER AND REPLACE WITH SUITABLE MATERIAL AS SPECIFIED BY THE ENGINEER. AS AN ALTERNATIVE AND AT THE DISCRETION OF THE DESIGN ENGINEER, THE TRENCH BOTTOM MAY BE STABILIZED USING A GEOTEXTILE MATERIAL.
- BEDDING: SUITABLE MATERIAL SHALL BE CLASS I, II OR III. THE CONTRACTOR SHALL PROVIDE DOCUMENTATION FOR MATERIAL SPECIFICATION TO ENGINEER. UNLESS OTHERWISE NOTED BY THE ENGINEER, MINIMUM BEDDING THICKNESS SHALL BE 4" (100MM) FOR 4"-24" (100MM-600MM); 6" (150MM) FOR 30"-60" (750MM-900MM).
- INITIAL BACKFILL: SUITABLE MATERIAL SHALL BE CLASS I, II OR III IN THE PIPE ZONE EXTENDING NOT LESS THAN 6" ABOVE CROWN OF PIPE. THE CONTRACTOR SHALL PROVIDE DOCUMENTATION FOR MATERIAL SPECIFICATION TO ENGINEER. MATERIAL SHALL BE INSTALLED AS REQUIRED IN ASTM D2321, LATEST EDITION.
- MINIMUM COVER: MINIMUM COVER, H, IN NON-TRAFFIC APPLICATIONS (GRASS OR LANDSCAPE AREAS) IS 12" FROM THE TOP OF PIPE TO GROUND SURFACE. ADDITIONAL COVER MAY BE REQUIRED TO PREVENT FLOATION. FOR TRAFFIC APPLICATIONS, MINIMUM COVER, H, IS 12" UP TO 48" Ø PIPE AND 24" OF COVER FOR 54"-60" Ø PIPE, MEASURED FROM TOP OF PIPE TO BOTTOM OF FLEXIBLE PAVEMENT OR TO TOP OF RIGID PAVEMENT.

PIPE Ø	MINIMUM TRENCH WIDTH
6"	23"
8"	26"
12"	30"
15"	34"
24"	39"

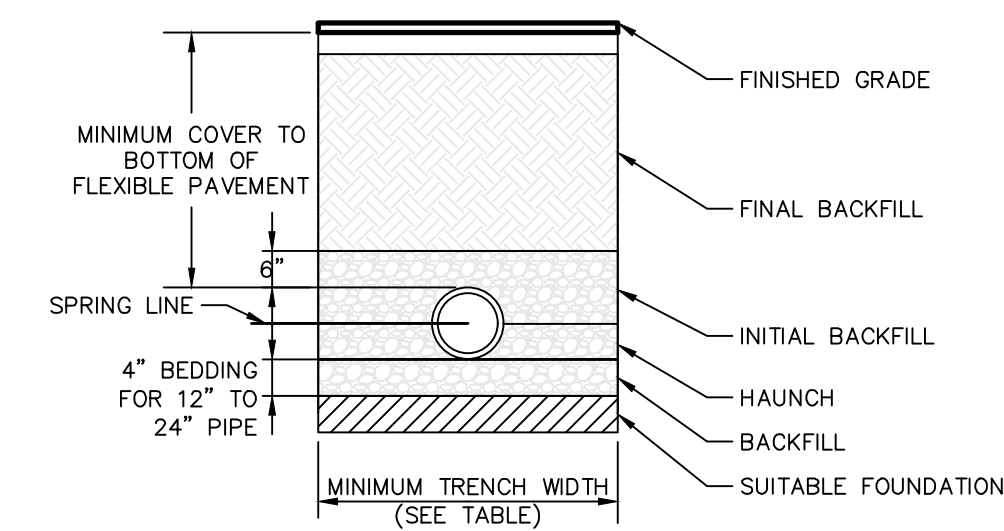

Trench Detail
NOT TO SCALE

DANDY POP® OR EQUAL

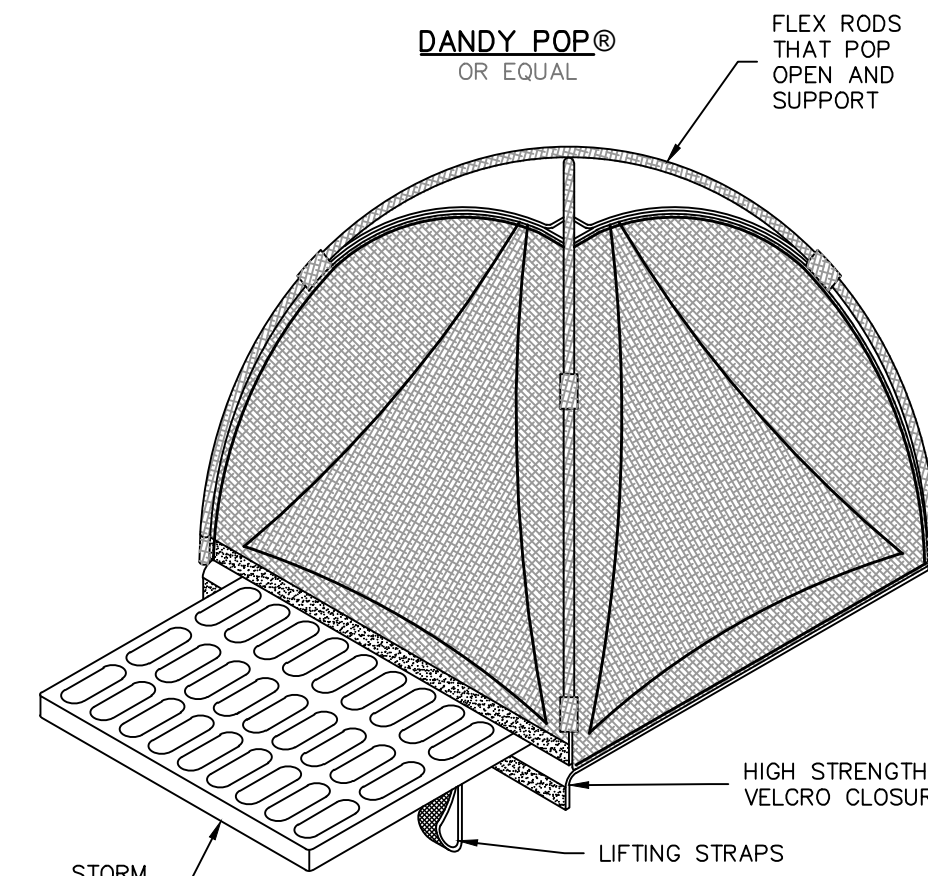

Inlet Sediment Control Devices
NOT TO SCALE

DANDY SACK® OR EQUAL

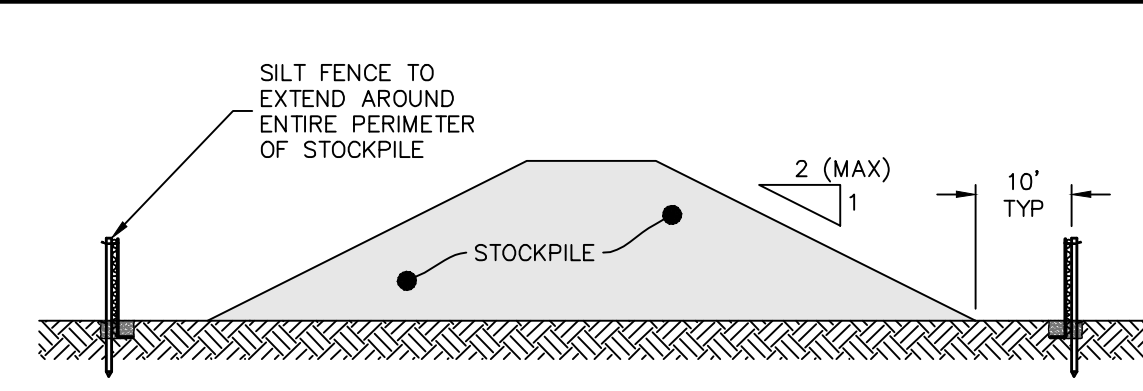
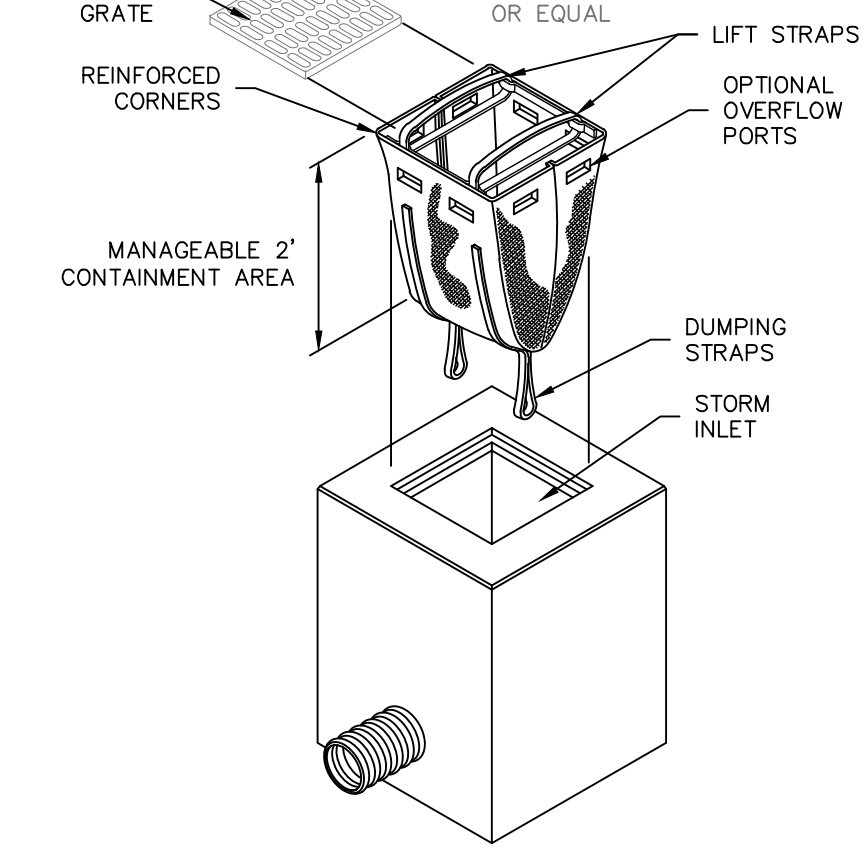

Stockpile Protection
NOT TO SCALE

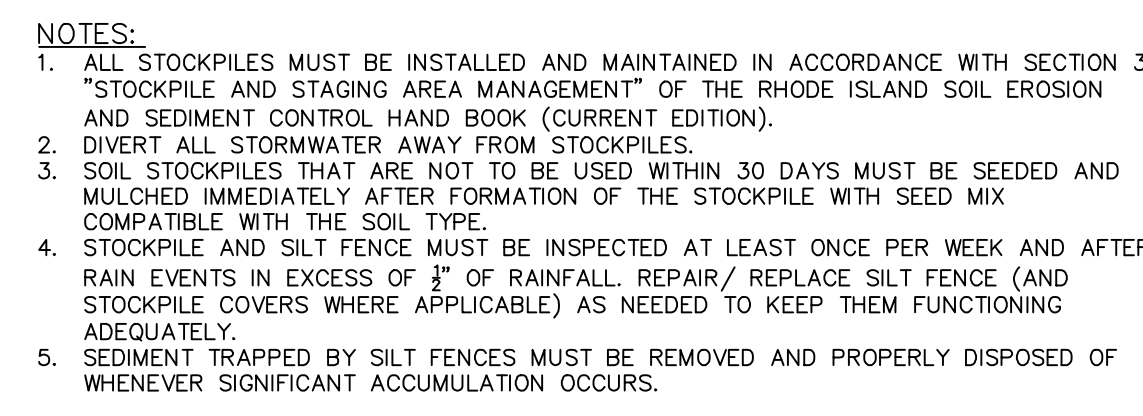

Filtrexx Sediment Control (or Approved Equal)
NOT TO SCALE

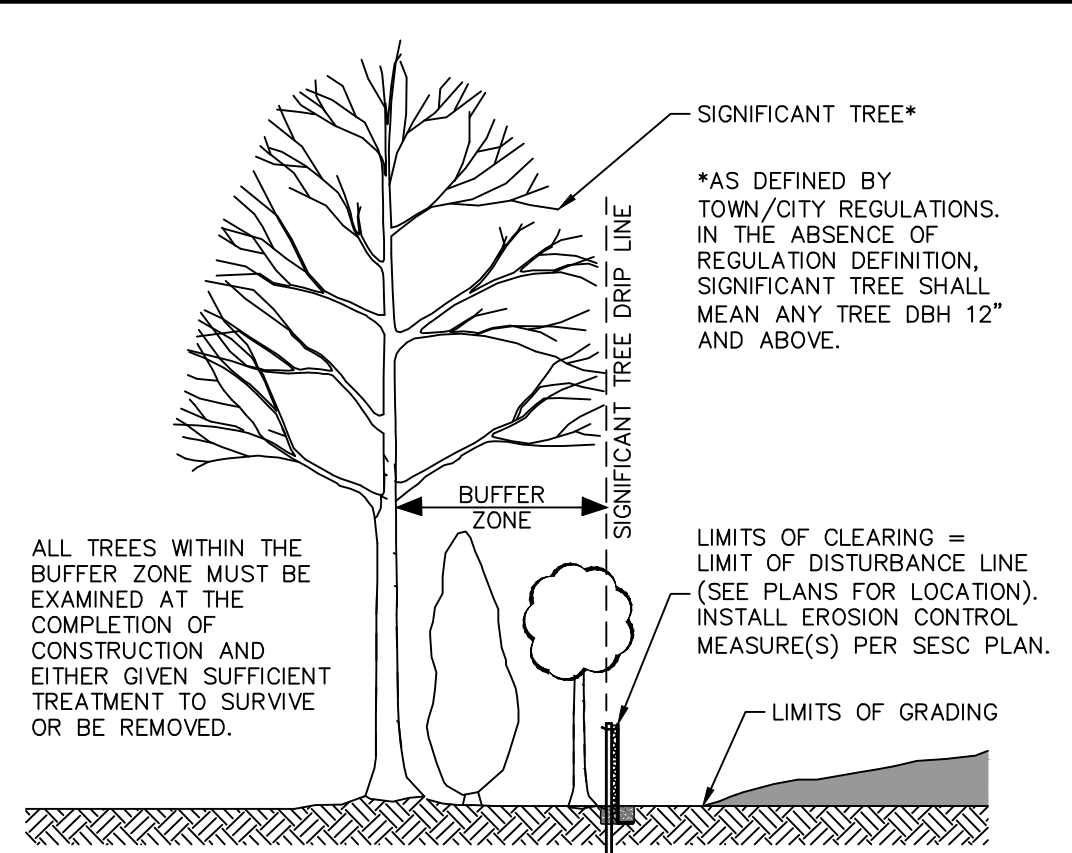

Limit of Disturbance at Vegetation
NOT TO SCALE

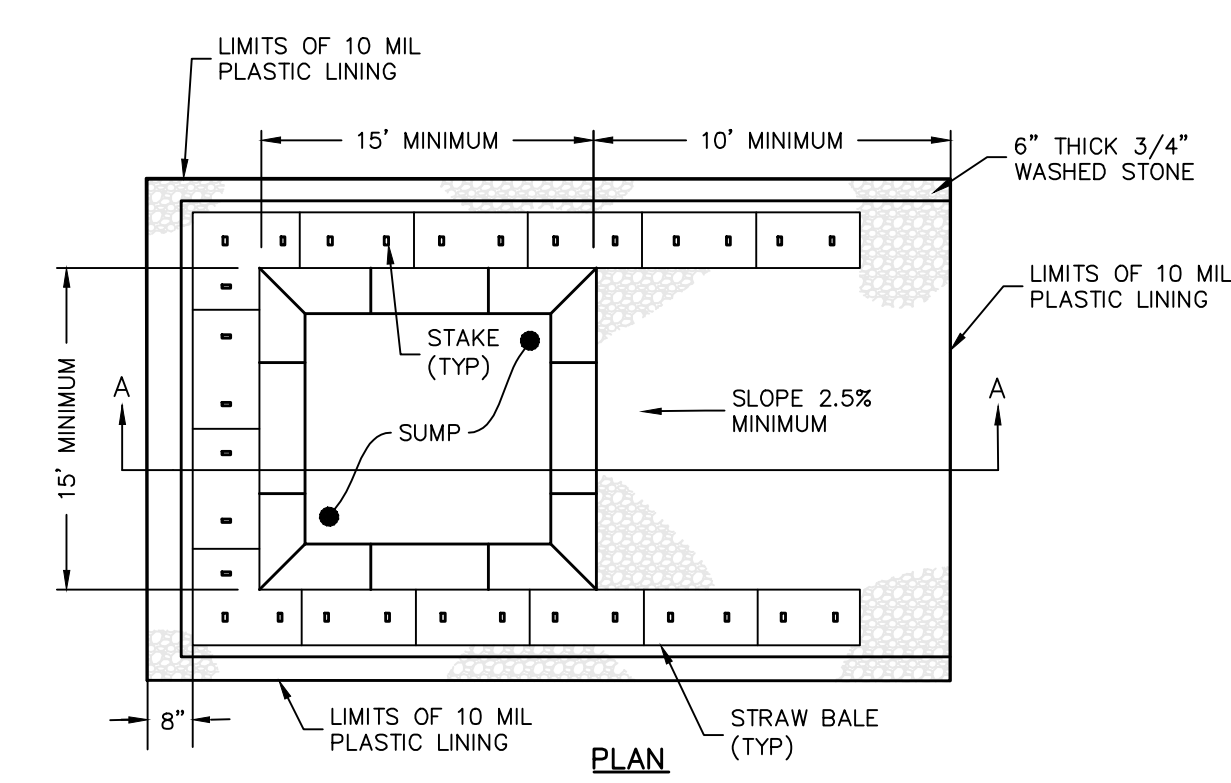

WASHOUT SIGN

Concrete Washout Area
NOT TO SCALE

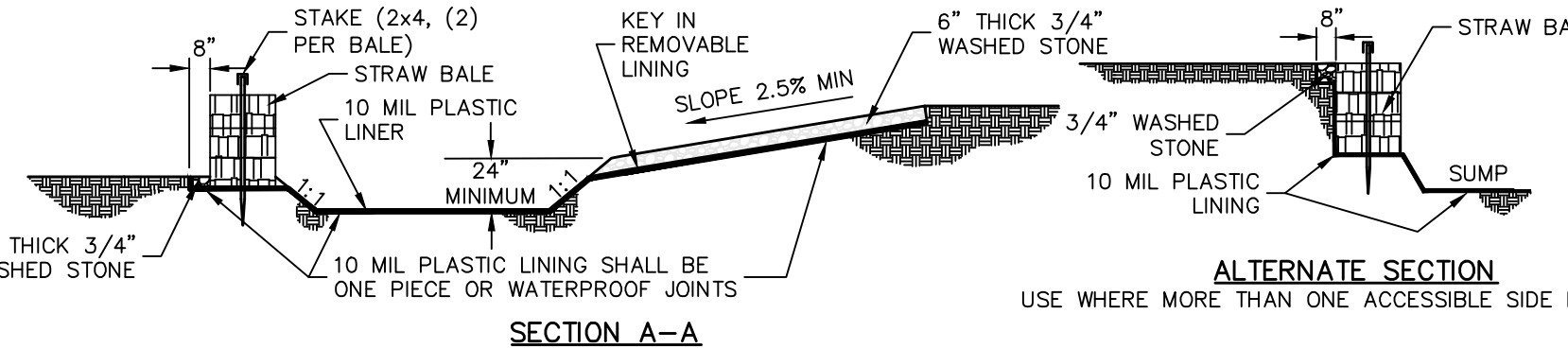

NOTES:

- PIT IS SPECIFICALLY DESIGNATED, DIKED AND IMPERVIOUS CONTAINMENT TO PREVENT CONTACT BETWEEN CONCRETE WASH AND STORMWATER.
- WASH WATER SHALL NOT BE ALLOWED TO FLOW TO SURFACE WATER.
- FACILITY MUST HOLD SUFFICIENT VOLUME TO CONTAIN CONCRETE WASTE WITH A MINIMUM FREEBOARD OF 12".
- FACILITY SHALL NOT BE FILLED BEYOND 95% CAPACITY UNLESS A NEW FACILITY IS CONSTRUCTED.
- SAWCUT PORTLAND CEMENT CONCRETE, RESIDUE FROM SAWCUT AND GRINDING TO BE DISPOSED OF IN THE PIT.
- CONCRETE WASHOUTS SHALL BE LOCATED A MINIMUM OF 100' FROM DRAINAGE WAYS, INLETS, AND SURFACE WATERS.
- MANUFACTURED CONCRETE WASHOUT DEVICES MAY BE USED IF REMOVED FROM THE SITE WHEN 95% FULL CAPACITY.

DiPrete Engineering
Two Stafford Court Cranston, RI 02920
tel 401-943-1000 fax 401-641-6006 www.diprete-eng.com

Boston • Providence • Newport

KEVIN DEMERS
REGISTERED PROFESSIONAL ENGINEER CIVIL



This regulatory submission set shall not be used for construction purposes unless stamped/issued for construction and signed by a DiPrete Engineering representative.

The contractor is responsible for all of the means, methods, safety precautions and requirements, and OSHA compliance in the implementation of this plan and design.

NO.	DATE	DESCRIPTION	BY	CHKD
1	10/28/2020	Final Submission	JMD	CJD
2	10/28/2020	Final Submission	JMD	CJD
3	10/28/2020	Final Submission	JMD	CJD
4	10/28/2020	Final Submission	JMD	CJD
5	10/28/2020	Final Submission	JMD	CJD
6	10/28/2020	Final Submission	JMD	CJD

Drawn By: J.M.F. Design By: C.H.D.

Detail Sheet: 1

The Village at Curtis Corner
40-44 West 1st St.
South Kingstown, Rhode Island

5A Builders, LLC
220 Knowledgeway Extension
Narragansett, RI 02882

DE Job No: 0265-053 Copyright 2017 by DiPrete Engineering Associates, Inc.

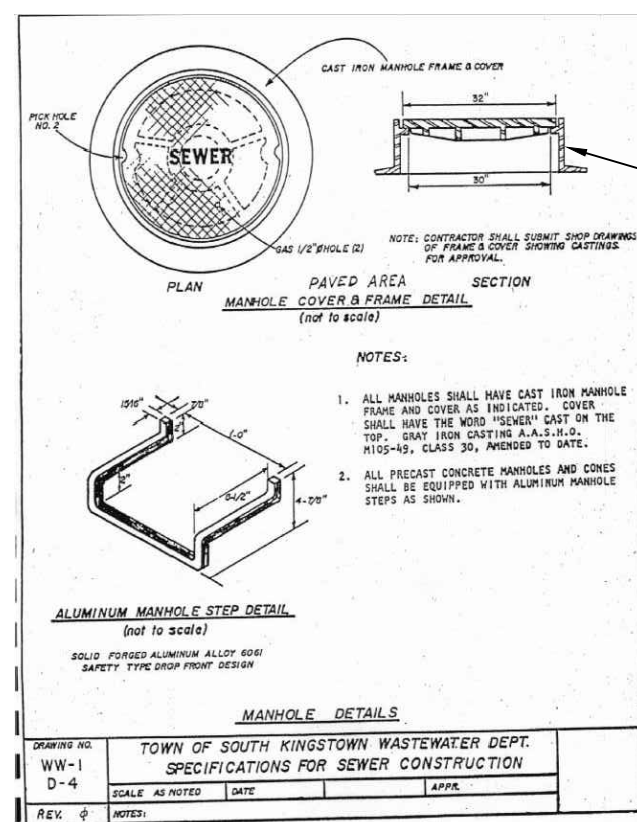

Manhole Frame & Cover Detail
NOT TO SCALE

- NOTES:**
1. MANHOLE SHALL BE MANUFACTURED IN ACCORDANCE WITH ASTM-C478.
 2. INVERT AND TABLE SHALL CONSIST ENTIRELY OF BRICK AND MORTAR. NO SAND FILLER SHALL BE ALLOWED.
 3. MANHOLES SHALL BE VACUUM TESTED PRIOR TO ACCEPTANCE, IN ACCORDANCE WITH THE SEWER AUTHORITY SANITARY RULES AND REGULATIONS. UNDER NO CIRCUMSTANCES WILL EXFILTRATION TESTING BE ACCEPTED.
 4. BOLTED AND GASKETED COVERS SHALL BE USED ON MANHOLES IN OFF-ROAD AREAS.
 5. TAPPING OF MANHOLES MUST BE AUTHORIZED AND INSPECTED BY THE SEWER AUTHORITY. THE ONLY APPROVED METHOD FOR TAPPING MANHOLES SHALL BE BY CORE-DRILLING THE MANHOLE AND INSTALLING A "KOR-N-SEAL" BOOT.
 6. PRECAST CONCRETE GRADE RINGS, HDPE GRADE RINGS, OR OTHER RIM ADJUSTMENT PRODUCTS MAY BE USED IN LIEU OF BRICK AND MORTAR WITH THE PERMISSION OF THE SEWER AUTHORITY.

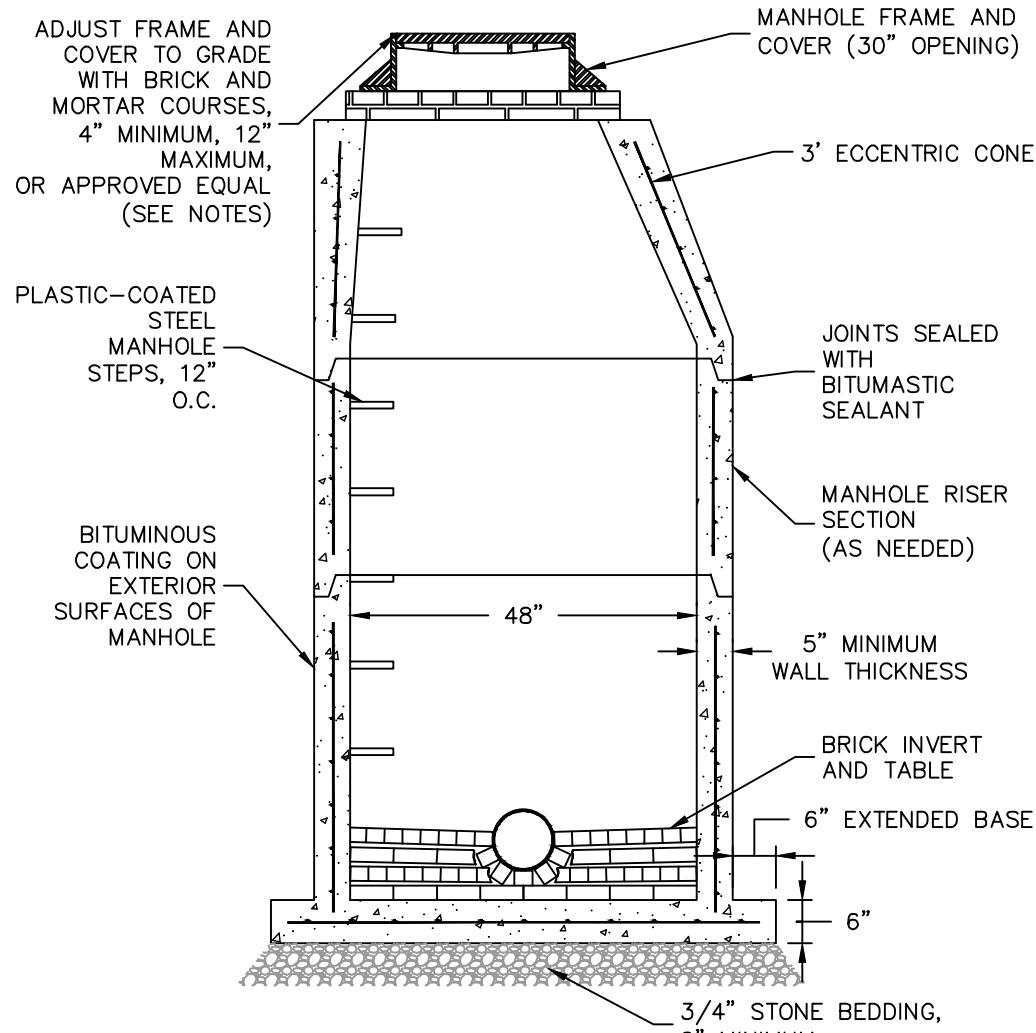

Sewer Manhole
NOT TO SCALE

Sewer Line/Water Main Separation Policy For Design Of Sanitary Sewers

A. LATERAL PLACEMENT OF SEWERS AND WATER MAINS

SEWERS SHALL BE LAID AT LEAST 10' HORIZONTALLY FROM ANY EXISTING OR PROPOSED WATER MAIN. THE DISTANCE SHALL BE MEASURED OUTSIDE EDGE-TO-OUTSIDE EDGE. THERE IS NO MINIMUM VERTICAL SEPARATION REQUIRED PROVIDED THE 10' HORIZONTAL SEPARATION IS MAINTAINED.

IN CASES WHERE IT IS NOT POSSIBLE TO MAINTAIN A 10' HORIZONTAL SEPARATION, THE DIVISION MAY ALLOW DEVIATION ON A CASE BY CASE BASIS, IF SUPPORTED BY DATA FROM THE DESIGN ENGINEER. SUCH DEVIATION MAY ALLOW INSTALLATION OF THE SEWER CLOSER TO A WATER MAIN, PROVIDED THAT:

1. THE SEWER AND WATER MAIN ARE LAID IN SEPARATE TRENCHES, OR
2. THE SEWER AND WATER MAIN MAY BE INSTALLED IN THE SAME TRENCH WITH THE WATER MAIN PLACED ON A BENCH OF UNDISTURBED EARTH, AND
3. IN EITHER CASE, THE CROWN OF THE SEWER SHALL BE AT LEAST 18" BELOW THE INVERT OF THE WATER MAIN.

IN SITUATIONS WHERE IT IS IMPOSSIBLE TO OBTAIN PROPER HORIZONTAL AND VERTICAL SEPARATION AS STIPULATED ABOVE, THE FOLLOWING PROTECTION SHALL BE PROVIDED:

4. ENCASEMENT OF THE SEWER PIPE IN CONCRETE (MINIMUM 6" THICKNESS) OR A CARRIER PIPE FOR AT LEAST 10' EITHER SIDE OF THE AREA NOT COMPLYING WITH THE MINIMUM HORIZONTAL AND VERTICAL SEPARATION, OR
5. DESIGN AND CONSTRUCTION OF THE SEWER EQUAL TO WATER MAIN PIPE (CEMENT-LINED DUCTILE IRON PIPE, PVC OR OTHER AWWA APPROVED MATERIAL FOR POTABLE WATER CONVEYANCE) FOR A DISTANCE OF 12' ON EACH SIDE OF THE CROSSING, MEASURED PERPENDICULAR TO THE WATER MAIN AND PRESSURE TESTED IN ACCORDANCE WITH AWWA SPECIFICATIONS.

B. SEWERS CROSSING WATER MAINS

SEWERS CROSSING OVER WATER MAINS SHOULD BE AVOIDED, BUT IF CONDITIONS WARRANT THIS SITUATION, THEN ADEQUATE STRUCTURAL SUPPORT SHALL BE PROVIDED FOR THE SEWER TO MAINTAIN LINE AND GRADE. SEWERS CROSSING UNDER WATER MAINS SHALL BE LAID TO PROVIDE A MINIMUM VERTICAL SEPARATION OF 18" BETWEEN THE INVERT OF THE WATER MAIN AND THE CROWN OF THE SEWER. THE CROSSING SHALL BE ARRANGED SO THAT SEWER JOINTS WILL BE EQUIDISTANT AND AS FAR AS POSSIBLE FROM THE WATER MAIN JOINTS.

WHERE CONDITIONS PREVENT AN 18" VERTICAL SEPARATION FROM BEING MAINTAINED, THE FOLLOWING METHODS SHALL BE SPECIFIED:

- A. THE SEWER SHALL BE DESIGNED AND CONSTRUCTED EQUAL TO WATER MAIN PIPE (CEMENT-LINED DUCTILE IRON PIPE, PVC OR OTHER AWWA APPROVED MATERIAL FOR POTABLE WATER CONVEYANCE) FOR A DISTANCE OF 12' ON EACH SIDE OF THE CROSSING, MEASURED PERPENDICULAR TO THE WATER MAIN AND PRESSURE TESTED IN ACCORDANCE WITH AWWA SPECIFICATIONS, OR
- B. EITHER THE WATER MAIN OR THE SEWER MAY BE ENCASED IN CONCRETE (MINIMUM 6" THICKNESS) OR A CARRIER PIPE FOR A DISTANCE OF 12' ON EACH SIDE OF THE CROSSING, MEASURED PERPENDICULAR TO THE WATER MAIN. THE CARRIER PIPE SHALL BE DESIGNED AND CONSTRUCTED OF MATERIALS WHICH ARE SATISFACTORY TO THE DIVISION, OR
- C. ANY OTHER METHODS, IF SUPPORTED BY DATA FROM THE DESIGN ENGINEER, WHICH ENSURE ADEQUATE WATER TIGHTNESS AND ARE SATISFACTORY TO THE DIVISION.

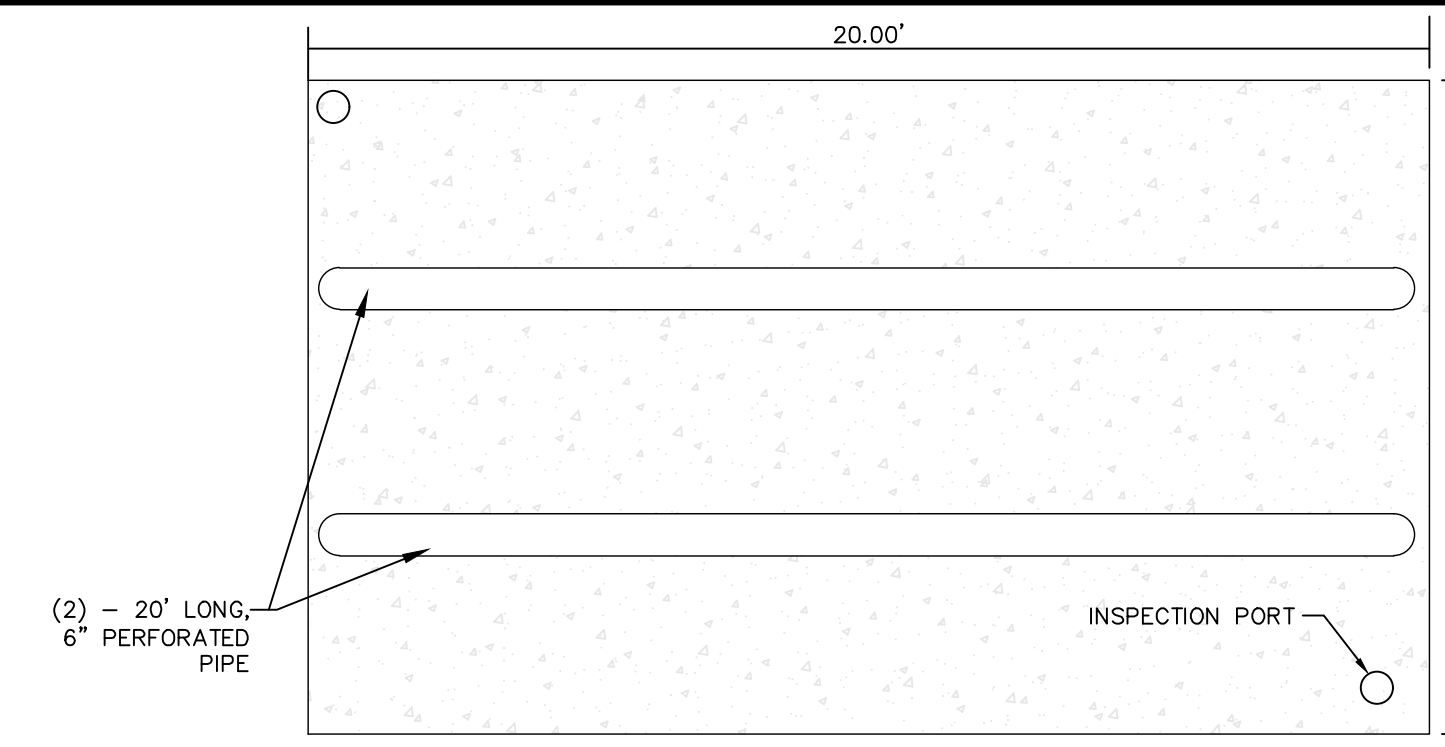

HOUSE DRYWELL DETAIL (PLAN)
NOT TO SCALE

CONSTRUCTION, MAINTENANCE, & INSPECTION NOTES:

1. ROOF LEADERS ARE TO BE TIE INTO PROPOSED DRYWELLS.
2. DRYWELL AREA TO BE STAKED, MARKED, AND REMAIN UNDISTURBED PRIOR TO CONSTRUCTION. THERE IS TO BE NO CONSTRUCTION TRAFFIC ON DESIGNATED AREA PRIOR TO CONSTRUCTION.
3. PLACE FILTER FABRIC ALONG THE BOTTOM AND SIDES OF TRENCH AND FILL WITH CRUSHED, WASHED STONE.
4. OVERLAP FILTER FABRIC ON THE TOP OF THE FILTER STONE. BACK FILL WITH CLEAN FILL TO FINISH GRADE.
5. (*) MONITORING WATER LEVELS WITHIN THE INSPECTION PORT AT VARIOUS TIME INTERVALS AFTER A RAINFALL EVENT WILL INDICATE THE EFFECTIVENESS OF THE SYSTEM. IF WATER IS STANDING IN DRYWELL SYSTEM 72 HOURS AFTER A STORM EVENT, SYSTEM FAILURE HAS OCCURRED AND WILL REQUIRE FLUSHING MAINTENANCE, REPAIR OR REPLACEMENT OF THE SYSTEM. THE OWNER WILL MAINTAIN THE DRAINAGE COMPONENTS.

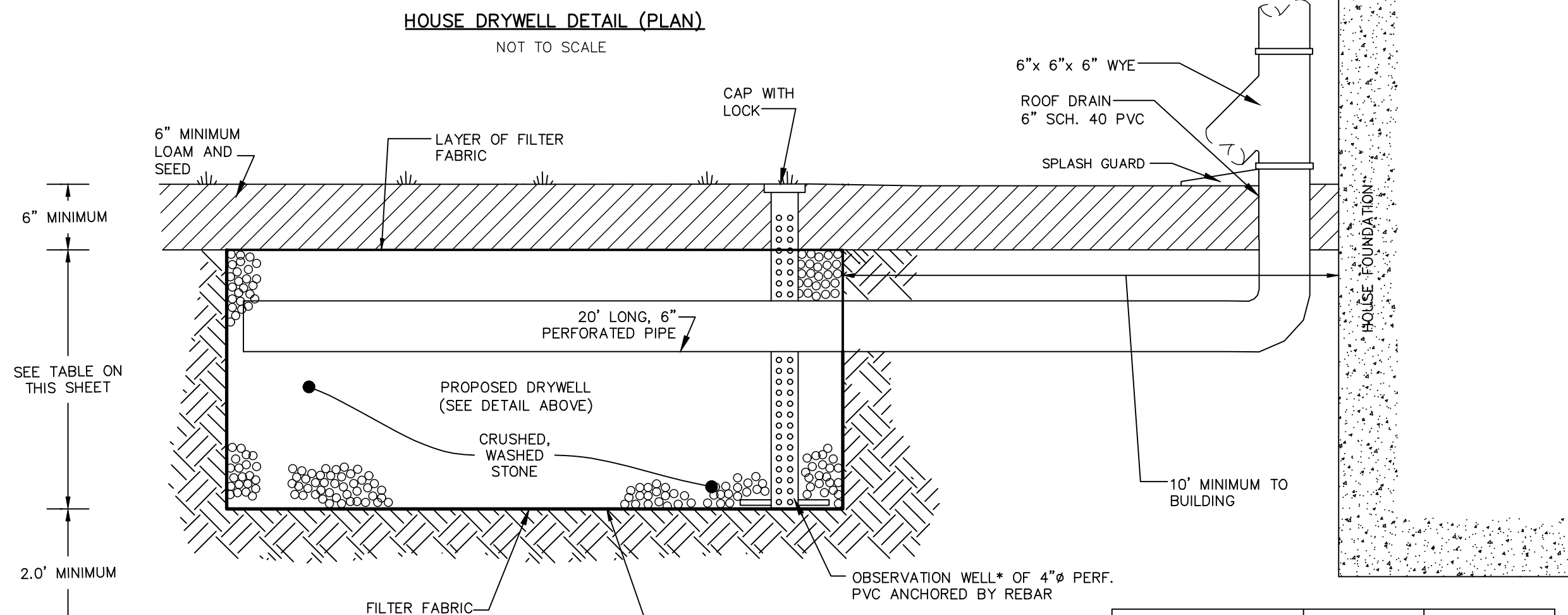

House Drywell Connection Detail
NOT TO SCALE

LOCATION	BOTTOM OF STONE ELEV.	TOP OF STONE ELEV.
LOT 2 (DRYWELL C1)	109.50	112.50
LOT 1 (DRYWELL C2)	108.50	111.50
LOT 21 (DRYWELL C3)	112.50	115.50
LOT 22 (DRYWELL C4)	110.00	113.00
LOT 23 (DRYWELL C5)	109.00	112.00
LOT 24 (DRYWELL C6)	111.50	114.50

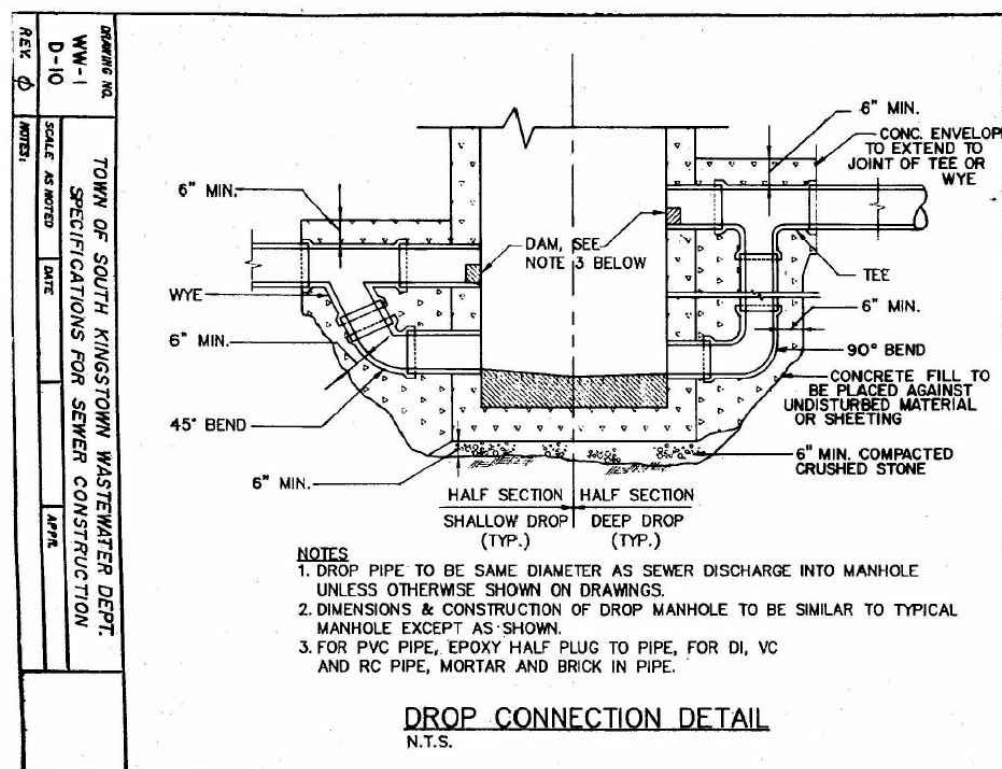

Drop Connection Detail
NOT TO SCALE

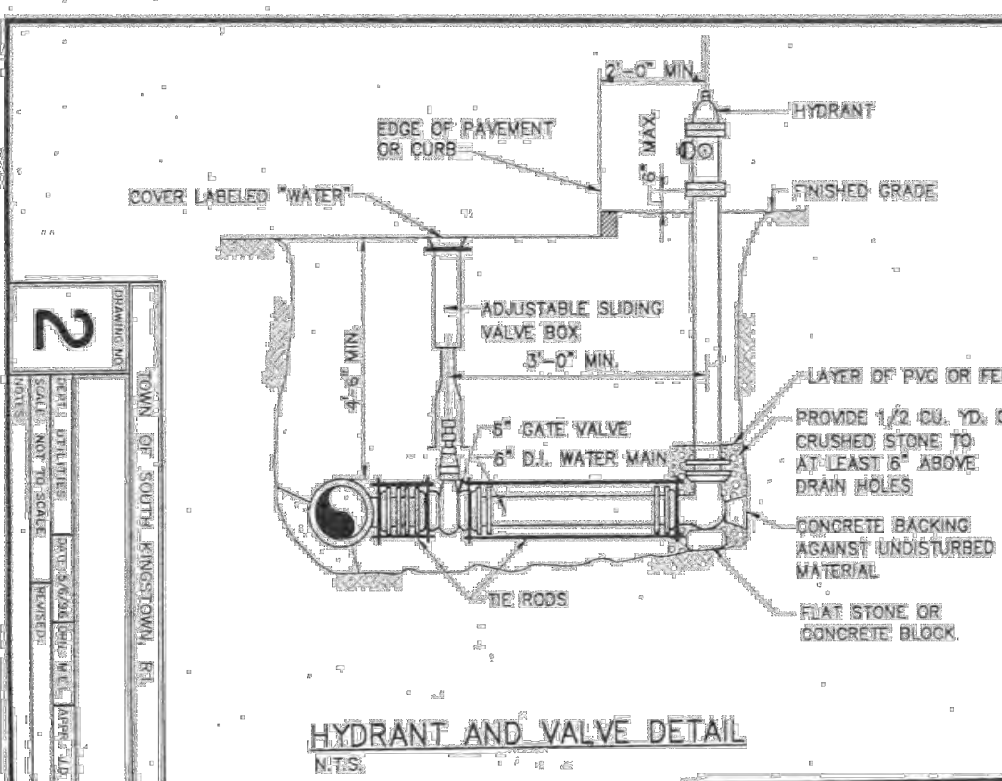

Hydrant and Valve Detail
NOT TO SCALE

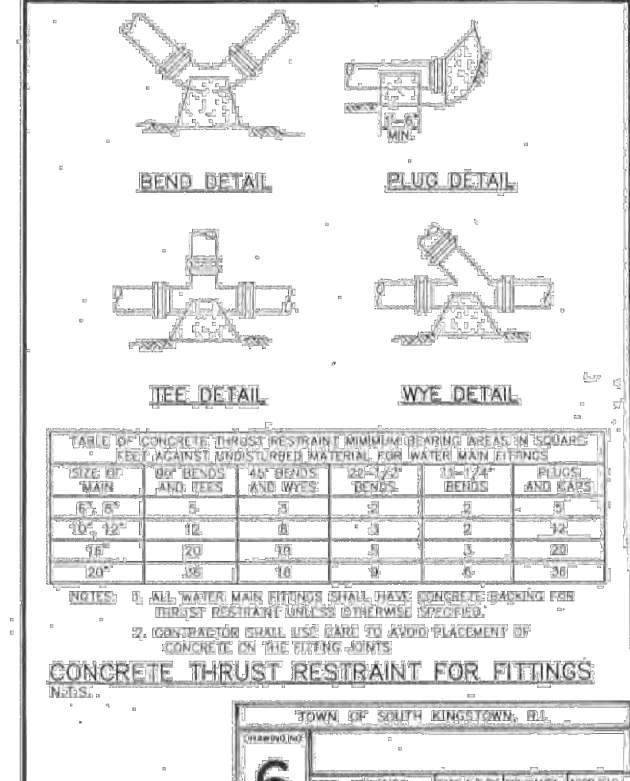

Thrust Block
NOT TO SCALE

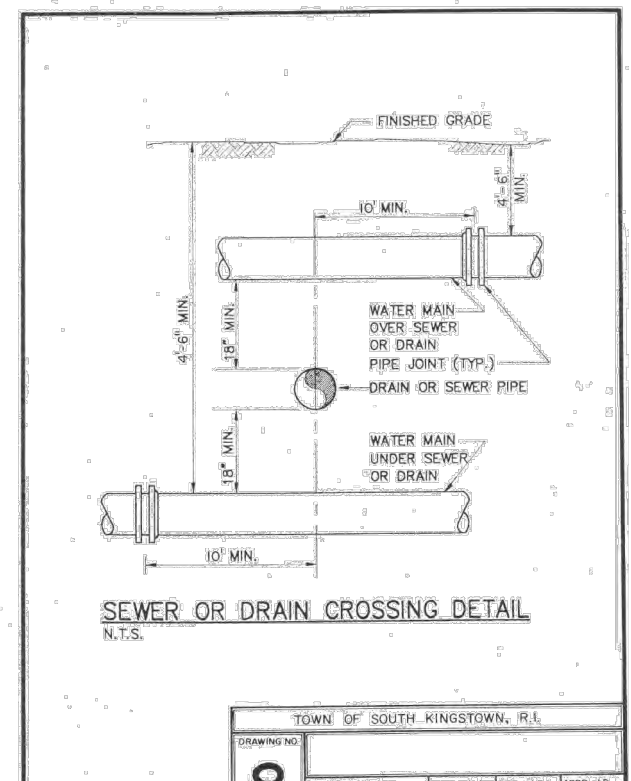

Sewer/Drain Crossing Detail
NOT TO SCALE

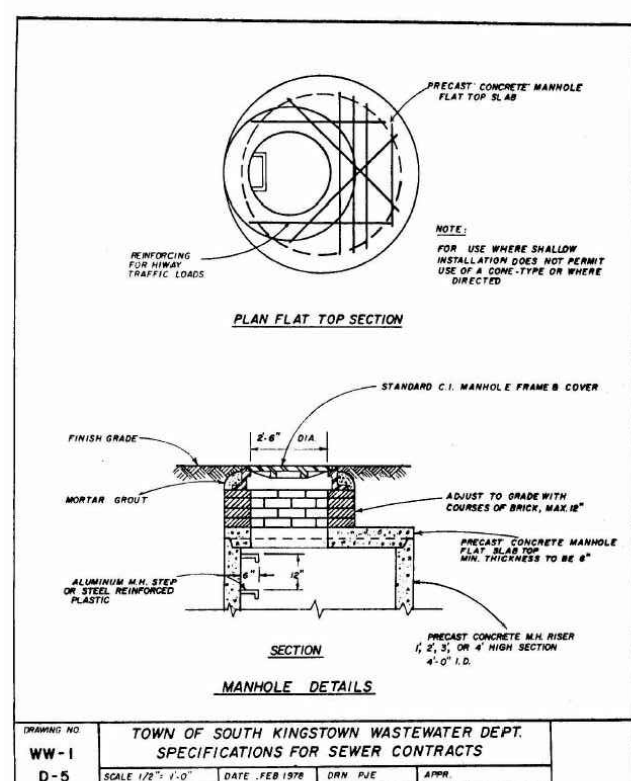

Flat Top Manhole Detail
NOT TO SCALE

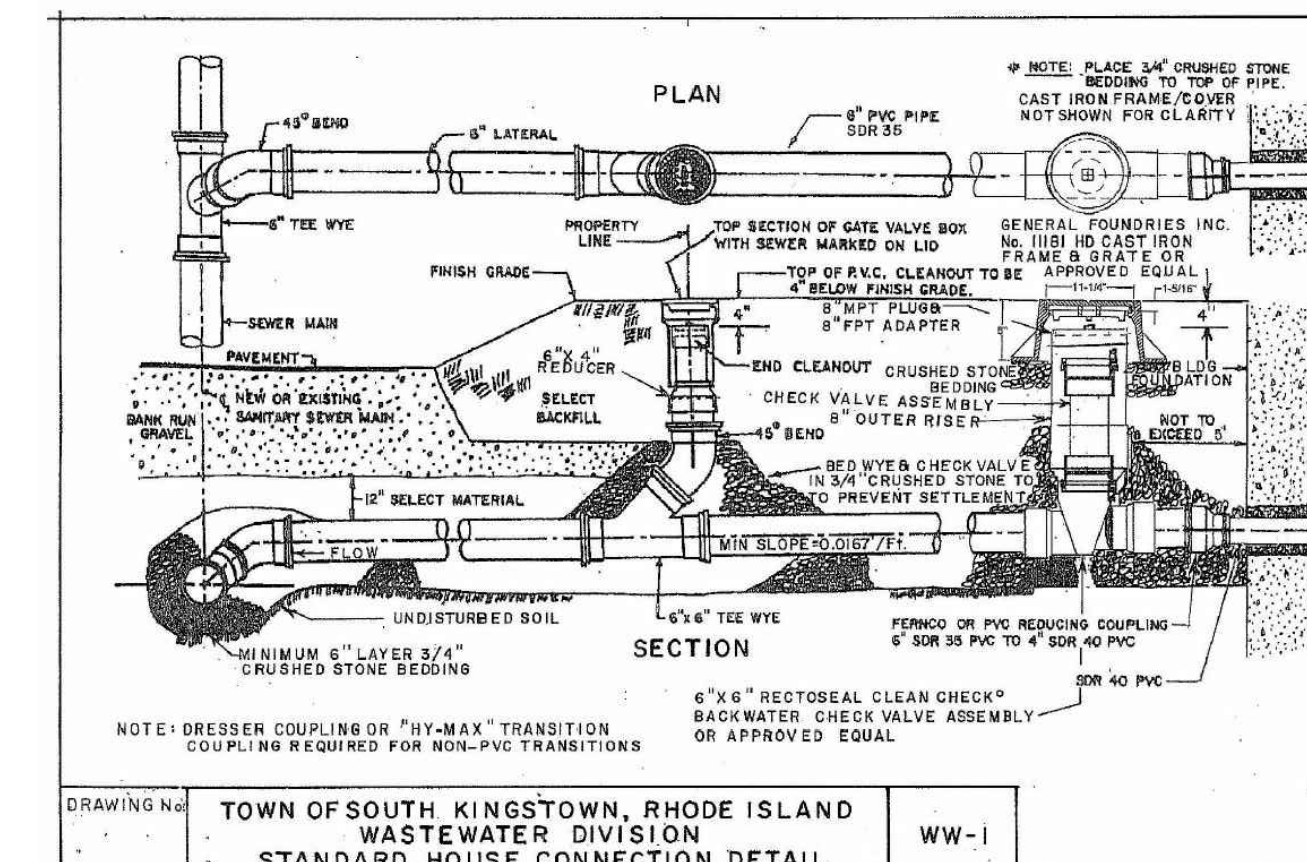

Standard House Connection Detail
NOT TO SCALE

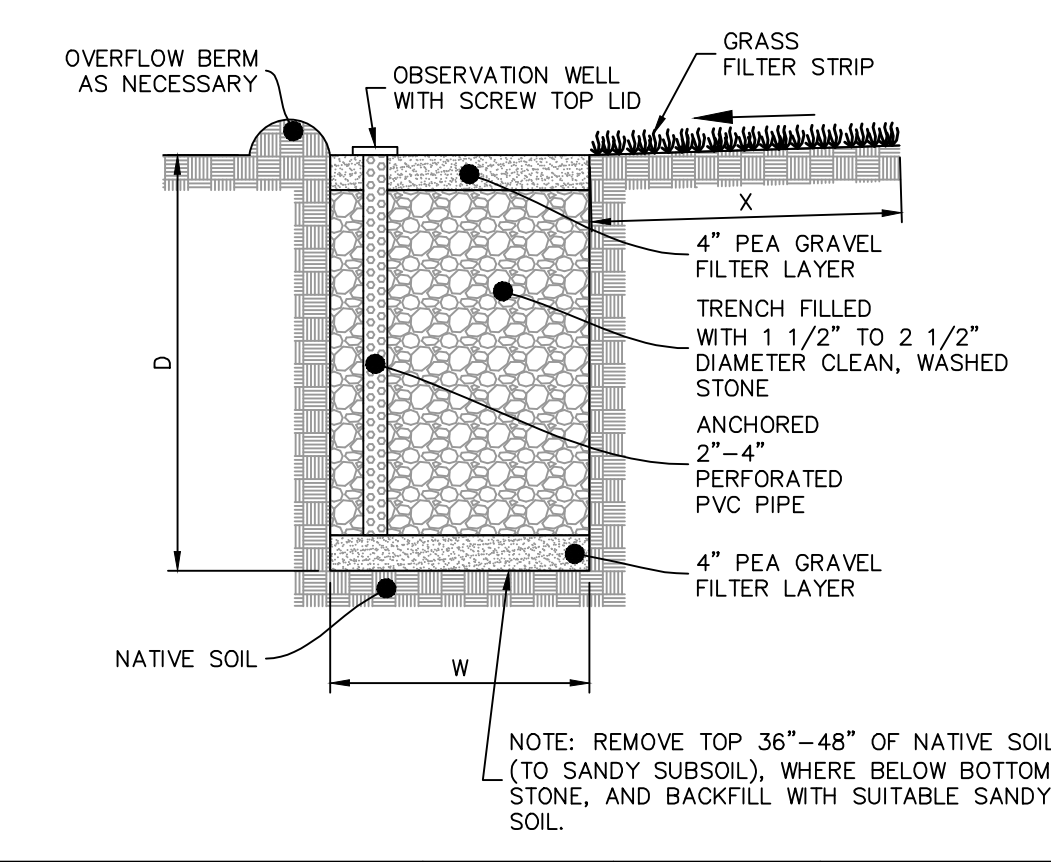

LOCATION	TRENCH DEPTH (D)	AVG TRENCH WIDTH (W)	GRASS FILTER STRIP WIDTH (X)
LOT 24 (INFILTRATION TRENCH D1)	9"	19"	2'
LOT 23 (INFILTRATION TRENCH D2)	9"	19"	2'
LOT 22 (INFILTRATION TRENCH D3)	9"	16"	2'
LOT 21 (INFILTRATION TRENCH D4)	9"	20"	2'
LOT 2 (INFILTRATION TRENCH D5)	9"	5"	2'
LOT 1 (INFILTRATION TRENCH D6)	9"	5"	2'
LOT 20 (INFILTRATION TRENCH D7)	9"	8"	2'

* NOTE: WIDTH VARIES. SEE SHEET 9 FOR EXACT TRENCH LIMITS.

Stone Infiltration Trench Detail
NOT TO SCALE

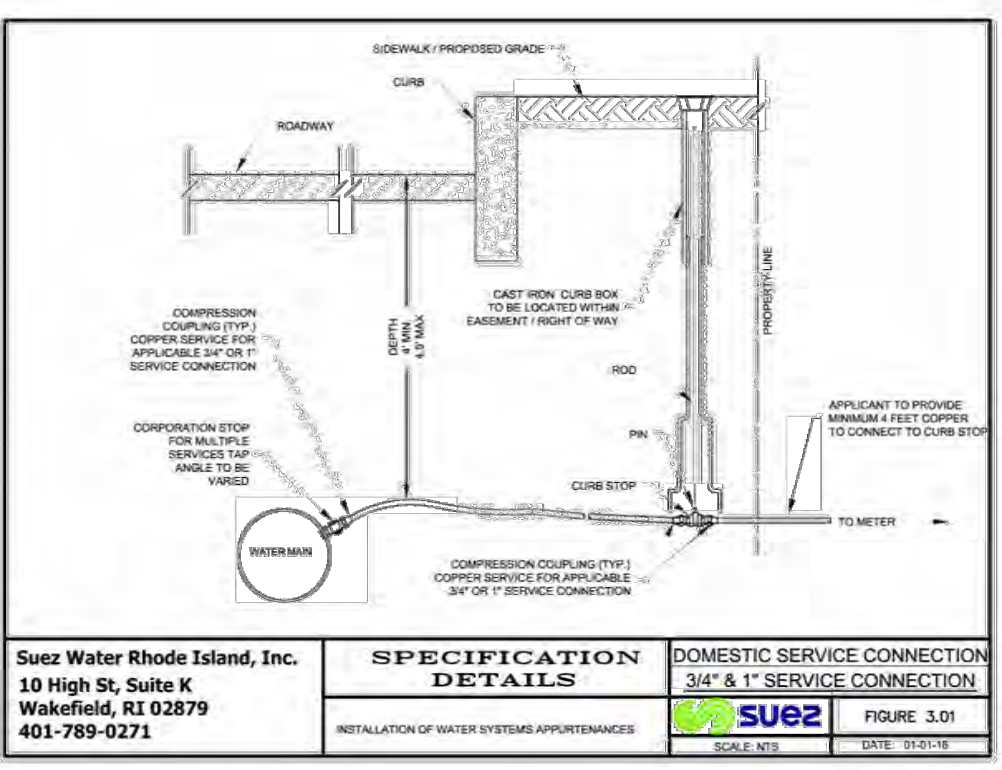

Water Service Detail
NOT TO SCALE

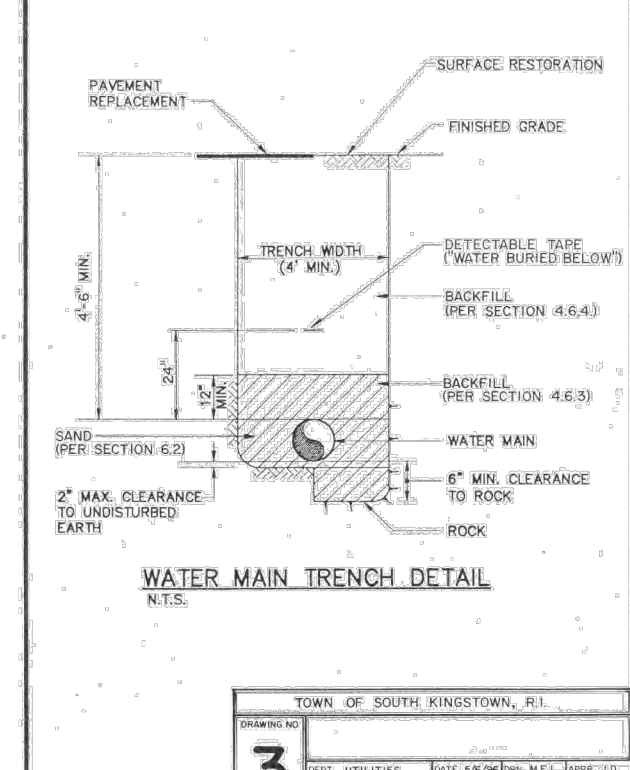

Water Trench Detail
NOT TO SCALE

Materials List and Requirements for Main Extensions and Service Installations

THE SWRI SYSTEM IS OPEN RIGHT (CLOCKWISE)
All materials to be used for water main construction shall conform to Company standards, meet AWWA standards and meet RIDOH requirements, including but not limited to:

1. Pipe shall be cement-lined Ductile Iron Class 52 Pipe or C900 PVC rated 235 psi (DR-18) or higher and conforming with AWWA standards. Pipe material will be determined by Superintendent depending on proposed development.
2. Fittings shall be class 52 DI AWWA standards C110 and C111.
3. All fittings shall be DI mechanical joint restraint (series 1100 MEGALUG).
4. Hydrants shall be 3-way Super Centurion Mueller model A-423 with 5-1/2" main valve, one pump nozzle and 2-1/2" hose connections with 250 psi working pressure, open right and yellow in color.
5. Valves shall be Mueller 2362 Series Resilient Wedge MJ style gate valve, all valves open right installed with series 1100 MEGALUG MJ Restraint.
6. Valve Boxes shall be Cast Iron, 5-14" two piece style type.
7. Valve Covers shall be constructed Cast Iron and Cast Iron top manufactured to read WATER.
8. Service lines shall be 1" copper tubing rated for 200 psi minimum.
9. Corporation stops and curb stops 1" diameter and suitable for use with copper or plastic (PE) tubing.
10. Curb boxes should be Eire Style box and rod assembly.
11. Blowoff assemblies shall be 2" GI style.
12. 1" service connections requiring meter pits shall utilize meter pits for cold climates assembled/manufactured by Wawvic WinWater.



Pressure Testing

After installation is complete, water mains shall be pressured tested to 2 times the working pressure or 200 psi, whichever is greater, and held for 2 hours at test pressure as per the requirements of Suez, AWWA, NFPA and RIDOH.

Disinfection

Disinfection of the pipe interior will be done under the supervision of a Suez inspector following hydrostatic pressure testing and the installation of chlorination taps furnished and installed by the Contractor. Disinfection is to be performed in accordance with ANSI/AWWA C651-05 standards utilizing liquid sodium hypochlorite solutions.

After final flushing and before the new water main is connected to the distribution system, two consecutive sets of acceptable samples, taken at least 24 hours apart, shall be collected and taken to a laboratory approved by the Company for bacteriological analysis. At least one sample set shall be taken from each 1,200 linear feet of water main or portion thereof.

All samples shall be tested for bacteriological (physical and chemical) quality in accordance with the Standard Methods for Examination of Water and Wastewater and shall show the absence of coliform organisms. If the samples fail to meet the Standards for drinking water, then the water main shall be re-sterilized, and the procedures repeated until the samples are satisfactory.

After disinfection is completed, contractor must remove chlorination whips at the tap and the corporations turned off.

Please reach out to Mark Dowell or Bob Pike at 789-0271 with questions.
Email: mark.dowell@suez.com

Updated August 2020

DiPrete Engineering
Two Stafford Court Cranston, RI 02920
Tel: 401-943-1000 Fax: 401-943-6006 www.diprete-eng.com

KEVIN DEMERS
REGISTERED PROFESSIONAL ENGINEER CIVIL



LOCATION MAP N.T.S.

This regulatory submission set shall not be used for construction purposes unless stamped 'Issued for Construction' and signed by a DiPrete Engineering representative.

The contractor is responsible for all of the means, methods, safety precautions and requirements, and OSHA compliance in the implementation of this plan and design.

Drawn By: J.M.F. Design By: C.H.D.

Detail Sheet - 2
The Village at Curtis Corner
Accession Plot 40-14-15
South Kingstown, Rhode Island
Application Owner:
5A Builders, LLC
220 Knowledgeway Extension
Narragansett, RI 02882

PROFILE GRADE	T
0.00	7.5
0.01	9.0
0.02	11.0
0.03	13.5
0.04	19.0
0.05	30.0

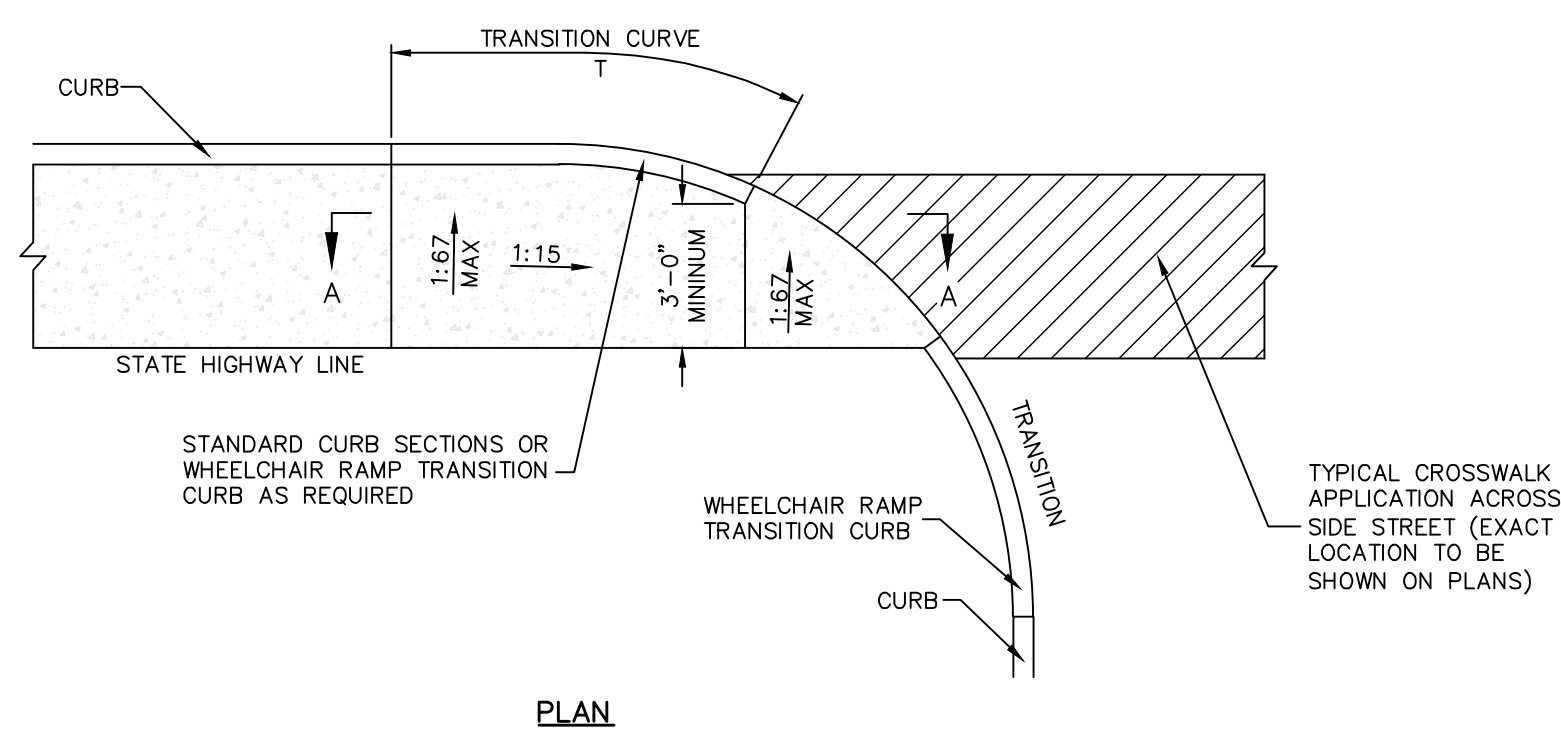

PLAN

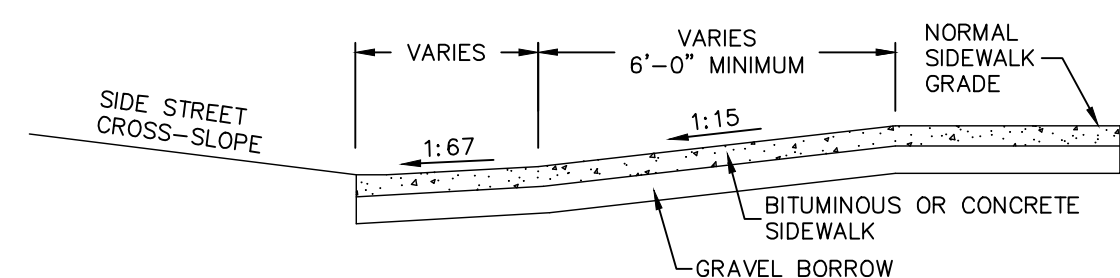

SECTION A-A

NOTES:

1. SHALL BE IN ACCORDANCE WITH SECTION 904 OF THE R.I. STANDARD SPECIFICATIONS.
2. THIS DETAIL IS TO BE USED ONLY WHEN STATE RIGHT-OF-WAY IS LIMITED TO BACK OF SIDEWALK, AND SIDEWALK IS NARROW WITH NO PEDESTRIAN TRAFFIC FROM SIDE STREET.
3. WHEN ANY OBSTRUCTION LOCATED IN THE SIDEWALK FALLS WITHIN A CROSSWALK AREA, IF POSSIBLE, THE OBSTRUCTION WILL BE PLACED SUCH THAT IT FALLS OUTSIDE OF THE RAMP.
4. AT NO TIME IS ANY PART OF THE WHEELCHAIR RAMP TO BE LOCATED OUTSIDE OF THE CROSSWALK, AND IT IS TO BE CENTERED WHENEVER POSSIBLE.
5. DRAINAGE FACILITIES ARE TO BE LOCATED UP-GRADE OF ALL WHEELCHAIR RAMPS.
6. LOCATION OF WHEELCHAIR RAMPS IS AS SHOWN ON CONTRACT DRAWINGS.
7. ALL REQUIRED CUTTING OF CURB PIECES TO BE PAID FOR UNDER COST OF CURB.
8. THE ENTRANCE OF THE WHEELCHAIR RAMP SHALL BE FLUSH WITH THE ROADWAY.
9. MINIMUM LENGTH OF STRAIGHT OR CIRCULAR FILLER PIECES TO BE 3'-0" (GREATER LENGTHS PREFERRED).
10. AN UNOBSTRUCTED PATH OF TRAVEL WITH A MINIMUM WIDTH OF 3'-0" SHALL BE MAINTAINED.
11. MEETS OR EXCEEDS GUIDELINES OF RIDOT STANDARD DETAIL 43.3.1.

**Wheelchair Ramp
For Limited Right-Of-Way Areas (ADA)**

NOT TO SCALE

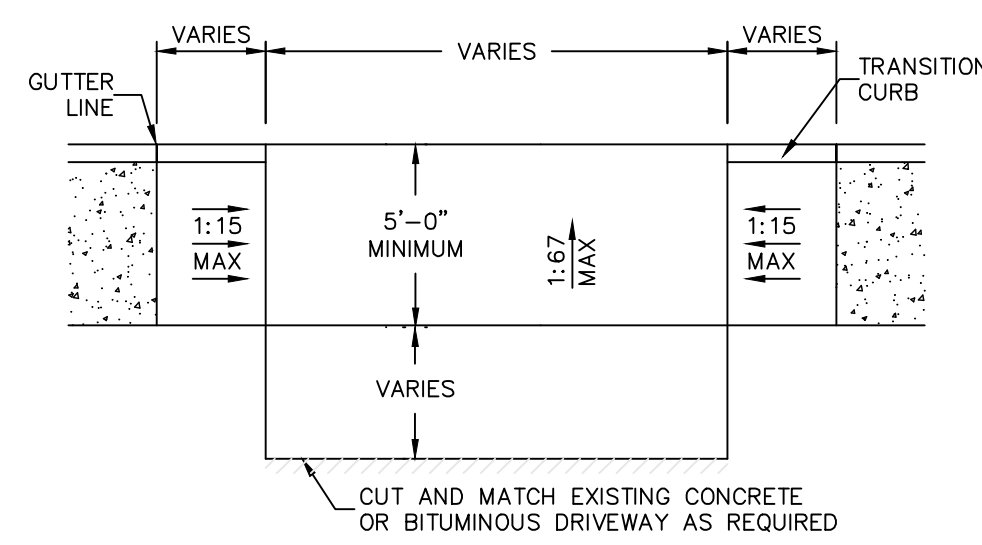

PLAN

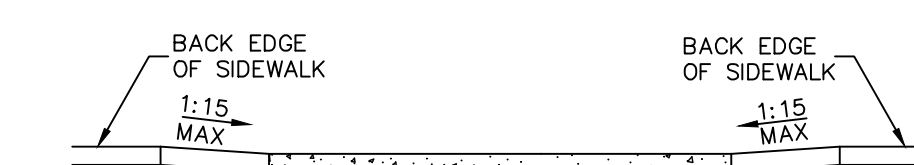

ELEVATION

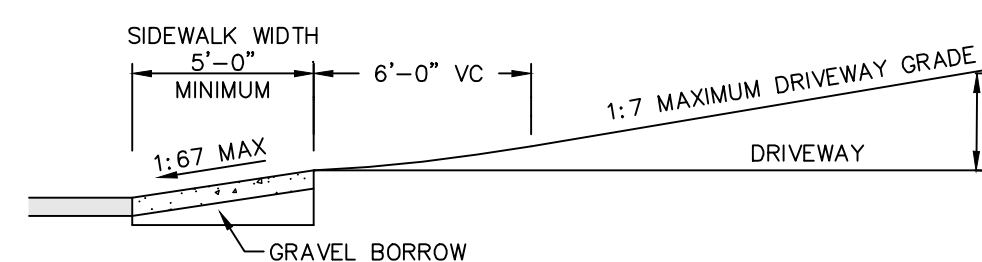

SECTION

NOTES:

1. SHALL BE IN ACCORDANCE WITH SECTION 905 OF THE R.I. STANDARD SPECIFICATIONS.
2. MEETS OR EXCEEDS GUIDELINES OF RIDOT STANDARD DETAIL 43.4.0 AND 43.4.1.

**Driveway Development For
Transition Curb (ADA)**

NOT TO SCALE

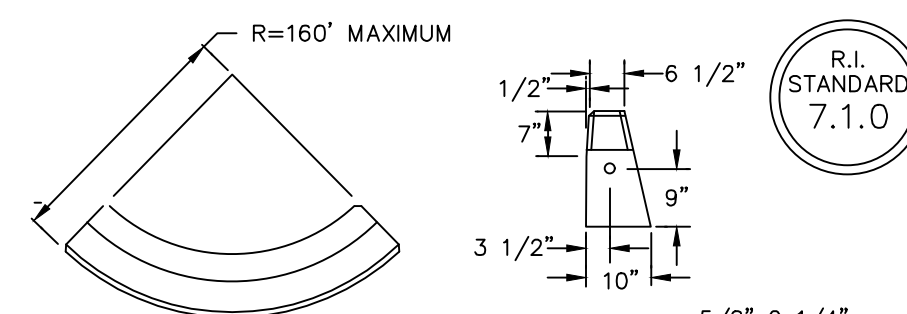

CIRCULAR CURB

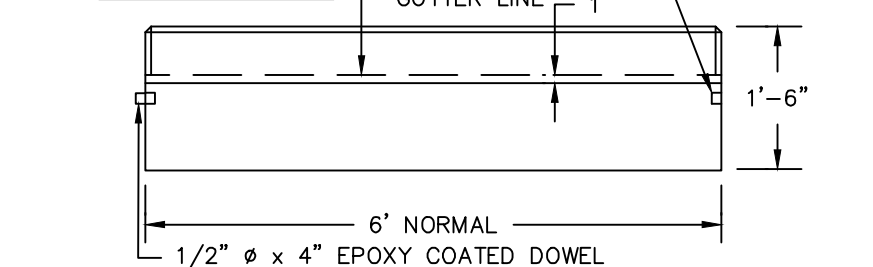

NOTES:

1. SHALL BE IN ACCORDANCE WITH SECTION 905 OF THE R.I. STANDARD SPECIFICATIONS.
2. MINIMUM LENGTH OF STRAIGHT OR CIRCULAR FILLER PIECES TO BE 3'-0".
3. EXPOSED SURFACES TO HAVE A SPONGE FLOAT FINISH.
4. CIRCULAR CURB IS REQUIRED ON CURVES WITH RADI OF 160'-0" OR LESS. STRAIGHT CURB TO BE USED ON CURVES OF MORE THAN 160'-0" RADIUS.
5. EXPOSED EDGES TO HAVE A 3/4" CHAMFER.

Precast Concrete Curb

NOT TO SCALE

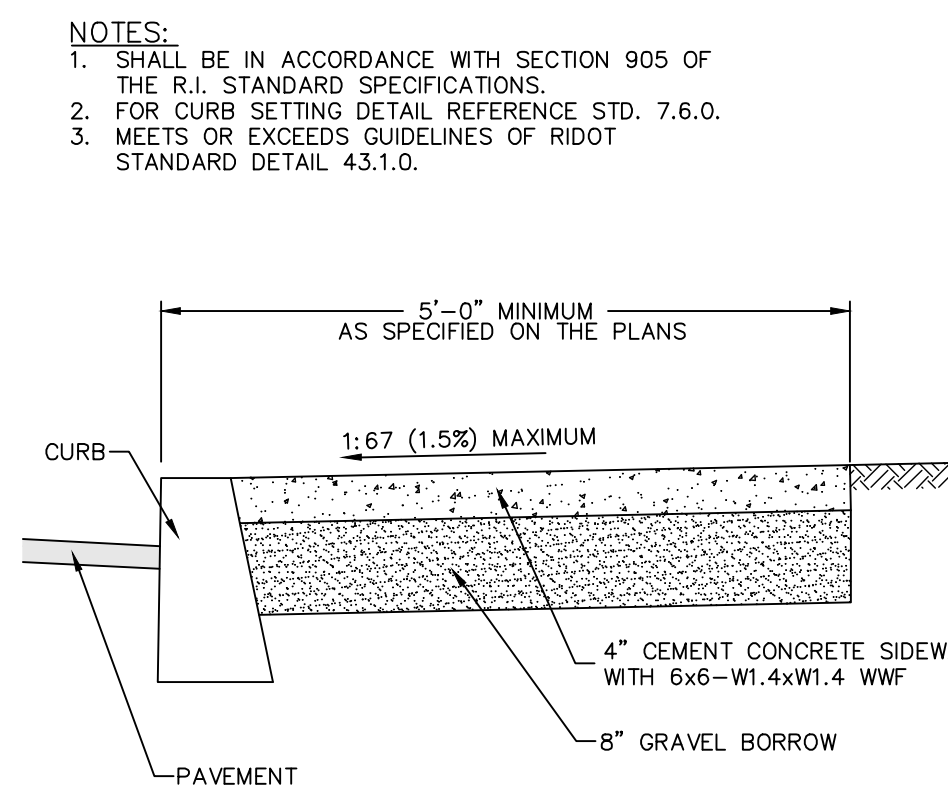

Cement Concrete Sidewalk

NOT TO SCALE

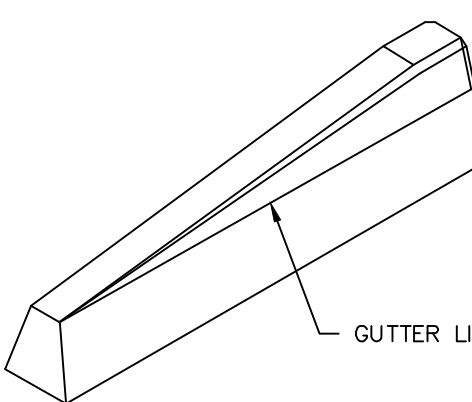

6' Precast Concrete Transition Curb

NOT TO SCALE

NOTES:

1. SHALL BE IN ACCORDANCE WITH SECTION 906 OF THE R.I. STANDARD SPECIFICATIONS.
2. DRAWING SHOWS TRANSITION CURB FOR ONE DIRECTION. FOR OTHER DIRECTION USE OPPOSITE HAND AND INCLUDE A 1/2" x 4" EPOXY COATED DOWEL.
3. EXPOSED SURFACES TO HAVE A SPONGE FLOAT FINISH.
4. EXPOSED EDGES TO HAVE A 3/4" CHAMFER.

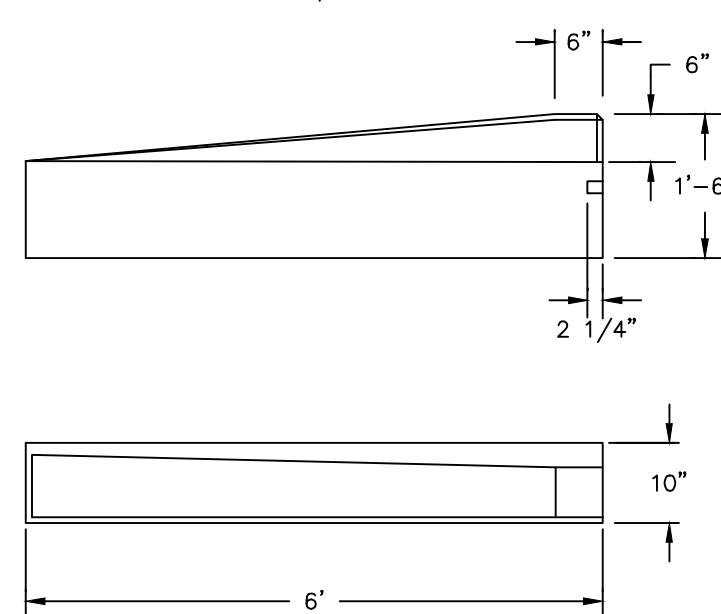

6' Precast Concrete Transition Curb

NOT TO SCALE

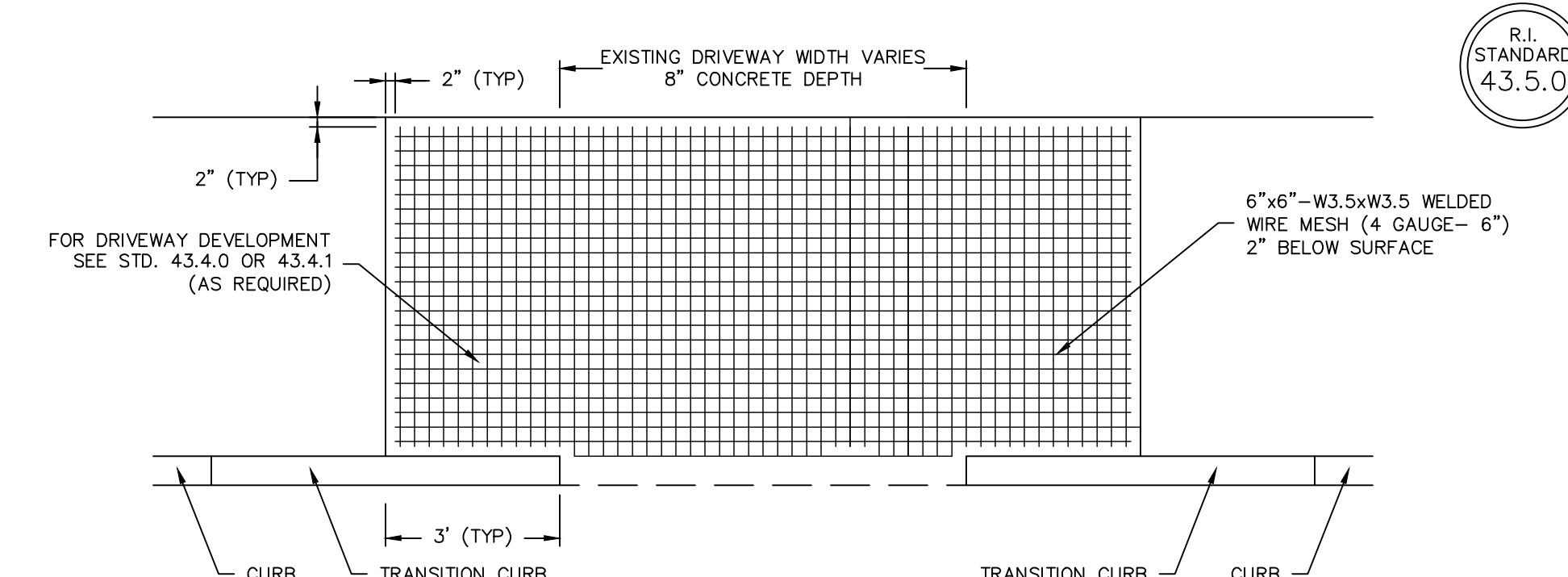

NOTE:
SHALL BE IN ACCORDANCE WITH SECTION 904 OF THE R.I. STANDARD SPECIFICATIONS.

Cement Concrete Driveways

NOT TO SCALE

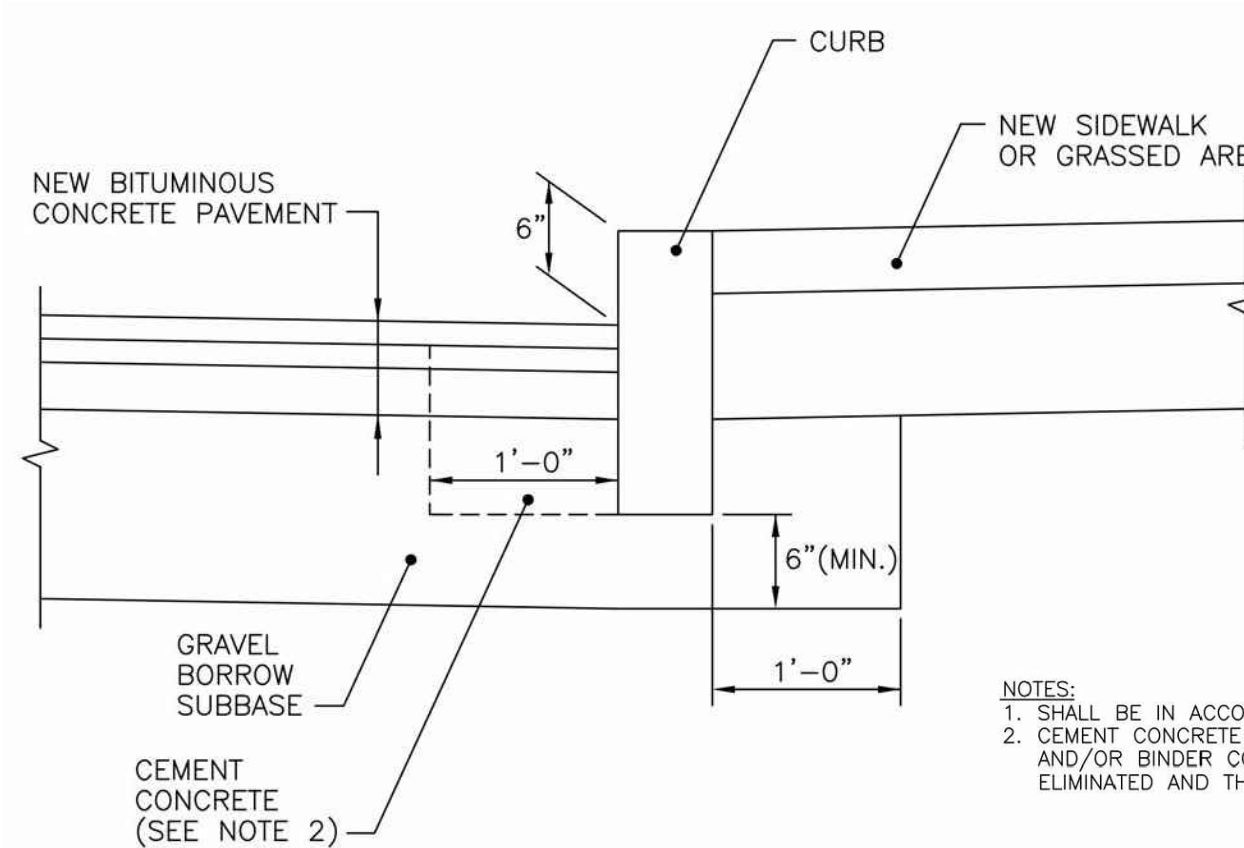

NOTES:

1. SHALL BE IN ACCORDANCE WITH SECTION 906 OF THE R.I. STANDARD SPECIFICATIONS.
2. CEMENT CONCRETE SHALL BE USED ONLY WHEN THE CURB IS SET AFTER THE BASE AND/OR BINDER COURSES ARE IN PLACE, OTHERWISE THE CEMENT CONCRETE WILL BE ELIMINATED AND THE GRAVEL BROUGHT UP TO BOTTOM OF THE BASE COURSE.

Curb Setting Detail

NOT TO SCALE

DiPrete Engineering
Two Stafford Court Cranston, RI 02920
tel: 401-943-1000 fax: 401-641-6006 www.diprete-eng.com

Boston • Providence • Newport

KEVIN DEMERS
REGISTERED PROFESSIONAL ENGINEER CIVIL

LOCATION MAP N.T.S.

This regulatory submission set shall not be used for construction purposes unless stamped 'Issued for Construction' and signed by a DiPrete Engineering representative.

The contractor is responsible for all of the means, methods, safety precautions and requirements, and OSHA conformance in the implementation of this plan and design.

NO.	DATE	DESCRIPTION	BY
2	10/29/2020	Preliminary Revisions	IMF
1	9/24/2020	Preliminary Revisions	IMF
0	7/30/2020	Plain Paper BIM Williams Submission	IMF

Drawn By: IMF
Design By: C.H.D.

Detail Sheet - 3

The Village at Curtis Corner

Assessor's Plat 40-1, 40-2, 40-3
South Kingston, Rhode Island

5A Builders, LLC
220 Knowlesway Extension
Narragansett, RI 02882

DE Job No: 0265-053 Copyright: 2017 by DiPrete Engineering Associates, Inc.

SHEET **15** OF 17

Z:\Main\projects\0265-053 curts corner road 109\unocad drawings\0265-053-cur.dwg Plotted: 10/29/2020

Curve Table

CURVE	LENGTH	DELTA	RADIUS	TANGENT	CHORD LENGTH	CHORD BEARING
C1	40.56'	16°35'56"	140.00'	20.42'	40.42'	S15°13'56"E
C2	102.61'	106°53'38"	55.00'	74.18'	88.36'	S60°22'47"E
C3	15.03'	57°25'16"	15.00'	8.22'	14.41'	N37°27'46"E
C4	8.64'	9°54'13"	50.00'	4.33'	8.63'	N13°42'15"E
C5	65.51'	75°04'02"	50.00'	38.41'	60.92'	N56°11'22"E
C6	32.68'	37°26'35"	50.00'	16.95'	32.10'	S67°33'20"E
C7	32.51'	37°15'24"	50.00'	16.85'	31.94'	S30°12'20"E
C8	40.22'	46°05'04"	50.00'	21.27'	39.14'	S11°27'54"W
C9	45.00'	51°33'58"	50.00'	24.15'	43.50'	S60°17'25"W
C10	32.74'	37°31'15"	50.00'	16.98'	32.16'	N75°09'58"W
C11	15.03'	57°25'16"	15.00'	8.22'	14.41'	N85°06'58"W
C12	15.46'	9°19'18"	95.00'	7.75'	15.44'	S70°50'03"W
C13	40.66'	24°31'23"	95.00'	20.65'	40.35'	S87°45'24"W
C14	20.00'	12°03'44"	95.00'	10.04'	19.96'	N73°57'02"W
C15	20.00'	12°03'44"	95.00'	10.04'	19.96'	N61°53'18"W
C16	20.00'	12°03'44"	95.00'	10.04'	19.96'	N49°49'34"W
C17	29.46'	17°45'53"	95.00'	14.85'	29.34'	N34°54'46"W
C18	31.66'	19°05'50"	95.00'	15.98'	31.52'	N16°28'54"W
C19	28.97'	16°35'56"	100.00'	14.59'	28.87'	N15°13'56"W
C20	257.30'	294°50'31"	50.00'	31.95'	53.85'	S23°49'36"E
C21	177.24'	106°53'38"	95.00'	128.14'	152.63'	N60°22'47"W
C22	10.70'	12°15'31"	50.00'	5.37'	10.68'	S5°26'53"E
C23	10.13'	11°36'32"	50.00'	5.08'	10.11'	S17°22'54"E

Open Space 100
990,757 SF
22.74 Acres

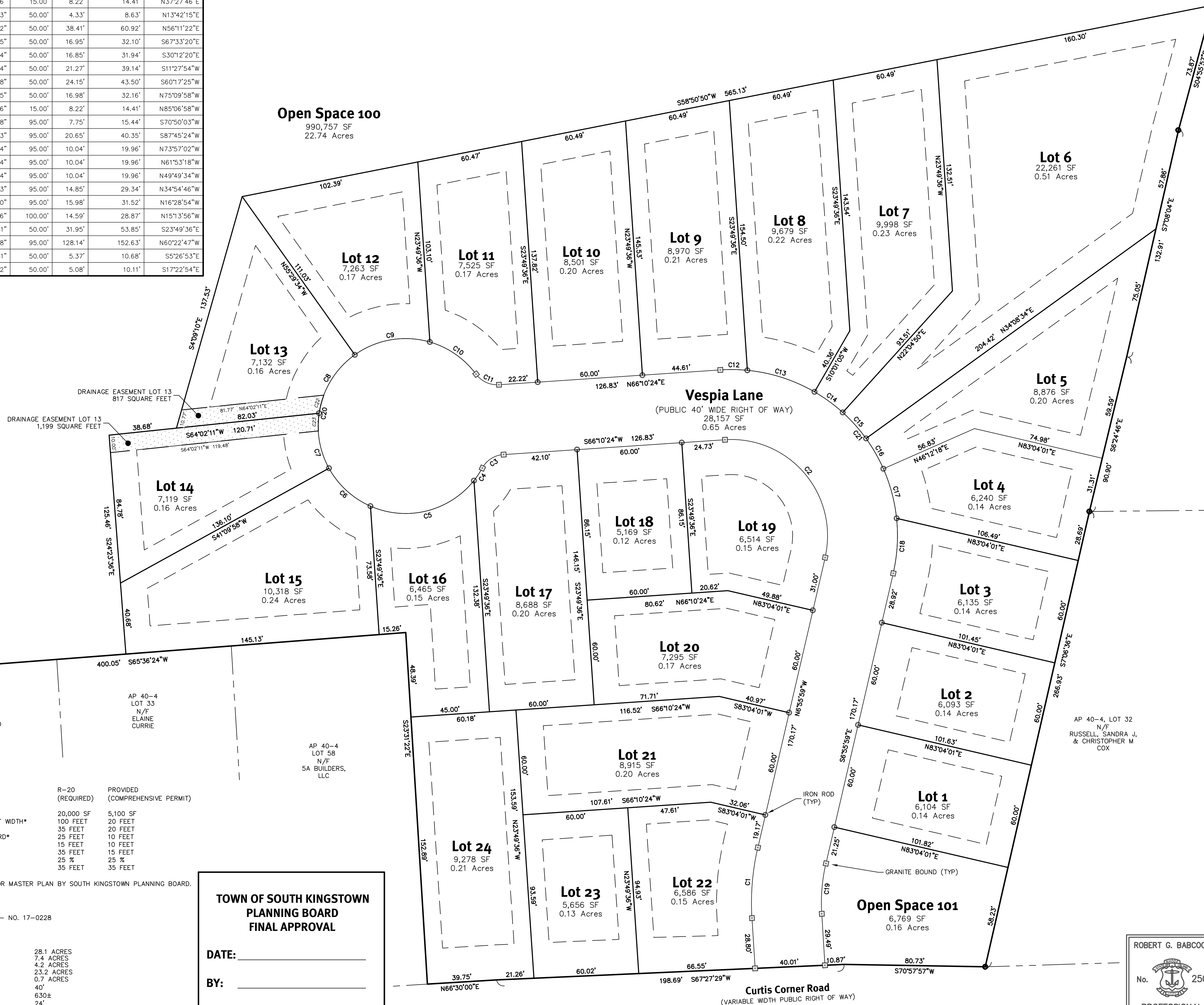

Master Plan - Conditions of Approval - Dated 3/3/20:

- APPROVAL IS LIMITED TO TWENTY-FOUR (24) LOTS CONTAINING SIXTEEN (16) SINGLE-FAMILY HOMES AND EIGHT (8) DUPLEX DWELLINGS AND TOTALING THIRTY-TWO (32) DWELLING UNITS.
- THE USE OF THE PROPOSED LOTS SHALL BE LIMITED AS FOLLOWS:
A. LOTS 1-4, 8-9, 12-13, 15-19, AND 22-24 SHALL BE DEVELOPABLE LOTS EACH TO CONTAIN SINGLE-FAMILY DETACHED STRUCTURES (USE CODE 10).
B. LOTS 5-7, 10-11, 14, AND 20-21 SHALL BE DEVELOPABLE LOTS EACH TO CONTAIN A TWO HOUSEHOLD DETACHED STRUCTURE OR DUPLEX (USE CODE 11).
- APPROVAL IS BASED UPON THE PROVISION OF 25% SUBSIDIZED HOUSING UNITS AVAILABLE FOR LOW AND MODERATE INCOME RESIDENTS. THE LOW AND MODERATE INCOME DWELLING UNITS WILL BE SOLD OR LEASED TO A PERSON OR FAMILY WITH AN INCOME AT OR BELOW 80% OF THE AREA MEDIAN INCOME AND BE DEED RESTRICTED FOR A PERIOD OF 99 YEARS.
- PROPOSED LMI HOUSING UNITS SHALL BE INTEGRATED THROUGHOUT THE DEVELOPMENT, SHALL BE COMPATIBLE IN SCALE AND ARCHITECTURAL STYLE TO THE MARKET RATE UNITS WITHIN THE PROJECT, AND THEY SHALL BE BUILT AND OFFERED FOR OCCUPANCY SIMULTANEOUSLY WITH THE CONSTRUCTION AND OCCUPANCY OF THE MARKET RATE UNITS.
- AS PART OF THE PRELIMINARY PLAN SUBMITTAL, THE APPLICANT SHALL INDICATE WHICH SPECIFIC LOTS AND/OR UNITS WILL CONTAIN THE LMI HOUSING UNITS AND SHALL PROPOSE THE SCHEDULE BY WHICH THE LMI HOUSING UNITS WILL BE CONSTRUCTED, SAID SCHEDULE SHALL NOT EXCEED THE CONSTRUCTION OF THREE (3) MARKET-RATE UNITS FOR EVERY ONE (1) LMI HOUSING UNIT.
- AS PART OF THE PRELIMINARY PLAN SUBMITTAL, THE APPLICANT SHALL INCLUDE A LETTER OF ELIGIBILITY FROM RHODE ISLAND HOUSING FOR THE PROJECT AS PROPOSED.
- AS PART OF THE PRELIMINARY PLAN SUBMITTAL, THE APPLICANT SHALL PROVIDE DRAFTS OF A "MONITORING AGREEMENT" AND A "DEED RESTRICTION" THAT WILL ENSURE THAT AFFORDABILITY GUIDELINES WILL BE MET. SUCH DOCUMENTS SHALL BE SUBJECT TO THE REVIEW AND APPROVAL OF THE TOWN'S SPECIAL LEGAL COUNSEL AND THE PLANNING BOARD.
- THE MONITORING AGREEMENT BETWEEN THE DEVELOPER AND THE MONITORING AGENT SHALL REQUIRE NOTIFICATION TO THE TOWN OF SOUTH KINGSTOWN, AS A PARTY WITH A VESTED INTEREST, OF THE AVAILABILITY OF AFFORDABLE HOUSING UNITS FOR PURCHASE OR LEASE. ANY SUCH NOTIFICATION SHALL BE DIRECTED TO THE DIRECTOR OF PLANNING.
- THE APPLICANT SHALL SUBMIT A DOWNSTREAM CARRYING CAPACITY ANALYSIS TO THE DEPARTMENT OF PUBLIC SERVICES FOR REVIEW AND APPROVAL PRIOR TO SUBMITTAL OF THE PRELIMINARY PLAN APPLICATION. APPROVAL OF THE SEWER CONNECTION FROM THE DEPARTMENT OF PUBLIC SERVICES SHALL BE INCLUDED WITH THE PRELIMINARY PLAN AT THE TIME OF APPLICATION SUBMITTAL.
- THE APPLICANT SHALL RESEARCH WALKING PATH(S) CONNECTING THE PROPOSED DEVELOPMENT TO ROUTE 108 AND PRESENT FINDINGS IN AT THE PRELIMINARY STAGE OF REVIEW.
- EXHIBIT A SHALL BE CORRECTED AND SUBMITTED AT PRELIMINARY (FIRST PAGE & PARAGRAPH) TO INDICATE THAT THE R20 ZONING DISTRICT REQUIREMENTS WOULD PERMIT 14 DWELLING UNITS (NOT IN ACCORDANCE WITH THE YIELD PLAN PROVIDED WITH THE APPLICATION AND THAT THE APPLICANT SHOULD CLARIFY WHAT THE REQUESTED MODIFICATION OF THE DIMENSIONAL REQUIREMENTS FROM 100' TO 20' OF FRONTAGE APPLIES TO.

Dimensional Regulations:

	R-20 (REQUIRED)	PROVIDED (COMPREHENSIVE PERMIT)
MINIMUM LOT AREA*	20,000 SF	5,100 SF
MINIMUM FRONTAGE AND LOT WIDTH*	100 FEET	20 FEET
MINIMUM FRONT YARD*	35 FEET	20 FEET
MINIMUM FRONT CORNER YARD*	25 FEET	10 FEET
MINIMUM SIDE YARD*	15 FEET	10 FEET
MINIMUM REAR YARD*	35 FEET	15 FEET
MAXIMUM LOT COVERAGE	25 %	25 %
MAXIMUM HEIGHT	35 FEET	35 FEET

*RELIEF GRANTED ON 3/11/2020 FOR MASTER PLAN BY SOUTH KINGSTOWN PLANNING BOARD.

State Permits Received

RIDEM INSIGNIFICANT ALTERATION - NO. 17-0228

Development Data :

TOTAL SITE AREA:	28.1 ACRES
TOTAL SUITABLE LOT AREA:	7.4 ACRES
TOTAL LOT AREA:	4.2 ACRES
TOTAL OPEN SPACE AREA:	23.2 ACRES
TOTAL RIGHT OF WAY AREA:	0.7 ACRES
RIGHT OF WAY WIDTH:	40'
LENGTH OF ROAD:	630±
ROAD WIDTH:	24'
SIDEWALK WIDTH:	4'
TOTAL NUMBER OF LOTS:	24
TOTAL NUMBER OF UNITS:	32 (8 DUPLEX + 16 SINGLE-FAMILY)
TOTAL NUMBER OF AFFORDABLE UNITS:	8 (25% OF TOTAL UNITS)

*RELIEF GRANTED ON 3/11/2020 FOR MASTER PLAN BY SOUTH KINGSTOWN PLANNING BOARD.

**TOWN OF SOUTH KINGSTOWN
PLANNING BOARD
FINAL APPROVAL**

DATE: _____

BY: _____

**This Plan Should Be Indexed By
The Following Streets:**

- Curtis Corner Road

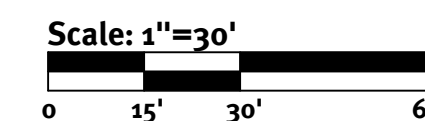
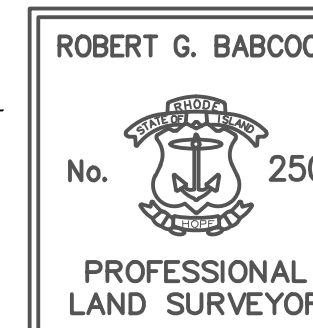

Robert G. Babcock
ROBERT G. BABCOCK, RIPLS #2504, COA #LS.000A160
1/18/20

Record Plan
The Village at Curtis Corner
South Kingstown, Rhode Island

5A Builders, LLC
15 Robertson Road
Narragansett, RI 02882

NO.	DATE	DESCRIPTION	BY
0	3/1/20	Record Plan	ELI

c:\deman\projects\0385-053\curtis corner road\03\unacad.dwg (03/05/2020) dwg Plotter: 10/29/2020