

South Kingstown, Rhode Island  
Proposed Residential Development

*August 2023*

TRAFFIC IMPACT STUDY

---



**BETA**

701 George Washington Hwy  
Lincoln, Rhode Island 02865  
401.333.2382  
[www.BETA-inc.com](http://www.BETA-inc.com)

# Proposed Residential Development Village at Broad Rock

South Kingstown, Rhode Island

## TRAFFIC IMPACT STUDY

---

Prepared by: BETA GROUP, INC.

Prepared for: Mr. Steve Clarke  
New England Properties, LLC  
257 Wickford Court  
North Kingstown, RI 02852

August 2023



August 25, 2023

Mr. Steve Clarke  
New England Properties, LLC  
257 Wickford Court  
North Kingstown, RI 02852

Re: Proposed Residential Development  
*Village at Broad Rock*  
South Kingstown, Rhode Island

Dear Mr. Clarke:

BETA Group, Inc., in accordance with our scope of services, has completed a traffic impact study for a proposed residential development project in the Town of South Kingstown, Rhode Island. The site is located along the westerly side of Broad Rock Road approximately 2,400 feet north of Saugatucket Road. The parcel contains approximately 16.5 acres of partially developed land.

Based upon our discussions and a review of the site development plan provided by *Commonwealth Engineers and Consultants, Inc.*, it is our understanding that the residential project includes construction of 19 single family homes within a new cul-de-sac neighborhood. Access and egress to the residential subdivision is proposed from a new local road intersecting with Broad Rock Road.

The study included herein, was conducted to determine the adequacy of the existing servicing roadways to accommodate anticipated traffic to be generated by the residential development project. An analysis of potential impacts to the roadway capacity and safety has been completed and is discussed in the following report.

Very truly yours,  
BETA Group, Inc.

A handwritten signature in black ink, appearing to read "Paul J. Bannon", is written over a large, light gray, stylized leaf or petal graphic that is part of the BETA logo.

Paul J. Bannon  
Associate

## TABLE OF CONTENTS

1.0 Introduction .....	1
2.0 Project Area.....	3
3.0 Existing Conditions.....	3
3.1 Roadways.....	3
3.2 Intersections.....	5
3.3 Traffic Data.....	5
4.0 Safety Analysis.....	6
5.0 Impact Analysis.....	8
5.1 Trip Generation .....	8
5.2 Future Traffic Conditions .....	10
5.3 Operational Analysis.....	12
6.0 Conclusions and Recommendations.....	14

## APPENDICES

- Appendix A: Traffic Volume Data
- Appendix B: Traffic Crash Data
- Appendix C: Trip Generation
- Appendix D: Operational Analysis

## LIST OF TABLES

TABLE 1 – Crash Data Summary .....	8
TABLE 2 – Trip Generation Estimate.....	10
TABLE 3 – Highway Capacity Manual Criteria .....	12
TABLE 4 – Level of Service Summary (Existing Conditions) .....	13
TABLE 5 – Level of Service Summary (No-Build Conditions).....	13
TABLE 6 – Level of Service Summary (Build Conditions) .....	14

## LIST OF FIGURES

FIGURE 1 – Project Vicinity Map .....	2
FIGURE 2 – Project Location Map.....	4
FIGURE 3 – Existing Traffic Volumes.....	7
FIGURE 4 – Site Layout and Access Plan .....	9
FIGURE 5 – Future Traffic Volumes .....	11

## 1.0 INTRODUCTION

The objective of the following study is to assess the potential traffic impacts associated with a proposed residential development in the Town of South Kingstown, Rhode Island. The residential project is proposed on a partially developed lot on the westerly side of Broad Rock Road, between Saugatucket Road and Mooresfield Road (Route 138), shown in Figure 1 on the following page.

The proposed residential development consists of the subdivision of Assessors Plat 33, Lot 24 containing 16.5 acres of land into 19 lots for the construction of single-family homes. A separate dedicated 9.35 acres will be preserved as open space. Access/egress to the residential neighborhood will be provided from a new cul-de-sac subdivision road intersecting with Broad Rock Road.

The study summarized herein focused on both traffic flow efficiency and safety along Broad Rock Road and Saugatucket Road in the immediate vicinity of the subject property, including the proposed site access road. The potential impacts associated with the site related traffic have been defined and evaluated in accordance with standard traffic engineering guidelines and procedures.

The traffic engineering study completed for this project included the following:

- A traffic counting program to define the existing traffic patterns and operational characteristics along the servicing roadways. The data collection included an Automatic Traffic Recorder (ATR) count on Broad Rock Road in the immediate site vicinity, a manual Turning Movement Count (TMC) at the intersection of Broad Rock Road with Saugatucket Road, and a review of record count data from the Rhode Island Department of Transportation (RIDOT) in the project vicinity.
- An inventory of the physical roadway characteristics of Broad Rock Road and Saugatucket Road to determine the adequacy of the existing roadway geometric features in reference to safety and operations.
- An analysis of crash records obtained from the South Kingstown Police Department to determine if there are any safety concerns relative to the frequency, severity, or pattern of crashes in the project area.
- An estimate of future traffic volumes for the proposed residential development was calculated using data from the *Trip Generation Manual*, an informational report published by the Institute of Transportation Engineers (ITE).
- Evaluation and analysis of the traffic safety and operations for existing and future traffic conditions and development of recommendations where necessary, that would be required to maintain safe and efficient traffic flow in the project area.

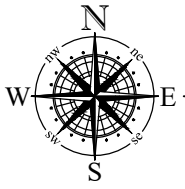

# Village at Broad Rock

SOUTH KINGSTOWN, RHODE ISLAND

## Figure 1 - Project Vicinity Map

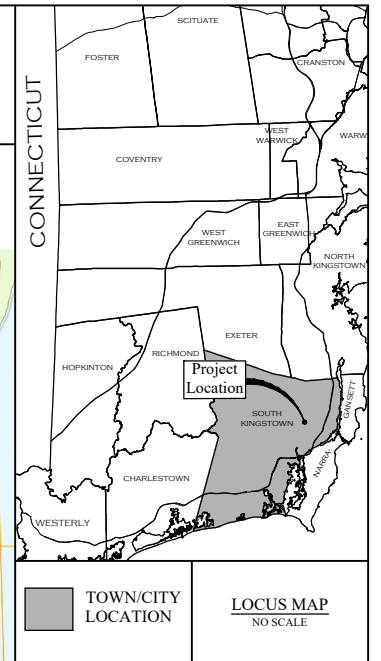
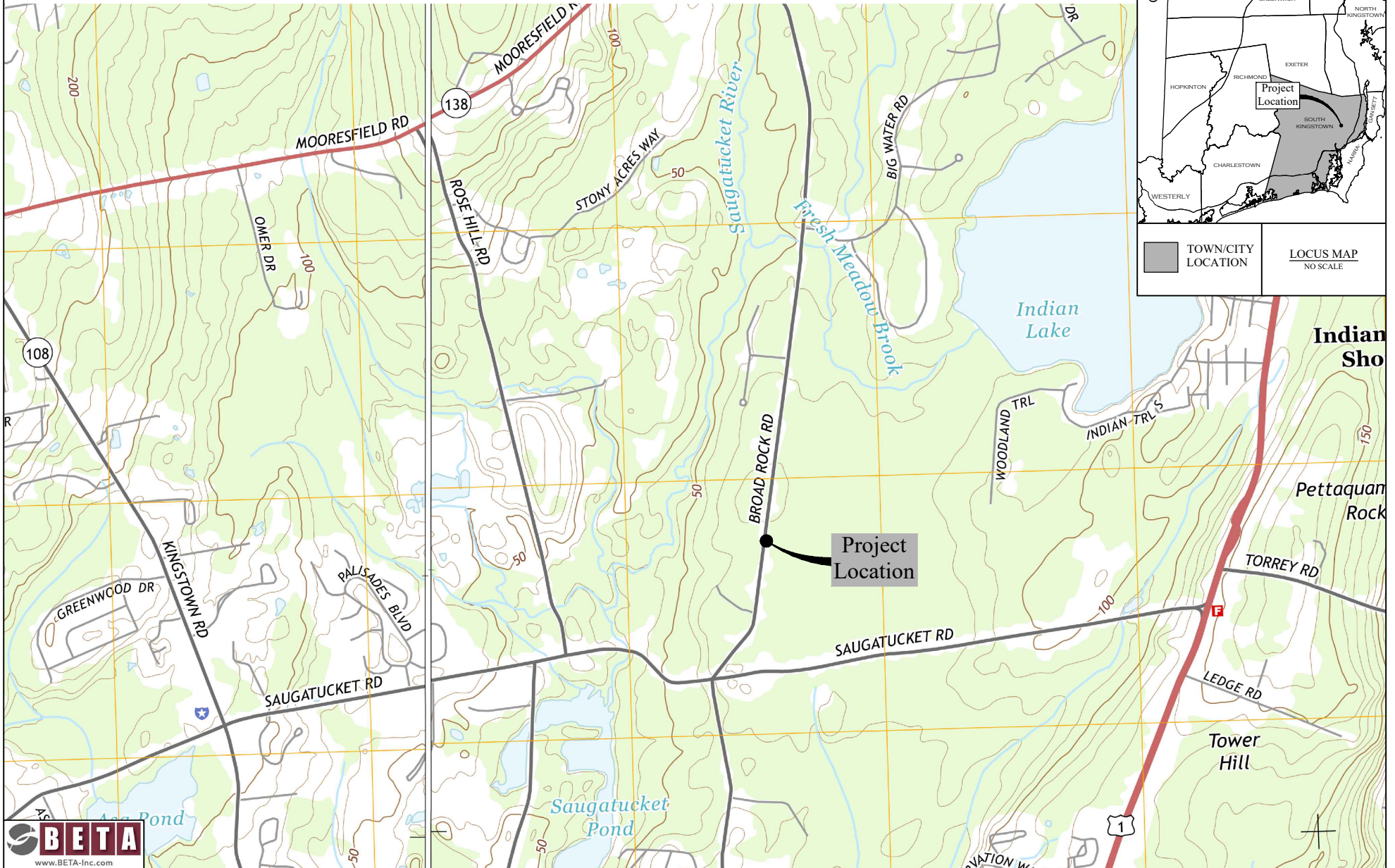

## 2.0 PROJECT AREA

As noted in the previous section, the proposed residential project is situated on a parcel of land along the westerly side of Broad Rock Road, approximately 2,400 feet north of the intersection with Saugatucket Road. The subject parcel contains approximately 16.5 acres of partially developed land that includes a home and several structures. Figure 2 on the following page depicts the general project area, and the boundary lines of the subject property.

Land use in the immediate area can be defined as predominantly residential surrounding the subject property and along Broad Rock Road between Saugatucket Road and Mooresfield Road (Route 138). The Saugatucket River abuts the property to the west. The University of Rhode Island South Kingstown campus is located approximately four miles to the northwest. Major routes are available in the immediate area including Rhode Island State Highway Route 108 (Kingstown Road) approximately one mile west from the intersection of Broad Rock Road with Saugatucket Road, and US Route 1 (Tower Hill Road) approximately 1.2 miles east of the intersection.

Broad Rock Road will serve as the primary access route to the new neighborhood. Based upon the good operating characteristics along the servicing roadways in the immediate site vicinity, and the small scale of the proposed development land use, a study impact area was defined. The limits of the study for analysis focused on Broad Rock Road between the proposed site access road and Saugatucket Road, including their intersections.

## 3.0 EXISTING CONDITIONS

### 3.1 ROADWAYS

#### Broad Rock Road

Broad Rock Road is a north/south urban major collector between Saugatucket Road to the south and Mooresfield Road (Route 138) to the north. Broad Rock Road is primarily used by drivers for immediate property access along the road, while also used to access some of the busier, higher order roadways in South Kingstown as noted. In the project area, Broad Rock Road is approximately 24-feet wide consisting of a 12-foot travel in each direction delineated by a double yellow centerline. These features can be seen in the adjacent photograph. The pavement surface can be classified as being in good condition along the property



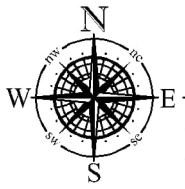

# Village at Broad Rock

SOUTH KINGSTOWN, RHODE ISLAND

## Figure 2 - Project Area Map

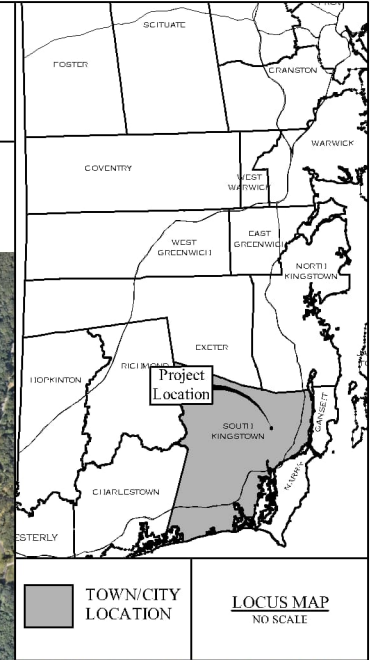

frontage. The posted speed limit is 25 mph in the site vicinity. There is no curbing provided along the roadway maintaining its rural residential character. In addition, lighting is available sporadically on utility poles for nighttime illumination of the roadway.

### Saugatucket Road

Saugatucket Road is an east/west urban major collector extending between Tower Hill Road and Kingstown Road. The roadway width varies but is generally 26 feet wide consisting of a 13-foot travel lane in each direction, as seen in the adjacent photograph (traveling east).



There are sections of asphalt berm located sporadically along the northern and southern sides of the road. The pavement can be classified as being in good to fair condition with minor crack sealing treatments. The posted speed limit is 35 mph. Lighting via cobra head fixtures on utility poles is provided sporadically for night time visibility in the area.

## 3.2 INTERSECTIONS

### Broad Rock Road at Saugatucket Road

Broad Rock Road intersects Saugatucket Road to form an unsignalized, four-way junction. The intersection is stop controlled on all approaches. Saugatucket Road makes up the eastern and western legs of the intersection, while Broad Rock Road makes up the northern and southern legs. Each leg of the intersection is comprised of one lane for all movements, with the exception of the eastern leg of Saugatucket Road, which provides a channelized right turn under yield control. No sidewalks or crosswalks are present at the intersection.



## 3.3 TRAFFIC DATA

Existing traffic flow characteristics for this area were developed from a traffic counting program conducted by BETA and through review of historical data available from the RIDOT. In April 2023, the data collection included a seven-day Automatic Traffic Recorder (ATR) count on Broad Rock Road along the

property frontage. Additionally, a manual Turning Movement Count (TMC) was conducted at the unsignalized intersection of Broad Rock Road with Saugatucket Road during the weekday morning and afternoon peak periods between 7:00 AM to 9:00 AM and 4:00 PM to 6:00 PM, respectively.

Based upon the April 2023 ATR data, Broad Rock Road along the property frontage was found to service approximately 1,400 vehicles per day (VPD) with morning and afternoon peak hour volumes of approximately 130 vehicles per hour serviced during both periods. This daily volume is consistent with record RIDOT information further north in the vicinity of Route 138.

Based upon the turning movement data obtained at the study intersection of Broad Rock Road with Saugatucket Road, the morning peak hour of traffic was determined to be between 7:00 and 8:00 AM where approximately 155 vehicles (65 SB/90 NB) are serviced on Broad Rock Road. During the weekday afternoon peak hour between 4:30 and 5:30 PM, Broad Rock Road north of Saugatucket Road was found to service 215 vehicles with approximately 100 vehicles northbound and 115 vehicles southbound. Figure 3 on the following page depicts the daily peak hour turning movement volumes at the study intersection utilized in our analysis. Complete count information can be found in the Appendix.

## 4.0 SAFETY ANALYSIS

To determine if there are any limiting factors affecting safety relating to access to the proposed residential project, the physical characteristics of Broad Rock Road and Saugatucket Road in the project area were investigated. These limiting factors would potentially include horizontal or vertical roadway geometry changes or roadside obstructions that limit sight distances for vehicles traveling along the road or entering the road from a side street or driveway location. In this instance, the sight distance standard is necessary to permit turning vehicles to safely enter and exit the proposed site access road.

In addition to reviewing geometric roadway conditions, speed data was also obtained to determine the 85<sup>th</sup> percentile speed for drivers within the project area. The 85<sup>th</sup> percentile speed is considered as a *design speed* and represents the speed at which 85 percent of drivers are travelling at or slower and is utilized in the analysis of required sight distances. The most recent edition of the American Association of State Highway and Transportation Officials' (AASHTO's) publication *A Policy on Geometric Design of Highways and Streets* is referenced for required stopping sight distances based on the design speeds for each roadway. The stopping sight distance is the minimum distance that a vehicle driving along the roadway requires in order to adequately react and safely come to a stop to avoid a collision.

The horizontal and vertical curvature of Broad Rock Road in the project area can be described as straight and level. Based upon the existing roadway geometry as defined, the measured sight distances along Broad Rock Road at the proposed site access road junction are greater than 500 feet to the north and south. These values are greater than AAASHTO's recommended minimum sight distance of 155 feet for the posted speed limit of 25 mph and the 260 feet based on the 85<sup>th</sup> percentile vehicle speeds of 36 mph measured on Broad Rock Road.

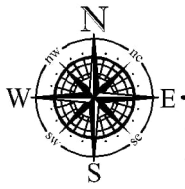

# Village at Broad Rock

SOUTH KINGSTOWN, RHODE ISLAND

## Figure 3 - Existing Traffic Volumes



### 1 Broad Rock Road at Saugatucket Road

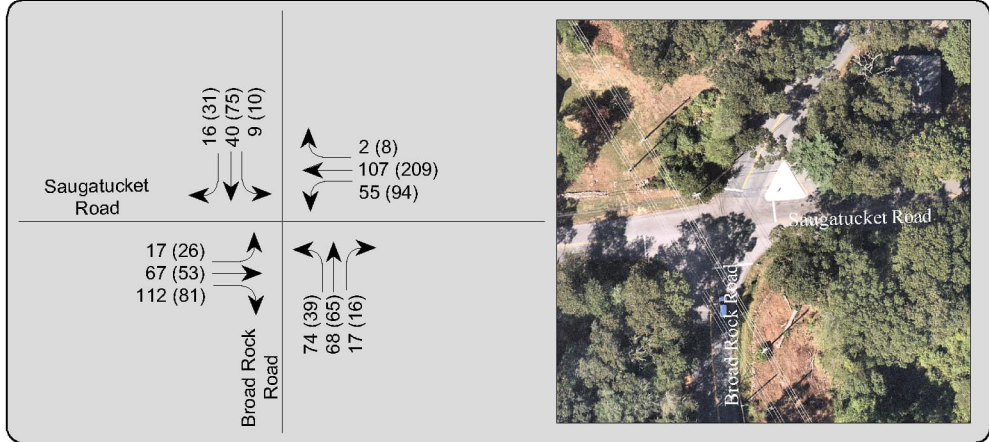

**LEGEND:**

- TURN LANE
- XXX AM PEAK VOLUMES (7:00 TO 8:00)
- (XXX) PM PEAK VOLUMES (4:30 TO 5:30)
- STUDY INTERSECTION

Also, as part of the safety analysis, a review of crash statistics was completed along Broad Rock Road and Saugatucket Road within the study area. Data was reviewed from the Town of South Kingstown Police Department for the latest full three-year period (2017-2019) to determine if any location in the immediate vicinity of the development experienced a high frequency or pattern of crashes. Due to the COVID-19 pandemic, the 2020 and 2021 data were not requested as traffic patterns and volumes were notably impacted and not representative of average traffic conditions.

A total of two crashes occurred in the project area over the three-year study period, with no reported injuries and no fatalities. Table 1 below summarizes the crash data, all of which occurred at the intersection of Broad Rock Road with Saugatucket Road.

TABLE 1 – Crash Data Summary

	Year			Total	Average per Year
	2017	2018	2019		
Intersections					
Broad Rock Road at Saugatucket Road	0	2	0	2	<1

Both crashes at the unsignalized intersection of Broad Rock Road at Saugatucket Road were angled collisions. One was due to a driver not stopping completely at a stop sign and very slowly striking a person on a bicycle. The other collision was caused by a driver pulling forward and not seeing the other driver proceeding forward. This low crash total leads to less than one crash per year which is indicative of an intersection operating safely, especially considering the junction in question involves two major collector roads. Based upon the historical crash data obtained from the local police, and a review of existing roadway geometry and operations, roadway or traffic related safety enhancements are not warranted.

## 5.0 IMPACT ANALYSIS

### 5.1 TRIP GENERATION

To determine the traffic impact of a proposed development, estimates of anticipated traffic to be generated by a particular land use must be calculated. As previously discussed, the proposed development consists of the construction of 19 single family homes in a typical residential subdivision. Access/egress to the residential neighborhood will be provided from a new intersection on Broad Rock Road extending as a local a cul-de-sac street serving individual driveways. Figure 4 on the following page depicts the site layout and access plan provided by *Commonwealth Engineers and Consultants, Inc.*

For this development, estimated traffic volumes for the residential project were based on use of trip generation data obtained from the *Trip Generation Manual*, an informational report published by the Institute of Transportation Engineers (ITE), a national professional organization for traffic and transportation engineers. The data provided in the ITE report are based on extensive traffic studies for

# Village at Broad Rock

SOUTH KINGSTOWN, RHODE ISLAND

## Figure 4 - Site Layout

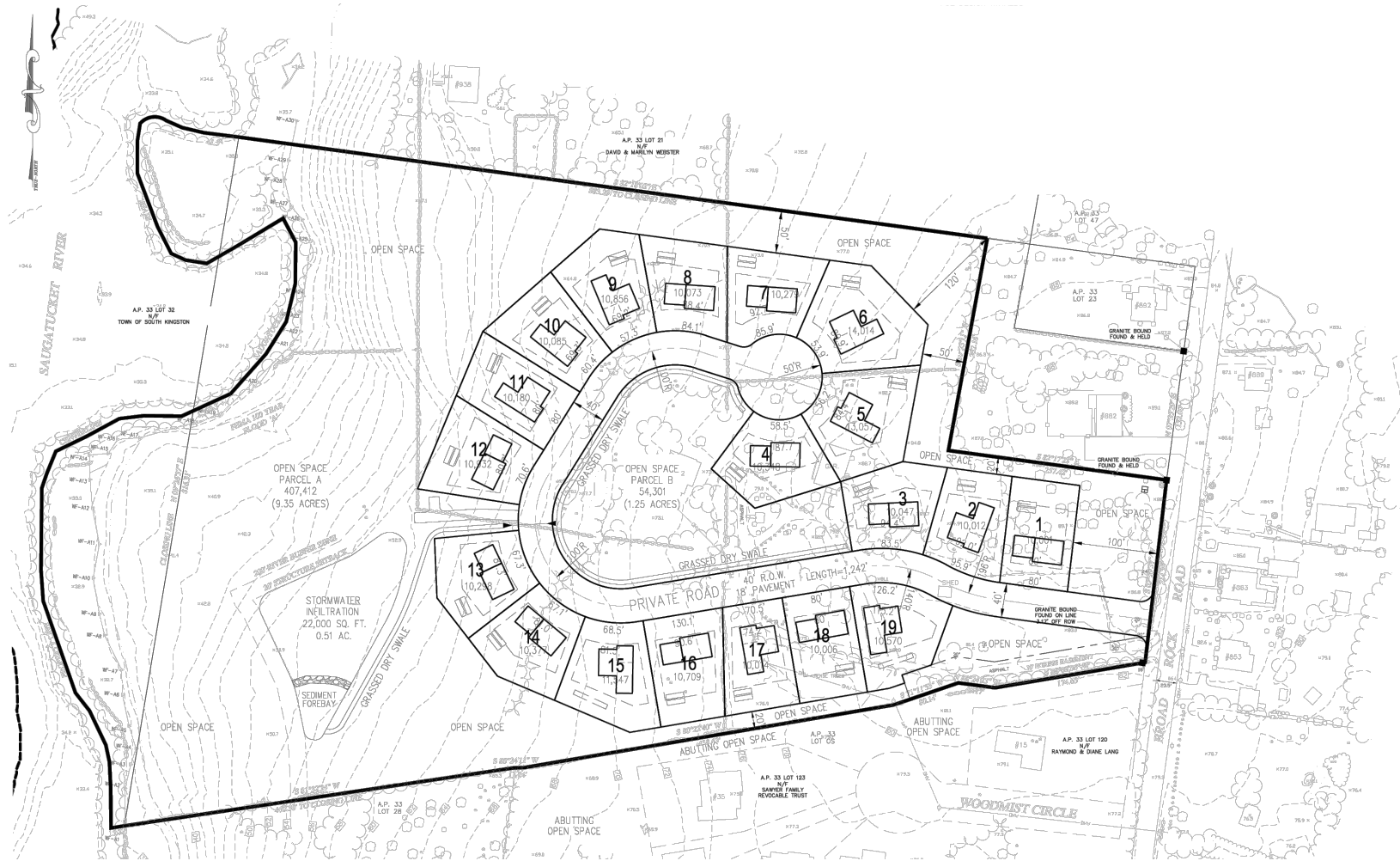

Site Plan provided by Commonwealth Engineers and Consultants, Inc.

numerous types of land uses (residential, commercial, industrial, etc.). This data has been found to be very reliable and provides a sound basis for estimating future trips to new development projects.

For the proposed residential project, Land Use Code (LUC) 210 Single-Family Detached Housing was reviewed for applicability in developing an estimate of site related vehicles trips. Table 2 summarizes the peak hour site trips for the residential project that have been estimated utilizing the land use code data available from the *Trip Generation Manual*. The appropriate worksheets from the manual are included in the Appendix, along with the trip estimate calculations.

TABLE 2 – Trip Generation Estimate

<u>Description</u>		<u>Enter</u>	<u>Exit</u>	<u>Total</u>
<u>Weekday AM Peak Hour</u>				
ITE Land Use Code 210	Single-Family Detached Housing	4	9	13
<u>Weekday PM Peak Hour</u>				
ITE Land Use Code 210	Single-Family Detached Housing	11	7	18

## 5.2 FUTURE TRAFFIC CONDITIONS

In order to properly assess the traffic impacts from a development, future traffic conditions of area roadways should be estimated for the period when the development is constructed and fully occupied. Typically, the expansion of base traffic is calculated when a project is to be constructed over an extended period, typically five years. The Town of South Kingstown has seen a minimal population increase of approximately 0.004 percent over the past decade. To be conservative for our study this was increased to a half percent. The half percent rate was applied to the existing volumes to establish a Future 2028 No-Build condition on the servicing roadways.

The No-Build condition is a combination of these future volumes with other approved developments to be built by 2028, whose traffic is anticipated to exist within the study area. The only outside development that was considered based upon coordination with the town, is the *Village at Curtis Corner* off of Saugatucket Road, which is a small scale residential development consisting of 32 condominium dwelling units. The peak hour volumes generated by this development and distributed to the study area, were determined to be insignificant and therefore considered to be captured by the general background growth rate applied to the existing volumes.

The proposed residential development was then added to the No-Build condition to establish the Future 2028 Build traffic condition. Figure 5 on the following page depicts the estimated future traffic volumes at the study intersections.

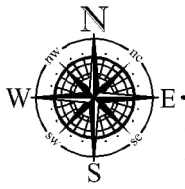

# Village at Broad Rock

SOUTH KINGSTOWN, RHODE ISLAND

## Figure 5 - Proposed Traffic Volumes



### 1 Broad Rock Road at Saugatucket Road



### 2 Broad Rock Road at Site Driveway

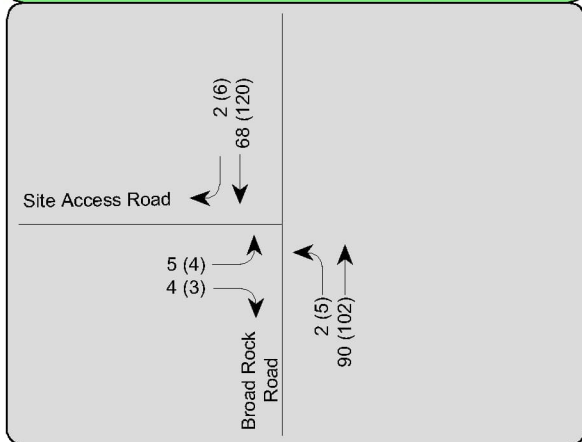

**LEGEND:**

- TURN LANE
- XXX AM PEAK VOLUMES (7:00 TO 8:00)
- (XXX) PM PEAK VOLUMES (4:30 TO 5:30)
- STUDY INTERSECTION

In developing the intersection volumes to be analyzed under build conditions, a directional distribution of the site traffic was estimated. The distribution was based on current traffic patterns in the area. It is estimated that 55% of the site trips will arrive from and depart to the north and 45% will arrive and depart to the south. Traffic from the development directed to the intersection of Broad Rock Road at Saugatucket Road were estimated to be distributed similar to existing traffic patterns at the junction.

### 5.3 OPERATIONAL ANALYSIS

The key to any traffic impact analysis is the evaluation of roadway operations during peak traffic periods on the servicing roadway system. This condition would occur when the site-generated traffic, combined with the traffic volumes on the main roadway, result in the highest one-hour volume serviced along a roadway segment, or through an intersection. Review of record traffic data found that the weekday morning and afternoon peak hours would represent this worst-case combination of site-generated traffic with the servicing roadway peak traffic period.

The Highway Capacity Manual methodologies provide the most accurate means of evaluating traffic capacity and delays for roadways and intersections. The results of this procedure are expressed in terms of Level of Service (LOS). Level of Service is a qualitative measure of traffic flow efficiency based on anticipated vehicle delays. For example, LOS "A" represents the best condition with little or no delay, while LOS "F" indicates that the roadway/intersection is at full capacity resulting in extended vehicle delays and potential queuing. Table 3 outlines the Level of Service delay criteria presented in the Highway Capacity Manual for signalized and unsignalized intersections.

TABLE 3 – Highway Capacity Manual Criteria

<u>Level of Service</u>	<u>Unsignalized Delay Per Vehicle (sec)</u>	<u>Signalized Delay Per Vehicle (sec)</u>
A	<10	<10
B	>10 and <15	>10 and <20
C	>15 and <25	>20 and <35
D	>25 and <35	>35 and <55
E	>35 and <50	>55 and <80
F	>50	>80

The study area intersections were all analyzed for the weekday morning and afternoon peak hours. The capacity analysis worksheets are included in the Appendix and Tables 4 through 6 summarize the results of the analyses.

Table 4 depicts the existing conditions at the study intersection of Broad Rock Road at Saugatucket Road. As can be seen in the table, the all-way stop controlled junction of Broad Rock Road with Saugatucket Road was determined to operate overall at an acceptable LOS B during the AM and PM peak hours, with critical movements experiencing LOS B or better.

TABLE 4 – Level of Service Summary (Existing Conditions)

Location / Movement	2022 EXISTING CONDITIONS							
	AM Peak Hour				PM Peak Hour			
	LOS	Delay	95 <sup>th</sup> % Queue Length (veh.)	v/c	LOS	Delay	95 <sup>th</sup> % Queue Length (veh.)	v/c
<i>Broad Rock Road at Saugatucket Road (U)</i>								
Broad Rock Road NB	B	10.4	2	0.30	A	9.8	1	0.20
Broad Rock Road SB	A	9.3	1	0.13	A	9.7	1	0.19
Saugatucket Road EB	A	9.9	2	0.33	A	9.4	1	0.24
Saugatucket Road WB	B	10.3	2	0.30	B	12.3	3	0.48
OVERALL	B	10.1	-	-	B	10.8	-	-

(U) – Unsignalized

Table 5 presents the Future 2028 No-Build design period taking into consideration the base traffic growth of 0.5 percent per year as previously noted. The proposed residential project is not included in this Future 2028 No-Build scenario. As can be seen in Table 5, under the Future 2028 No-Build conditions, the unsignalized intersection of Broad Rock Road with Saugatucket Road continues to operate overall at an acceptable LOS B during both the morning and afternoon peak traffic conditions, similar to existing conditions, with, again, all critical movements operating at LOS B during both peak hours.

TABLE 5 – Level of Service Summary (No-Build Conditions)

Location / Movement	2028 FUTURE NO BUILD CONDITIONS							
	AM Peak Hour				PM Peak Hour			
	LOS	Delay	95 <sup>th</sup> % Queue Length (veh.)	v/c	LOS	Delay	95 <sup>th</sup> % Queue Length (veh.)	v/c
<i>Broad Rock Road at Saugatucket Road (U)</i>								
Broad Rock Road NB	B	10.7	2	0.31	A	10.0	1	0.22
Broad Rock Road SB	A	9.5	1	0.14	A	9.9	1	0.21
Saugatucket Road EB	B	10.3	2	0.35	A	9.6	1	0.25
Saugatucket Road WB	B	10.6	2	0.32	B	13	3	0.50
OVERALL	B	10.4	-	-	B	11.2	-	-

(U) – Unsignalized

Table 6 represents the future design period taking into considerations base traffic growth along the servicing roadways, and the trips generated by the proposed residential project. As can be seen, the unsignalized intersection of Broad Rock Road with Saugatucket Road continues to operate overall at an acceptable LOS B during both the morning and afternoon peak traffic conditions, with critical movements also operating at LOS B or better.

The proposed unsignalized intersection of Broad Rock Road with the new site access road will also operate in an acceptable manner with critical movements operating at LOS A during the daily peak hours of traffic. These delays will also result in a maximum of only one vehicle queued on the minor approach residential street waiting to turn onto Broad Rock Road.

TABLE 6 – Level of Service Summary (Build Conditions)

Location / Movement	2028 FUTURE BUILD CONDITIONS							
	AM Peak Hour				PM Peak Hour			
	LOS	Delay	95 <sup>th</sup> % Queue Length (veh.)	v/c	LOS	Delay	95 <sup>th</sup> % Queue Length (veh.)	v/c
<i>Broad Rock Road at Saugatucket Road (U)</i>								
Broad Rock Road NB	B	10.8	2	0.32	B	10.1	1	0.22
Broad Rock Road SB	A	9.5	1	0.15	A	10.0	1	0.21
Saugatucket Road EB	B	10.3	2	0.35	A	9.7	1	0.26
Saugatucket Road WB	B	10.7	2	0.32	B	13.1	3	0.50
OVERALL	B	10.5	-	-	B	11.3	-	-
<i>Broad Rock Road at Site Access Road (U)</i>								
Broad Rock Road NB Left	A	7.4	0	0.00	A	7.5	0	0.00
Site Access Road WB All	A	9.1	1	0.01	A	9.5	0	0.01

(U) – Unsignalized

## 6.0 CONCLUSIONS AND RECOMMENDATIONS

In summary, the study has shown that the proposed residential development project access and circulation plan has been designed to provide a level of traffic safety and efficiency on the servicing roadway system. The safety of the Broad Rock Road study intersections including the proposed site access road were reviewed for geometry and sight distances. The site access road intersection was determined to provide sufficient sight distances in accordance with AASHTO criteria for visibility and decision making of drivers attempting to enter/exit main street traffic from the minor approach. Analysis of the crash data within the area revealed a low frequency of occurrence in crashes within the study area and no trends that may warrant safety enhancements.

The results of the operational analysis determined that the estimated increase in traffic during the peak periods resulting from the proposed residential development project will have a negligible impact on

overall traffic operations along Broad Rock Road and Saugatucket Road as presented in the summary tables.

Therefore, based upon the data collected on the servicing roadways, the analysis completed as part of this study, along with the access design, the proposed residential development project was determined to have adequate and safe access to a public street, and will not have an adverse impact on public safety and welfare in the study area.

# APPENDIX

- 
- A. Traffic Volume Data
  - B. Traffic Crash Data
  - C. Trip Generation
  - D. Operational Analysis

# APPENDIX A – Traffic Volume Data

---

Automatic Traffic Recorder Count

Broad Rock Road

Intersection Turning Movement Count

Broad Rock Road at Saugatucket Road

A

Automatic Traffic Recorder Count

Broad Rock Road

Broad Rock Road

*Traffic Volumes*

Project Name: Broad Rock Condos  
 Town / City, State: South Kingstown, RI  
 Roadway: Broad Rock Road  
 Location: at Woodmist Circle

**BETA Group, Inc.**  
 701 George Washington Highway  
 Lincoln, Rhode Island 02865  
 401.333.2382

Start Date: 4/17/2023  
 End Date: 4/25/2023

Time	4/17/23 Mon	4/18/23 Tue	4/19/23 Wed	4/20/23 Thu	4/21/23 Fri	Weekday Average	4/22/23 Sat	4/23/23 Sun
12:00 AM	*	3	4	0	5	3	7	7
01:00	*	3	0	1	1	1	5	1
02:00	*	0	2	1	1	1	1	0
03:00	*	1	3	1	2	2	3	2
04:00	*	3	3	4	6	4	2	2
05:00	*	13	18	14	12	14	11	5
06:00	*	36	36	41	40	38	15	17
07:00	*	96	114	94	123	107	35	16
08:00	*	149	114	123	117	126	83	42
09:00	*	88	84	87	79	84	83	66
10:00	*	83	92	71	94	85	100	67
11:00	*	83	77	83	92	84	92	60
12:00 PM	*	80	91	87	108	92	115	80
01:00	*	79	89	88	118	94	96	61
02:00	*	114	116	101	102	108	97	48
03:00	56	143	134	126	143	120	100	51
04:00	115	115	119	132	153	127	79	59
05:00	102	122	100	135	125	117	75	47
06:00	57	86	69	91	84	77	45	35
07:00	54	67	48	54	51	55	35	31
08:00	22	29	35	32	35	31	28	16
09:00	14	19	22	28	21	21	15	17
10:00	12	10	13	11	11	11	11	5
11:00	5	5	5	3	9	5	7	1
Total	437	1427	1388	1408	1532	1407	1140	736
Percent	31.1%	101.4%	98.6%	100.1%	108.9%		81.0%	52.3%
AM Peak		08:00	07:00	08:00	07:00	08:00	10:00	10:00
Volume		149	114	123	123	126	100	67
PM Peak	04:00	03:00	03:00	05:00	04:00	04:00	12:00 PM	12:00 PM
Volume	115	143	134	135	153	127	115	80

Project Name: Broad Rock Condos  
 Town / City, State: South Kingstown, RI  
 Roadway: Broad Rock Road  
 Location: at Woodmist Circle

**BETA Group, Inc.**  
 701 George Washington Highway  
 Lincoln, Rhode Island 02865  
 401.333.2382

Start Date: 4/17/2023  
 End Date: 4/25/2023

Time	4/24/23 Mon	4/25/23 Tue	4/26/23 Wed	4/27/23 Thu	4/28/23 Fri	Weekday Average	4/29/23 Sat	4/30/23 Sun
12:00 AM	1	2	*	*	*	2	*	*
01:00	1	0	*	*	*	0	*	*
02:00	0	0	*	*	*	0	*	*
03:00	2	3	*	*	*	2	*	*
04:00	5	2	*	*	*	4	*	*
05:00	16	15	*	*	*	16	*	*
06:00	34	43	*	*	*	38	*	*
07:00	76	90	*	*	*	83	*	*
08:00	111	77	*	*	*	94	*	*
09:00	74	20	*	*	*	47	*	*
10:00	86	*	*	*	*	86	*	*
11:00	79	*	*	*	*	79	*	*
12:00 PM	100	*	*	*	*	100	*	*
01:00	94	*	*	*	*	94	*	*
02:00	116	*	*	*	*	116	*	*
03:00	138	*	*	*	*	138	*	*
04:00	127	*	*	*	*	127	*	*
05:00	116	*	*	*	*	116	*	*
06:00	67	*	*	*	*	67	*	*
07:00	52	*	*	*	*	52	*	*
08:00	30	*	*	*	*	30	*	*
09:00	9	*	*	*	*	9	*	*
10:00	11	*	*	*	*	11	*	*
11:00	7	*	*	*	*	7	*	*
Total	1352	252	0	0	0	1318	0	0
Percent	102.6%	19.1%	0.0%	0.0%	0.0%		0.0%	0.0%
AM Peak	08:00	07:00				08:00		
Volume	111	90				94		
PM Peak	03:00					03:00		
Volume	138					138		

Project Name: Broad Rock Condos  
 Town / City, State: South Kingstown, RI  
 Roadway: Broad Rock Road  
 Location: at Woodmist Circle

**BETA Group, Inc.**  
 701 George Washington Highway  
 Lincoln, Rhode Island 02865  
 401.333.2382

Start Date: 4/17/2023  
 End Date: 4/25/2023

4/17/2023	Monday		Tuesday		Wednesday		Thursday		Friday		Weekday Average		Saturday		Sunday	
Time	South, Lane 1	North, Lane 2	South, Lane 1	North, Lane 2	South, Lane 1	North, Lane 2	South, Lane 1	North, Lane 2	South, Lane 1	North, Lane 2	South, Lane 1	North, Lane 2	South, Lane 1	North, Lane 2	South, Lane 1	North, Lane 2
12:00 AM	*	*	0	3	1	3	0	0	3	2	1	2	2	5	3	4
1:00	*	*	3	0	0	0	0	1	0	1	1	0	2	3	0	1
2:00	*	*	0	0	1	1	0	1	0	1	0	1	1	0	0	0
3:00	*	*	0	1	1	2	0	1	0	2	0	2	1	2	0	2
4:00	*	*	2	1	2	1	3	1	4	2	3	1	1	1	2	0
5:00	*	*	2	11	6	12	3	11	2	10	3	11	3	8	0	5
6:00	*	*	10	26	10	26	8	33	11	29	10	28	5	10	5	12
7:00	*	*	37	59	37	77	37	57	46	77	39	68	6	29	4	12
8:00	*	*	46	103	41	73	44	79	36	81	42	84	31	52	11	31
9:00	*	*	29	59	31	53	36	51	33	46	32	52	28	55	21	45
10:00	*	*	37	46	30	62	25	46	37	57	32	53	34	66	29	38
11:00	*	*	30	53	26	51	38	45	36	56	32	51	41	51	24	36
12:00 PM	*	*	25	55	32	59	30	57	46	62	33	58	44	71	21	59
1:00	*	*	34	45	29	60	25	63	34	84	30	63	38	58	19	42
2:00	*	*	35	79	33	83	34	67	35	67	34	74	29	68	11	37
3:00	14	42	39	104	42	92	34	92	35	108	33	88	37	63	7	44
4:00	39	76	44	71	46	73	41	91	57	96	45	81	29	50	24	35
5:00	32	70	50	72	28	72	40	95	39	86	38	79	26	49	14	33
6:00	24	33	23	63	29	40	31	60	23	61	26	51	16	29	11	24
7:00	27	27	37	30	25	23	20	34	25	26	27	28	10	25	16	15
8:00	14	8	18	11	19	16	14	18	21	14	17	13	13	15	7	9
9:00	8	6	11	8	16	6	13	15	6	15	11	10	5	10	3	14
10:00	2	10	5	5	3	10	7	4	6	5	5	7	2	9	3	2
11:00	2	3	4	1	2	3	2	1	1	8	2	3	3	4	0	1
Total	162	275	521	906	490	898	485	923	536	996	496	908	407	733	235	501
Day	437		1427		1388		1408		1532		1404		1140		736	
AM Peak			8:00	8:00	8:00	7:00	8:00	8:00	7:00	8:00	8:00	8:00	11:00	10:00	10:00	9:00
Volume			46	103	41	77	44	79	46	81	42	84	41	66	29	45
PM Peak	4:00	4:00	5:00	3:00	4:00	3:00	4:00	5:00	4:00	3:00	4:00	3:00	12:00 PM	12:00 PM	4:00	12:00 PM
Volume	39	76	50	104	46	92	41	95	57	108	45	88	44	71	24	59

Project Name: Broad Rock Condos  
 Town / City, State: South Kingstown, RI  
 Roadway: Broad Rock Road  
 Location: at Woodmist Circle

**BETA Group, Inc.**  
 701 George Washington Highway  
 Lincoln, Rhode Island 02865  
 401.333.2382

Start Date: 4/17/2023  
 End Date: 4/25/2023

4/24/2023	Monday		Tuesday		Wednesday		Thursday		Friday		Weekday Average		Saturday		Sunday	
Time	South, Lane 1	North, Lane 2	South, Lane 1	North, Lane 2	South, Lane 1	North, Lane 2	South, Lane 1	North, Lane 2	South, Lane 1	North, Lane 2	South, Lane 1	North, Lane 2	South, Lane 1	North, Lane 2	South, Lane 1	North, Lane 2
12:00 AM	1	0	0	2	*	*	*	*	*	*	0	1	*	*	*	*
1:00	0	1	0	0	*	*	*	*	*	*	0	0	*	*	*	*
2:00	0	0	0	0	*	*	*	*	*	*	0	0	*	*	*	*
3:00	1	1	0	3	*	*	*	*	*	*	0	2	*	*	*	*
4:00	2	3	0	2	*	*	*	*	*	*	1	2	*	*	*	*
5:00	2	14	2	13	*	*	*	*	*	*	2	14	*	*	*	*
6:00	12	22	14	29	*	*	*	*	*	*	13	26	*	*	*	*
7:00	21	55	41	49	*	*	*	*	*	*	31	52	*	*	*	*
8:00	25	86	27	50	*	*	*	*	*	*	26	68	*	*	*	*
9:00	25	49	0	20	*	*	*	*	*	*	12	34	*	*	*	*
10:00	33	53	*	*	*	*	*	*	*	*	33	53	*	*	*	*
11:00	30	49	*	*	*	*	*	*	*	*	30	49	*	*	*	*
12:00 PM	39	61	*	*	*	*	*	*	*	*	39	61	*	*	*	*
1:00	38	56	*	*	*	*	*	*	*	*	38	56	*	*	*	*
2:00	46	70	*	*	*	*	*	*	*	*	46	70	*	*	*	*
3:00	44	94	*	*	*	*	*	*	*	*	44	94	*	*	*	*
4:00	33	94	*	*	*	*	*	*	*	*	33	94	*	*	*	*
5:00	35	81	*	*	*	*	*	*	*	*	35	81	*	*	*	*
6:00	27	40	*	*	*	*	*	*	*	*	27	40	*	*	*	*
7:00	30	22	*	*	*	*	*	*	*	*	30	22	*	*	*	*
8:00	20	10	*	*	*	*	*	*	*	*	20	10	*	*	*	*
9:00	4	5	*	*	*	*	*	*	*	*	4	5	*	*	*	*
10:00	5	6	*	*	*	*	*	*	*	*	5	6	*	*	*	*
11:00	2	5	*	*	*	*	*	*	*	*	2	5	*	*	*	*
Total	475	877	84	168	0	0	0	0	0	0	471	845	0	0	0	0
Day	1352		252		0		0		0		1316		0		0	
AM Peak	10:00	8:00	7:00	8:00							10:00	8:00				
Volume	33	86	41	50							33	68				
PM Peak	2:00	3:00									2:00	3:00				
Volume	46	94									46	94				
Comb Total	1789		1679		1388		1408		1532		2720		1140		736	
ADT	ADT: 1,265		AADT: 1,265													

*Speeds*

Project Name: Broad Rock Condos  
 Town / City, State: South Kingstown, RI  
 Roadway: Broad Rock Road  
 Location: at Woodmist Circle

**BETA Group, Inc.**  
 701 George Washington Highway  
 Lincoln, Rhode Island 02865  
 401.333.2382

Start Date: 4/17/2023  
 End Date: 4/25/2023

Direction: South, Lane 1

4/17/2023 Time	0 - 15 MPH	> 15 - 20 MPH	> 20 - 25 MPH	> 25 - 30 MPH	> 30 - 35 MPH	> 35 - 40 MPH	> 40 - 45 MPH	> 45 - 50 MPH	> 50 - 55 MPH	> 55 - 60 MPH	> 60 - 65 MPH	> 65 - 70 MPH	> 70 MPH	Total
12:00 AM	*	*	*	*	*	*	*	*	*	*	*	*	*	0
1:00	*	*	*	*	*	*	*	*	*	*	*	*	*	0
2:00	*	*	*	*	*	*	*	*	*	*	*	*	*	0
3:00	*	*	*	*	*	*	*	*	*	*	*	*	*	0
4:00	*	*	*	*	*	*	*	*	*	*	*	*	*	0
5:00	*	*	*	*	*	*	*	*	*	*	*	*	*	0
6:00	*	*	*	*	*	*	*	*	*	*	*	*	*	0
7:00	*	*	*	*	*	*	*	*	*	*	*	*	*	0
8:00	*	*	*	*	*	*	*	*	*	*	*	*	*	0
9:00	*	*	*	*	*	*	*	*	*	*	*	*	*	0
10:00	*	*	*	*	*	*	*	*	*	*	*	*	*	0
11:00	*	*	*	*	*	*	*	*	*	*	*	*	*	0
12:00 PM	*	*	*	*	*	*	*	*	*	*	*	*	*	0
1:00	*	*	*	*	*	*	*	*	*	*	*	*	*	0
2:00	*	*	*	*	*	*	*	*	*	*	*	*	*	0
3:00	1	0	8	4	0	0	0	0	0	1	0	0	0	14
4:00	0	3	14	14	7	1	0	0	0	0	0	0	0	39
5:00	0	4	15	7	5	1	0	0	0	0	0	0	0	32
6:00	1	3	8	9	3	0	0	0	0	0	0	0	0	24
7:00	1	5	9	7	4	1	0	0	0	0	0	0	0	27
8:00	0	0	11	2	1	0	0	0	0	0	0	0	0	14
9:00	1	2	1	3	1	0	0	0	0	0	0	0	0	8
10:00	0	1	0	1	0	0	0	0	0	0	0	0	0	2
11:00	1	1	0	0	0	0	0	0	0	0	0	0	0	2
Total	5	19	66	47	21	3	0	0	0	1	0	0	0	162

Project Name: Broad Rock Condos  
 Town / City, State: South Kingstown, RI  
 Roadway: Broad Rock Road  
 Location: at Woodmist Circle

**BETA Group, Inc.**  
 701 George Washington Highway  
 Lincoln, Rhode Island 02865  
 401.333.2382

Start Date: 4/17/2023  
 End Date: 4/25/2023

Direction: South, Lane 1

4/18/2023	0 - 15	> 15 -	> 20 -	> 25 -	> 30 -	> 35 -	> 40 -	> 45 -	> 50 -	> 55 -	> 60 -	> 65 -	> 70	Total
Time	MPH	20 MPH	25 MPH	30 MPH	35 MPH	40 MPH	45 MPH	50 MPH	55 MPH	60 MPH	65 MPH	70 MPH	MPH	
12:00 AM	0	0	0	0	0	0	0	0	0	0	0	0	0	0
1:00	0	0	2	1	0	0	0	0	0	0	0	0	0	3
2:00	0	0	0	0	0	0	0	0	0	0	0	0	0	0
3:00	0	0	0	0	0	0	0	0	0	0	0	0	0	0
4:00	0	0	2	0	0	0	0	0	0	0	0	0	0	2
5:00	0	0	1	1	0	0	0	0	0	0	0	0	0	2
6:00	0	0	1	5	2	1	1	0	0	0	0	0	0	10
7:00	0	1	13	12	8	2	1	0	0	0	0	0	0	37
8:00	2	4	14	11	13	2	0	0	0	0	0	0	0	46
9:00	0	3	13	6	6	0	1	0	0	0	0	0	0	29
10:00	0	3	14	15	5	0	0	0	0	0	0	0	0	37
11:00	1	1	9	14	4	1	0	0	0	0	0	0	0	30
12:00 PM	1	0	13	5	5	1	0	0	0	0	0	0	0	25
1:00	2	6	14	11	1	0	0	0	0	0	0	0	0	34
2:00	0	7	13	13	2	0	0	0	0	0	0	0	0	35
3:00	0	6	18	12	2	1	0	0	0	0	0	0	0	39
4:00	0	6	15	21	2	0	0	0	0	0	0	0	0	44
5:00	0	5	17	17	8	2	0	0	1	0	0	0	0	50
6:00	1	3	7	8	3	1	0	0	0	0	0	0	0	23
7:00	1	6	14	11	4	0	0	0	1	0	0	0	0	37
8:00	0	3	6	8	1	0	0	0	0	0	0	0	0	18
9:00	0	1	4	3	2	1	0	0	0	0	0	0	0	11
10:00	0	0	2	1	2	0	0	0	0	0	0	0	0	5
11:00	0	2	1	1	0	0	0	0	0	0	0	0	0	4
<b>Total</b>	<b>8</b>	<b>57</b>	<b>193</b>	<b>176</b>	<b>70</b>	<b>12</b>	<b>3</b>	<b>0</b>	<b>2</b>	<b>0</b>	<b>0</b>	<b>0</b>	<b>0</b>	<b>521</b>

Project Name: Broad Rock Condos  
 Town / City, State: South Kingstown, RI  
 Roadway: Broad Rock Road  
 Location: at Woodmist Circle

**BETA Group, Inc.**  
 701 George Washington Highway  
 Lincoln, Rhode Island 02865  
 401.333.2382

Start Date: 4/17/2023  
 End Date: 4/25/2023

Direction: South, Lane 1

4/19/2023	0 - 15	> 15 -	> 20 -	> 25 -	> 30 -	> 35 -	> 40 -	> 45 -	> 50 -	> 55 -	> 60 -	> 65 -	> 70	Total
Time	MPH	20 MPH	25 MPH	30 MPH	35 MPH	40 MPH	45 MPH	50 MPH	55 MPH	60 MPH	65 MPH	70 MPH	MPH	
12:00 AM	0	0	1	0	0	0	0	0	0	0	0	0	0	1
1:00	0	0	0	0	0	0	0	0	0	0	0	0	0	0
2:00	0	1	0	0	0	0	0	0	0	0	0	0	0	1
3:00	0	0	0	0	0	1	0	0	0	0	0	0	0	1
4:00	0	0	0	2	0	0	0	0	0	0	0	0	0	2
5:00	0	2	1	1	1	0	1	0	0	0	0	0	0	6
6:00	0	1	3	3	3	0	0	0	0	0	0	0	0	10
7:00	0	0	11	16	8	2	0	0	0	0	0	0	0	37
8:00	0	0	17	12	9	1	2	0	0	0	0	0	0	41
9:00	1	3	13	9	3	1	1	0	0	0	0	0	0	31
10:00	0	3	16	8	3	0	0	0	0	0	0	0	0	30
11:00	0	7	9	7	2	0	1	0	0	0	0	0	0	26
12:00 PM	2	9	10	7	2	1	1	0	0	0	0	0	0	32
1:00	2	5	13	6	2	1	0	0	0	0	0	0	0	29
2:00	0	6	11	12	4	0	0	0	0	0	0	0	0	33
3:00	1	6	20	10	5	0	0	0	0	0	0	0	0	42
4:00	0	2	15	20	5	3	1	0	0	0	0	0	0	46
5:00	1	3	13	9	1	1	0	0	0	0	0	0	0	28
6:00	0	7	10	9	3	0	0	0	0	0	0	0	0	29
7:00	0	5	10	5	5	0	0	0	0	0	0	0	0	25
8:00	1	0	11	6	1	0	0	0	0	0	0	0	0	19
9:00	0	2	9	3	2	0	0	0	0	0	0	0	0	16
10:00	0	0	0	2	1	0	0	0	0	0	0	0	0	3
11:00	0	1	0	1	0	0	0	0	0	0	0	0	0	2
<b>Total</b>	<b>8</b>	<b>63</b>	<b>193</b>	<b>148</b>	<b>60</b>	<b>11</b>	<b>7</b>	<b>0</b>	<b>0</b>	<b>0</b>	<b>0</b>	<b>0</b>	<b>0</b>	<b>490</b>

Project Name: Broad Rock Condos  
 Town / City, State: South Kingstown, RI  
 Roadway: Broad Rock Road  
 Location: at Woodmist Circle

**BETA Group, Inc.**  
 701 George Washington Highway  
 Lincoln, Rhode Island 02865  
 401.333.2382

Start Date: 4/17/2023  
 End Date: 4/25/2023

Direction: South, Lane 1

4/20/2023	0 - 15	> 15 -	> 20 -	> 25 -	> 30 -	> 35 -	> 40 -	> 45 -	> 50 -	> 55 -	> 60 -	> 65 -	> 70	Total
Time	MPH	20 MPH	25 MPH	30 MPH	35 MPH	40 MPH	45 MPH	50 MPH	55 MPH	60 MPH	65 MPH	70 MPH	MPH	
12:00 AM	0	0	0	0	0	0	0	0	0	0	0	0	0	0
1:00	0	0	0	0	0	0	0	0	0	0	0	0	0	0
2:00	0	0	0	0	0	0	0	0	0	0	0	0	0	0
3:00	0	0	0	0	0	0	0	0	0	0	0	0	0	0
4:00	0	0	2	1	0	0	0	0	0	0	0	0	0	3
5:00	0	1	2	0	0	0	0	0	0	0	0	0	0	3
6:00	0	0	4	1	1	1	0	1	0	0	0	0	0	8
7:00	0	2	13	15	4	2	1	0	0	0	0	0	0	37
8:00	1	3	11	24	3	1	0	0	0	0	1	0	0	44
9:00	1	7	12	12	3	1	0	0	0	0	0	0	0	36
10:00	3	6	5	4	5	2	0	0	0	0	0	0	0	25
11:00	3	3	16	13	1	1	0	1	0	0	0	0	0	38
12:00 PM	3	0	10	13	1	3	0	0	0	0	0	0	0	30
1:00	0	3	10	12	0	0	0	0	0	0	0	0	0	25
2:00	1	3	15	6	8	1	0	0	0	0	0	0	0	34
3:00	1	1	16	10	3	3	0	0	0	0	0	0	0	34
4:00	1	5	17	14	4	0	0	0	0	0	0	0	0	41
5:00	1	3	14	12	7	2	0	1	0	0	0	0	0	40
6:00	1	0	14	12	2	2	0	0	0	0	0	0	0	31
7:00	0	3	9	5	2	0	0	1	0	0	0	0	0	20
8:00	0	3	5	5	1	0	0	0	0	0	0	0	0	14
9:00	0	4	4	4	1	0	0	0	0	0	0	0	0	13
10:00	0	1	1	4	1	0	0	0	0	0	0	0	0	7
11:00	0	0	1	1	0	0	0	0	0	0	0	0	0	2
<b>Total</b>	<b>16</b>	<b>48</b>	<b>181</b>	<b>168</b>	<b>47</b>	<b>19</b>	<b>1</b>	<b>4</b>	<b>0</b>	<b>0</b>	<b>1</b>	<b>0</b>	<b>0</b>	<b>485</b>

Project Name: Broad Rock Condos  
 Town / City, State: South Kingstown, RI  
 Roadway: Broad Rock Road  
 Location: at Woodmist Circle

**BETA Group, Inc.**  
 701 George Washington Highway  
 Lincoln, Rhode Island 02865  
 401.333.2382

Start Date: 4/17/2023  
 End Date: 4/25/2023

Direction: South, Lane 1

4/21/2023 Time	0 - 15 MPH	> 15 - 20 MPH	> 20 - 25 MPH	> 25 - 30 MPH	> 30 - 35 MPH	> 35 - 40 MPH	> 40 - 45 MPH	> 45 - 50 MPH	> 50 - 55 MPH	> 55 - 60 MPH	> 60 - 65 MPH	> 65 - 70 MPH	> 70 MPH	Total
12:00 AM	0	0	1	1	1	0	0	0	0	0	0	0	0	3
1:00	0	0	0	0	0	0	0	0	0	0	0	0	0	0
2:00	0	0	0	0	0	0	0	0	0	0	0	0	0	0
3:00	0	0	0	0	0	0	0	0	0	0	0	0	0	0
4:00	0	1	2	1	0	0	0	0	0	0	0	0	0	4
5:00	0	0	1	0	0	0	0	1	0	0	0	0	0	2
6:00	0	1	1	2	5	1	1	0	0	0	0	0	0	11
7:00	1	2	10	22	10	1	0	0	0	0	0	0	0	46
8:00	1	1	16	15	2	1	0	0	0	0	0	0	0	36
9:00	0	0	13	13	7	0	0	0	0	0	0	0	0	33
10:00	0	5	15	10	6	1	0	0	0	0	0	0	0	37
11:00	1	3	14	14	3	1	0	0	0	0	0	0	0	36
12:00 PM	2	4	19	15	5	0	1	0	0	0	0	0	0	46
1:00	1	4	13	9	5	2	0	0	0	0	0	0	0	34
2:00	0	7	14	10	4	0	0	0	0	0	0	0	0	35
3:00	1	4	12	12	5	1	0	0	0	0	0	0	0	35
4:00	3	12	19	23	0	0	0	0	0	0	0	0	0	57
5:00	1	3	12	16	6	1	0	0	0	0	0	0	0	39
6:00	1	4	7	6	4	1	0	0	0	0	0	0	0	23
7:00	1	3	10	10	1	0	0	0	0	0	0	0	0	25
8:00	0	1	11	8	1	0	0	0	0	0	0	0	0	21
9:00	0	0	2	4	0	0	0	0	0	0	0	0	0	6
10:00	0	1	4	1	0	0	0	0	0	0	0	0	0	6
11:00	0	0	1	0	0	0	0	0	0	0	0	0	0	1
<b>Total</b>	<b>13</b>	<b>56</b>	<b>197</b>	<b>192</b>	<b>65</b>	<b>10</b>	<b>2</b>	<b>1</b>	<b>0</b>	<b>0</b>	<b>0</b>	<b>0</b>	<b>0</b>	<b>536</b>

Project Name: Broad Rock Condos  
 Town / City, State: South Kingstown, RI  
 Roadway: Broad Rock Road  
 Location: at Woodmist Circle

**BETA Group, Inc.**  
 701 George Washington Highway  
 Lincoln, Rhode Island 02865  
 401.333.2382

Start Date: 4/17/2023  
 End Date: 4/25/2023

Direction: South, Lane 1

4/22/2023	0 - 15	> 15 -	> 20 -	> 25 -	> 30 -	> 35 -	> 40 -	> 45 -	> 50 -	> 55 -	> 60 -	> 65 -	> 70	Total
Time	MPH	20 MPH	25 MPH	30 MPH	35 MPH	40 MPH	45 MPH	50 MPH	55 MPH	60 MPH	65 MPH	70 MPH	MPH	
12:00 AM	0	0	1	1	0	0	0	0	0	0	0	0	0	2
1:00	0	0	0	2	0	0	0	0	0	0	0	0	0	2
2:00	0	0	0	1	0	0	0	0	0	0	0	0	0	1
3:00	0	0	0	1	0	0	0	0	0	0	0	0	0	1
4:00	0	0	1	0	0	0	0	0	0	0	0	0	0	1
5:00	0	0	1	1	1	0	0	0	0	0	0	0	0	3
6:00	0	0	2	1	2	0	0	0	0	0	0	0	0	5
7:00	1	0	3	0	2	0	0	0	0	0	0	0	0	6
8:00	1	4	13	10	3	0	0	0	0	0	0	0	0	31
9:00	0	1	15	8	4	0	0	0	0	0	0	0	0	28
10:00	2	5	13	10	3	1	0	0	0	0	0	0	0	34
11:00	0	2	16	15	6	1	0	0	1	0	0	0	0	41
12:00 PM	2	4	17	13	5	3	0	0	0	0	0	0	0	44
1:00	0	5	15	14	4	0	0	0	0	0	0	0	0	38
2:00	0	2	8	14	4	1	0	0	0	0	0	0	0	29
3:00	1	1	10	15	6	4	0	0	0	0	0	0	0	37
4:00	0	2	11	14	2	0	0	0	0	0	0	0	0	29
5:00	0	1	10	11	4	0	0	0	0	0	0	0	0	26
6:00	0	2	6	7	1	0	0	0	0	0	0	0	0	16
7:00	0	1	4	3	1	1	0	0	0	0	0	0	0	10
8:00	0	2	4	5	2	0	0	0	0	0	0	0	0	13
9:00	0	0	2	3	0	0	0	0	0	0	0	0	0	5
10:00	0	1	0	0	1	0	0	0	0	0	0	0	0	2
11:00	0	0	2	1	0	0	0	0	0	0	0	0	0	3
<b>Total</b>	<b>7</b>	<b>33</b>	<b>154</b>	<b>150</b>	<b>51</b>	<b>11</b>	<b>0</b>	<b>0</b>	<b>1</b>	<b>0</b>	<b>0</b>	<b>0</b>	<b>0</b>	<b>407</b>

Project Name: Broad Rock Condos  
 Town / City, State: South Kingstown, RI  
 Roadway: Broad Rock Road  
 Location: at Woodmist Circle

**BETA Group, Inc.**  
 701 George Washington Highway  
 Lincoln, Rhode Island 02865  
 401.333.2382

Start Date: 4/17/2023  
 End Date: 4/25/2023

Direction: South, Lane 1

4/23/2023	0 - 15	> 15 -	> 20 -	> 25 -	> 30 -	> 35 -	> 40 -	> 45 -	> 50 -	> 55 -	> 60 -	> 65 -	> 70	Total
Time	MPH	20 MPH	25 MPH	30 MPH	35 MPH	40 MPH	45 MPH	50 MPH	55 MPH	60 MPH	65 MPH	70 MPH	MPH	
12:00 AM	0	0	1	1	1	0	0	0	0	0	0	0	0	3
1:00	0	0	0	0	0	0	0	0	0	0	0	0	0	0
2:00	0	0	0	0	0	0	0	0	0	0	0	0	0	0
3:00	0	0	0	0	0	0	0	0	0	0	0	0	0	0
4:00	0	0	0	1	1	0	0	0	0	0	0	0	0	2
5:00	0	0	0	0	0	0	0	0	0	0	0	0	0	0
6:00	0	0	2	1	1	0	1	0	0	0	0	0	0	5
7:00	0	1	2	1	0	0	0	0	0	0	0	0	0	4
8:00	0	0	6	5	0	0	0	0	0	0	0	0	0	11
9:00	0	1	9	6	4	1	0	0	0	0	0	0	0	21
10:00	1	3	10	12	3	0	0	0	0	0	0	0	0	29
11:00	0	0	6	13	5	0	0	0	0	0	0	0	0	24
12:00 PM	0	3	10	6	2	0	0	0	0	0	0	0	0	21
1:00	0	2	4	10	3	0	0	0	0	0	0	0	0	19
2:00	0	1	5	5	0	0	0	0	0	0	0	0	0	11
3:00	0	1	1	4	1	0	0	0	0	0	0	0	0	7
4:00	0	4	10	7	2	1	0	0	0	0	0	0	0	24
5:00	0	2	7	4	1	0	0	0	0	0	0	0	0	14
6:00	0	0	6	5	0	0	0	0	0	0	0	0	0	11
7:00	1	0	10	4	1	0	0	0	0	0	0	0	0	16
8:00	0	1	3	3	0	0	0	0	0	0	0	0	0	7
9:00	0	0	3	0	0	0	0	0	0	0	0	0	0	3
10:00	1	0	1	1	0	0	0	0	0	0	0	0	0	3
11:00	0	0	0	0	0	0	0	0	0	0	0	0	0	0
Total	3	19	96	89	25	2	1	0	0	0	0	0	0	235

Project Name: Broad Rock Condos  
 Town / City, State: South Kingstown, RI  
 Roadway: Broad Rock Road  
 Location: at Woodmist Circle

**BETA Group, Inc.**  
 701 George Washington Highway  
 Lincoln, Rhode Island 02865  
 401.333.2382

Start Date: 4/17/2023  
 End Date: 4/25/2023

Direction: South, Lane 1

4/24/2023	0 - 15	> 15 -	> 20 -	> 25 -	> 30 -	> 35 -	> 40 -	> 45 -	> 50 -	> 55 -	> 60 -	> 65 -	> 70	Total
Time	MPH	20 MPH	25 MPH	30 MPH	35 MPH	40 MPH	45 MPH	50 MPH	55 MPH	60 MPH	65 MPH	70 MPH	MPH	
12:00 AM	0	0	1	0	0	0	0	0	0	0	0	0	0	1
1:00	0	0	0	0	0	0	0	0	0	0	0	0	0	0
2:00	0	0	0	0	0	0	0	0	0	0	0	0	0	0
3:00	0	0	1	0	0	0	0	0	0	0	0	0	0	1
4:00	0	0	1	1	0	0	0	0	0	0	0	0	0	2
5:00	0	0	2	0	0	0	0	0	0	0	0	0	0	2
6:00	0	1	5	2	4	0	0	0	0	0	0	0	0	12
7:00	0	1	5	12	0	3	0	0	0	0	0	0	0	21
8:00	0	0	13	7	4	1	0	0	0	0	0	0	0	25
9:00	0	3	10	9	3	0	0	0	0	0	0	0	0	25
10:00	2	5	15	8	2	0	1	0	0	0	0	0	0	33
11:00	2	3	8	13	3	1	0	0	0	0	0	0	0	30
12:00 PM	2	6	15	11	4	1	0	0	0	0	0	0	0	39
1:00	2	8	11	11	6	0	0	0	0	0	0	0	0	38
2:00	1	10	15	16	4	0	0	0	0	0	0	0	0	46
3:00	2	7	17	14	3	1	0	0	0	0	0	0	0	44
4:00	1	5	15	10	2	0	0	0	0	0	0	0	0	33
5:00	1	3	13	14	4	0	0	0	0	0	0	0	0	35
6:00	2	5	10	7	3	0	0	0	0	0	0	0	0	27
7:00	0	4	13	10	3	0	0	0	0	0	0	0	0	30
8:00	1	1	11	4	2	1	0	0	0	0	0	0	0	20
9:00	0	0	3	1	0	0	0	0	0	0	0	0	0	4
10:00	0	1	2	2	0	0	0	0	0	0	0	0	0	5
11:00	0	0	1	0	1	0	0	0	0	0	0	0	0	2
<b>Total</b>	<b>16</b>	<b>63</b>	<b>187</b>	<b>152</b>	<b>48</b>	<b>8</b>	<b>1</b>	<b>0</b>	<b>0</b>	<b>0</b>	<b>0</b>	<b>0</b>	<b>0</b>	<b>475</b>

Project Name: Broad Rock Condos  
 Town / City, State: South Kingstown, RI  
 Roadway: Broad Rock Road  
 Location: at Woodmist Circle

**BETA Group, Inc.**  
 701 George Washington Highway  
 Lincoln, Rhode Island 02865  
 401.333.2382

Start Date: 4/17/2023  
 End Date: 4/25/2023

Direction: South, Lane 1

4/25/2023 Time	0 - 15 MPH	> 15 - 20 MPH	> 20 - 25 MPH	> 25 - 30 MPH	> 30 - 35 MPH	> 35 - 40 MPH	> 40 - 45 MPH	> 45 - 50 MPH	> 50 - 55 MPH	> 55 - 60 MPH	> 60 - 65 MPH	> 65 - 70 MPH	> 70 MPH	Total
12:00 AM	0	0	0	0	0	0	0	0	0	0	0	0	0	0
1:00	0	0	0	0	0	0	0	0	0	0	0	0	0	0
2:00	0	0	0	0	0	0	0	0	0	0	0	0	0	0
3:00	0	0	0	0	0	0	0	0	0	0	0	0	0	0
4:00	0	0	0	0	0	0	0	0	0	0	0	0	0	0
5:00	0	0	0	1	0	0	1	0	0	0	0	0	0	2
6:00	0	2	3	6	2	1	0	0	0	0	0	0	0	14
7:00	0	3	7	17	13	1	0	0	0	0	0	0	0	41
8:00	0	1	8	10	6	2	0	0	0	0	0	0	0	27
9:00	0	0	0	0	0	0	0	0	0	0	0	0	0	0
10:00	*	*	*	*	*	*	*	*	*	*	*	*	*	0
11:00	*	*	*	*	*	*	*	*	*	*	*	*	*	0
12:00 PM	*	*	*	*	*	*	*	*	*	*	*	*	*	0
1:00	*	*	*	*	*	*	*	*	*	*	*	*	*	0
2:00	*	*	*	*	*	*	*	*	*	*	*	*	*	0
3:00	*	*	*	*	*	*	*	*	*	*	*	*	*	0
4:00	*	*	*	*	*	*	*	*	*	*	*	*	*	0
5:00	*	*	*	*	*	*	*	*	*	*	*	*	*	0
6:00	*	*	*	*	*	*	*	*	*	*	*	*	*	0
7:00	*	*	*	*	*	*	*	*	*	*	*	*	*	0
8:00	*	*	*	*	*	*	*	*	*	*	*	*	*	0
9:00	*	*	*	*	*	*	*	*	*	*	*	*	*	0
10:00	*	*	*	*	*	*	*	*	*	*	*	*	*	0
11:00	*	*	*	*	*	*	*	*	*	*	*	*	*	0
<b>Total</b>	<b>0</b>	<b>6</b>	<b>18</b>	<b>34</b>	<b>21</b>	<b>4</b>	<b>1</b>	<b>0</b>	<b>0</b>	<b>0</b>	<b>0</b>	<b>0</b>	<b>0</b>	<b>84</b>
<b>Grand Total</b>	<b>76</b>	<b>364</b>	<b>1285</b>	<b>1156</b>	<b>408</b>	<b>80</b>	<b>16</b>	<b>5</b>	<b>3</b>	<b>1</b>	<b>1</b>	<b>0</b>	<b>0</b>	<b>3395</b>
Stats			Percentile	15th	50th	85th	95th							
			Speed	20	25	30	34							
			Mean Speed (Average)	25.1										
			10 MPH Pace Speed	20-29										
			Number in Pace	2425										
			Percent in Pace	71.4%										
			Number > 25 MPH	1670										
			Percent > 25 MPH	49.2%										

Project Name: Broad Rock Condos  
 Town / City, State: South Kingstown, RI  
 Roadway: Broad Rock Road  
 Location: at Woodmist Circle

**BETA Group, Inc.**  
 701 George Washington Highway  
 Lincoln, Rhode Island 02865  
 401.333.2382

Start Date: 4/17/2023  
 End Date: 4/25/2023

Direction: North, Lane 2

4/17/2023	0 - 15	> 15 -	> 20 -	> 25 -	> 30 -	> 35 -	> 40 -	> 45 -	> 50 -	> 55 -	> 60 -	> 65 -	> 70	Total
Time	MPH	20 MPH	25 MPH	30 MPH	35 MPH	40 MPH	45 MPH	50 MPH	55 MPH	60 MPH	65 MPH	70 MPH	MPH	
12:00 AM	*	*	*	*	*	*	*	*	*	*	*	*	*	0
1:00	*	*	*	*	*	*	*	*	*	*	*	*	*	0
2:00	*	*	*	*	*	*	*	*	*	*	*	*	*	0
3:00	*	*	*	*	*	*	*	*	*	*	*	*	*	0
4:00	*	*	*	*	*	*	*	*	*	*	*	*	*	0
5:00	*	*	*	*	*	*	*	*	*	*	*	*	*	0
6:00	*	*	*	*	*	*	*	*	*	*	*	*	*	0
7:00	*	*	*	*	*	*	*	*	*	*	*	*	*	0
8:00	*	*	*	*	*	*	*	*	*	*	*	*	*	0
9:00	*	*	*	*	*	*	*	*	*	*	*	*	*	0
10:00	*	*	*	*	*	*	*	*	*	*	*	*	*	0
11:00	*	*	*	*	*	*	*	*	*	*	*	*	*	0
12:00 PM	*	*	*	*	*	*	*	*	*	*	*	*	*	0
1:00	*	*	*	*	*	*	*	*	*	*	*	*	*	0
2:00	*	*	*	*	*	*	*	*	*	*	*	*	*	0
3:00	0	0	2	13	17	7	3	0	0	0	0	0	0	42
4:00	0	0	7	19	28	15	7	0	0	0	0	0	0	76
5:00	0	0	5	22	21	17	4	1	0	0	0	0	0	70
6:00	0	0	5	10	14	3	1	0	0	0	0	0	0	33
7:00	1	0	2	7	13	4	0	0	0	0	0	0	0	27
8:00	0	0	2	3	1	2	0	0	0	0	0	0	0	8
9:00	0	0	2	0	4	0	0	0	0	0	0	0	0	6
10:00	0	0	3	3	3	1	0	0	0	0	0	0	0	10
11:00	0	0	0	1	2	0	0	0	0	0	0	0	0	3
Total	1	0	28	78	103	49	15	1	0	0	0	0	0	275

Project Name: Broad Rock Condos  
 Town / City, State: South Kingstown, RI  
 Roadway: Broad Rock Road  
 Location: at Woodmist Circle

**BETA Group, Inc.**  
 701 George Washington Highway  
 Lincoln, Rhode Island 02865  
 401.333.2382

Start Date: 4/17/2023  
 End Date: 4/25/2023

Direction: North, Lane 2

4/18/2023	0 - 15	> 15 -	> 20 -	> 25 -	> 30 -	> 35 -	> 40 -	> 45 -	> 50 -	> 55 -	> 60 -	> 65 -	> 70	Total
Time	MPH	20 MPH	25 MPH	30 MPH	35 MPH	40 MPH	45 MPH	50 MPH	55 MPH	60 MPH	65 MPH	70 MPH	MPH	
12:00 AM	0	0	0	0	1	1	1	0	0	0	0	0	0	3
1:00	0	0	0	0	0	0	0	0	0	0	0	0	0	0
2:00	0	0	0	0	0	0	0	0	0	0	0	0	0	0
3:00	0	0	0	1	0	0	0	0	0	0	0	0	0	1
4:00	0	0	0	0	0	0	0	1	0	0	0	0	0	1
5:00	0	1	2	7	1	0	0	0	0	0	0	0	0	11
6:00	0	1	5	10	6	4	0	0	0	0	0	0	0	26
7:00	0	1	6	17	21	13	1	0	0	0	0	0	0	59
8:00	3	6	16	43	23	11	1	0	0	0	0	0	0	103
9:00	2	1	6	24	16	8	2	0	0	0	0	0	0	59
10:00	1	0	5	14	19	5	2	0	0	0	0	0	0	46
11:00	1	1	6	16	17	7	4	1	0	0	0	0	0	53
12:00 PM	1	2	12	15	18	6	1	0	0	0	0	0	0	55
1:00	0	1	12	19	9	3	1	0	0	0	0	0	0	45
2:00	2	0	7	36	24	8	1	1	0	0	0	0	0	79
3:00	1	1	9	26	33	26	8	0	0	0	0	0	0	104
4:00	0	1	4	22	30	11	1	2	0	0	0	0	0	71
5:00	1	0	12	22	28	8	1	0	0	0	0	0	0	72
6:00	0	0	10	13	24	11	5	0	0	0	0	0	0	63
7:00	1	1	3	16	7	2	0	0	0	0	0	0	0	30
8:00	0	0	2	8	0	1	0	0	0	0	0	0	0	11
9:00	0	0	0	3	3	1	1	0	0	0	0	0	0	8
10:00	0	3	1	0	1	0	0	0	0	0	0	0	0	5
11:00	0	0	0	0	1	0	0	0	0	0	0	0	0	1
<b>Total</b>	<b>13</b>	<b>20</b>	<b>118</b>	<b>312</b>	<b>282</b>	<b>126</b>	<b>30</b>	<b>5</b>	<b>0</b>	<b>0</b>	<b>0</b>	<b>0</b>	<b>0</b>	<b>906</b>

Project Name: Broad Rock Condos  
 Town / City, State: South Kingstown, RI  
 Roadway: Broad Rock Road  
 Location: at Woodmist Circle

**BETA Group, Inc.**  
 701 George Washington Highway  
 Lincoln, Rhode Island 02865  
 401.333.2382

Start Date: 4/17/2023  
 End Date: 4/25/2023

Direction: North, Lane 2

4/19/2023	0 - 15	> 15 -	> 20 -	> 25 -	> 30 -	> 35 -	> 40 -	> 45 -	> 50 -	> 55 -	> 60 -	> 65 -	> 70	Total
Time	MPH	20 MPH	25 MPH	30 MPH	35 MPH	40 MPH	45 MPH	50 MPH	55 MPH	60 MPH	65 MPH	70 MPH	MPH	
12:00 AM	0	0	0	1	0	1	1	0	0	0	0	0	0	3
1:00	0	0	0	0	0	0	0	0	0	0	0	0	0	0
2:00	0	0	0	1	0	0	0	0	0	0	0	0	0	1
3:00	0	0	0	1	0	1	0	0	0	0	0	0	0	2
4:00	0	0	0	0	1	0	0	0	0	0	0	0	0	1
5:00	0	0	3	4	2	3	0	0	0	0	0	0	0	12
6:00	0	0	8	10	4	2	2	0	0	0	0	0	0	26
7:00	0	1	5	25	30	15	1	0	0	0	0	0	0	77
8:00	1	2	5	30	24	7	4	0	0	0	0	0	0	73
9:00	2	1	9	17	19	4	1	0	0	0	0	0	0	53
10:00	1	1	9	20	25	6	0	0	0	0	0	0	0	62
11:00	0	2	9	20	15	5	0	0	0	0	0	0	0	51
12:00 PM	0	0	13	18	24	3	1	0	0	0	0	0	0	59
1:00	3	2	9	16	21	6	2	1	0	0	0	0	0	60
2:00	0	1	6	29	35	11	1	0	0	0	0	0	0	83
3:00	2	2	10	33	26	14	4	1	0	0	0	0	0	92
4:00	2	2	12	18	21	14	4	0	0	0	0	0	0	73
5:00	0	3	8	27	23	10	1	0	0	0	0	0	0	72
6:00	0	0	4	18	13	4	1	0	0	0	0	0	0	40
7:00	1	0	8	8	4	1	1	0	0	0	0	0	0	23
8:00	0	1	5	3	3	4	0	0	0	0	0	0	0	16
9:00	0	0	2	1	2	1	0	0	0	0	0	0	0	6
10:00	0	0	2	4	3	1	0	0	0	0	0	0	0	10
11:00	0	0	0	1	1	1	0	0	0	0	0	0	0	3
Total	12	18	127	305	296	114	24	2	0	0	0	0	0	898

Project Name: Broad Rock Condos  
 Town / City, State: South Kingstown, RI  
 Roadway: Broad Rock Road  
 Location: at Woodmist Circle

**BETA Group, Inc.**  
 701 George Washington Highway  
 Lincoln, Rhode Island 02865  
 401.333.2382

Start Date: 4/17/2023  
 End Date: 4/25/2023

Direction: North, Lane 2

4/20/2023	0 - 15	> 15 -	> 20 -	> 25 -	> 30 -	> 35 -	> 40 -	> 45 -	> 50 -	> 55 -	> 60 -	> 65 -	> 70	Total
Time	MPH	20 MPH	25 MPH	30 MPH	35 MPH	40 MPH	45 MPH	50 MPH	55 MPH	60 MPH	65 MPH	70 MPH	MPH	
12:00 AM	0	0	0	0	0	0	0	0	0	0	0	0	0	0
1:00	0	0	0	1	0	0	0	0	0	0	0	0	0	1
2:00	0	0	1	0	0	0	0	0	0	0	0	0	0	1
3:00	0	0	0	1	0	0	0	0	0	0	0	0	0	1
4:00	0	1	0	0	0	0	0	0	0	0	0	0	0	1
5:00	1	0	2	4	2	2	0	0	0	0	0	0	0	11
6:00	0	0	5	13	10	3	2	0	0	0	0	0	0	33
7:00	0	0	5	15	28	7	2	0	0	0	0	0	0	57
8:00	0	0	6	27	28	14	2	1	1	0	0	0	0	79
9:00	0	0	11	12	17	8	3	0	0	0	0	0	0	51
10:00	1	0	11	10	14	10	0	0	0	0	0	0	0	46
11:00	1	0	8	20	11	4	1	0	0	0	0	0	0	45
12:00 PM	2	2	4	17	24	8	0	0	0	0	0	0	0	57
1:00	0	0	12	15	21	13	0	2	0	0	0	0	0	63
2:00	1	1	8	22	18	15	2	0	0	0	0	0	0	67
3:00	3	1	20	26	31	6	5	0	0	0	0	0	0	92
4:00	0	2	5	34	37	9	3	1	0	0	0	0	0	91
5:00	1	1	10	25	37	14	6	1	0	0	0	0	0	95
6:00	0	0	2	11	33	9	4	1	0	0	0	0	0	60
7:00	0	1	5	13	11	4	0	0	0	0	0	0	0	34
8:00	0	2	1	8	5	2	0	0	0	0	0	0	0	18
9:00	0	1	2	6	4	1	1	0	0	0	0	0	0	15
10:00	0	0	1	2	1	0	0	0	0	0	0	0	0	4
11:00	0	0	0	0	0	0	1	0	0	0	0	0	0	1
Total	10	12	119	282	332	129	32	6	1	0	0	0	0	923

Project Name: Broad Rock Condos  
 Town / City, State: South Kingstown, RI  
 Roadway: Broad Rock Road  
 Location: at Woodmist Circle

**BETA Group, Inc.**  
 701 George Washington Highway  
 Lincoln, Rhode Island 02865  
 401.333.2382

Start Date: 4/17/2023  
 End Date: 4/25/2023

Direction: North, Lane 2

4/21/2023	0 - 15	> 15 -	> 20 -	> 25 -	> 30 -	> 35 -	> 40 -	> 45 -	> 50 -	> 55 -	> 60 -	> 65 -	> 70	Total
Time	MPH	20 MPH	25 MPH	30 MPH	35 MPH	40 MPH	45 MPH	50 MPH	55 MPH	60 MPH	65 MPH	70 MPH	MPH	
12:00 AM	0	0	0	1	0	1	0	0	0	0	0	0	0	2
1:00	0	0	0	0	1	0	0	0	0	0	0	0	0	1
2:00	0	0	1	0	0	0	0	0	0	0	0	0	0	1
3:00	0	0	0	2	0	0	0	0	0	0	0	0	0	2
4:00	0	0	0	1	0	0	1	0	0	0	0	0	0	2
5:00	0	0	3	5	2	0	0	0	0	0	0	0	0	10
6:00	0	0	4	7	17	1	0	0	0	0	0	0	0	29
7:00	0	0	11	26	25	12	3	0	0	0	0	0	0	77
8:00	4	2	10	19	29	13	3	1	0	0	0	0	0	81
9:00	1	0	7	15	13	9	1	0	0	0	0	0	0	46
10:00	1	2	3	21	22	7	1	0	0	0	0	0	0	57
11:00	0	0	15	18	18	4	1	0	0	0	0	0	0	56
12:00 PM	2	0	8	23	17	12	0	0	0	0	0	0	0	62
1:00	0	2	6	28	31	16	1	0	0	0	0	0	0	84
2:00	0	0	12	17	22	14	2	0	0	0	0	0	0	67
3:00	1	3	9	30	40	20	5	0	0	0	0	0	0	108
4:00	0	2	10	32	29	14	9	0	0	0	0	0	0	96
5:00	0	1	4	21	39	19	1	0	1	0	0	0	0	86
6:00	1	1	8	17	23	10	1	0	0	0	0	0	0	61
7:00	0	1	4	6	6	6	2	0	0	1	0	0	0	26
8:00	0	0	1	5	7	1	0	0	0	0	0	0	0	14
9:00	2	3	0	8	2	0	0	0	0	0	0	0	0	15
10:00	0	0	1	3	0	0	1	0	0	0	0	0	0	5
11:00	0	0	0	4	4	0	0	0	0	0	0	0	0	8
Total	12	17	117	309	347	159	32	1	1	1	0	0	0	996

Project Name: Broad Rock Condos  
 Town / City, State: South Kingstown, RI  
 Roadway: Broad Rock Road  
 Location: at Woodmist Circle

**BETA Group, Inc.**  
 701 George Washington Highway  
 Lincoln, Rhode Island 02865  
 401.333.2382

Start Date: 4/17/2023  
 End Date: 4/25/2023

Direction: North, Lane 2

4/22/2023	0 - 15	> 15 -	> 20 -	> 25 -	> 30 -	> 35 -	> 40 -	> 45 -	> 50 -	> 55 -	> 60 -	> 65 -	> 70	Total
Time	MPH	20 MPH	25 MPH	30 MPH	35 MPH	40 MPH	45 MPH	50 MPH	55 MPH	60 MPH	65 MPH	70 MPH	MPH	
12:00 AM	0	0	0	3	2	0	0	0	0	0	0	0	0	5
1:00	0	0	0	2	1	0	0	0	0	0	0	0	0	3
2:00	0	0	0	0	0	0	0	0	0	0	0	0	0	0
3:00	0	0	0	1	1	0	0	0	0	0	0	0	0	2
4:00	0	0	0	1	0	0	0	0	0	0	0	0	0	1
5:00	1	0	1	3	3	0	0	0	0	0	0	0	0	8
6:00	0	1	3	4	2	0	0	0	0	0	0	0	0	10
7:00	0	0	8	5	10	5	1	0	0	0	0	0	0	29
8:00	1	0	10	15	11	14	1	0	0	0	0	0	0	52
9:00	0	2	7	18	17	7	4	0	0	0	0	0	0	55
10:00	2	1	9	21	20	11	2	0	0	0	0	0	0	66
11:00	1	2	8	16	16	6	2	0	0	0	0	0	0	51
12:00 PM	1	0	7	27	28	8	0	0	0	0	0	0	0	71
1:00	0	1	5	18	21	11	2	0	0	0	0	0	0	58
2:00	0	0	6	22	22	16	1	1	0	0	0	0	0	68
3:00	0	0	6	14	32	11	0	0	0	0	0	0	0	63
4:00	0	1	6	19	12	6	5	1	0	0	0	0	0	50
5:00	0	1	6	12	20	8	2	0	0	0	0	0	0	49
6:00	0	1	1	7	10	6	3	1	0	0	0	0	0	29
7:00	0	0	3	13	6	2	1	0	0	0	0	0	0	25
8:00	0	2	0	8	3	0	2	0	0	0	0	0	0	15
9:00	1	0	0	6	2	1	0	0	0	0	0	0	0	10
10:00	0	0	1	1	6	1	0	0	0	0	0	0	0	9
11:00	0	0	1	1	1	1	0	0	0	0	0	0	0	4
Total	7	12	88	237	246	114	26	3	0	0	0	0	0	733

Project Name: Broad Rock Condos  
 Town / City, State: South Kingstown, RI  
 Roadway: Broad Rock Road  
 Location: at Woodmist Circle

**BETA Group, Inc.**  
 701 George Washington Highway  
 Lincoln, Rhode Island 02865  
 401.333.2382

Start Date: 4/17/2023  
 End Date: 4/25/2023

Direction: North, Lane 2

4/23/2023	0 - 15	> 15 -	> 20 -	> 25 -	> 30 -	> 35 -	> 40 -	> 45 -	> 50 -	> 55 -	> 60 -	> 65 -	> 70	Total
Time	MPH	20 MPH	25 MPH	30 MPH	35 MPH	40 MPH	45 MPH	50 MPH	55 MPH	60 MPH	65 MPH	70 MPH	MPH	
12:00 AM	0	0	0	1	0	3	0	0	0	0	0	0	0	4
1:00	0	0	0	0	1	0	0	0	0	0	0	0	0	1
2:00	0	0	0	0	0	0	0	0	0	0	0	0	0	0
3:00	0	0	0	2	0	0	0	0	0	0	0	0	0	2
4:00	0	0	0	0	0	0	0	0	0	0	0	0	0	0
5:00	0	0	1	2	1	1	0	0	0	0	0	0	0	5
6:00	0	0	5	4	3	0	0	0	0	0	0	0	0	12
7:00	0	0	2	5	4	1	0	0	0	0	0	0	0	12
8:00	0	0	4	10	11	4	2	0	0	0	0	0	0	31
9:00	0	0	6	14	14	9	2	0	0	0	0	0	0	45
10:00	1	0	3	12	11	9	2	0	0	0	0	0	0	38
11:00	0	1	2	11	13	9	0	0	0	0	0	0	0	36
12:00 PM	0	0	0	20	19	17	2	1	0	0	0	0	0	59
1:00	0	1	5	10	11	10	5	0	0	0	0	0	0	42
2:00	0	0	4	13	13	7	0	0	0	0	0	0	0	37
3:00	0	0	5	14	9	11	2	2	0	0	0	1	0	44
4:00	0	0	2	14	10	4	4	1	0	0	0	0	0	35
5:00	0	1	4	8	11	7	1	0	1	0	0	0	0	33
6:00	0	0	0	7	8	7	1	0	1	0	0	0	0	24
7:00	1	0	3	6	5	0	0	0	0	0	0	0	0	15
8:00	0	0	3	5	0	1	0	0	0	0	0	0	0	9
9:00	0	0	1	7	3	3	0	0	0	0	0	0	0	14
10:00	0	0	0	0	1	0	1	0	0	0	0	0	0	2
11:00	0	0	0	0	1	0	0	0	0	0	0	0	0	1
Total	2	3	50	165	149	103	22	4	2	0	0	1	0	501

Project Name: Broad Rock Condos  
 Town / City, State: South Kingstown, RI  
 Roadway: Broad Rock Road  
 Location: at Woodmist Circle

**BETA Group, Inc.**  
 701 George Washington Highway  
 Lincoln, Rhode Island 02865  
 401.333.2382

Start Date: 4/17/2023  
 End Date: 4/25/2023

Direction: North, Lane 2

4/24/2023	0 - 15	> 15 -	> 20 -	> 25 -	> 30 -	> 35 -	> 40 -	> 45 -	> 50 -	> 55 -	> 60 -	> 65 -	> 70	Total
Time	MPH	20 MPH	25 MPH	30 MPH	35 MPH	40 MPH	45 MPH	50 MPH	55 MPH	60 MPH	65 MPH	70 MPH	MPH	
12:00 AM	0	0	0	0	0	0	0	0	0	0	0	0	0	0
1:00	0	0	0	0	1	0	0	0	0	0	0	0	0	1
2:00	0	0	0	0	0	0	0	0	0	0	0	0	0	0
3:00	0	0	0	0	1	0	0	0	0	0	0	0	0	1
4:00	0	0	1	1	1	0	0	0	0	0	0	0	0	3
5:00	0	1	2	6	4	1	0	0	0	0	0	0	0	14
6:00	0	0	1	9	10	2	0	0	0	0	0	0	0	22
7:00	0	0	3	23	17	8	4	0	0	0	0	0	0	55
8:00	4	3	10	28	26	12	2	1	0	0	0	0	0	86
9:00	0	0	10	14	18	4	1	2	0	0	0	0	0	49
10:00	0	1	5	26	17	3	1	0	0	0	0	0	0	53
11:00	0	1	3	17	19	7	1	1	0	0	0	0	0	49
12:00 PM	0	1	7	21	18	9	5	0	0	0	0	0	0	61
1:00	3	1	4	13	28	3	2	2	0	0	0	0	0	56
2:00	0	0	7	16	30	12	5	0	0	0	0	0	0	70
3:00	2	3	15	30	28	15	0	1	0	0	0	0	0	94
4:00	2	4	11	28	30	17	2	0	0	0	0	0	0	94
5:00	2	1	7	21	43	6	0	0	0	1	0	0	0	81
6:00	0	0	2	16	13	7	2	0	0	0	0	0	0	40
7:00	1	0	6	5	8	2	0	0	0	0	0	0	0	22
8:00	0	0	2	6	2	0	0	0	0	0	0	0	0	10
9:00	0	1	0	0	3	1	0	0	0	0	0	0	0	5
10:00	0	0	1	2	2	0	1	0	0	0	0	0	0	6
11:00	0	0	1	3	1	0	0	0	0	0	0	0	0	5
<b>Total</b>	<b>14</b>	<b>17</b>	<b>98</b>	<b>285</b>	<b>320</b>	<b>109</b>	<b>26</b>	<b>7</b>	<b>0</b>	<b>1</b>	<b>0</b>	<b>0</b>	<b>0</b>	<b>877</b>

Project Name: Broad Rock Condos  
 Town / City, State: South Kingstown, RI  
 Roadway: Broad Rock Road  
 Location: at Woodmist Circle

**BETA Group, Inc.**  
 701 George Washington Highway  
 Lincoln, Rhode Island 02865  
 401.333.2382

Start Date: 4/17/2023  
 End Date: 4/25/2023

Direction: North, Lane 2

4/25/2023 Time	0 - 15 MPH	> 15 - 20 MPH	> 20 - 25 MPH	> 25 - 30 MPH	> 30 - 35 MPH	> 35 - 40 MPH	> 40 - 45 MPH	> 45 - 50 MPH	> 50 - 55 MPH	> 55 - 60 MPH	> 60 - 65 MPH	> 65 - 70 MPH	> 70 MPH	Total
12:00 AM	0	0	1	1	0	0	0	0	0	0	0	0	0	2
1:00	0	0	0	0	0	0	0	0	0	0	0	0	0	0
2:00	0	0	0	0	0	0	0	0	0	0	0	0	0	0
3:00	1	0	0	1	1	0	0	0	0	0	0	0	0	3
4:00	0	0	1	0	1	0	0	0	0	0	0	0	0	2
5:00	1	1	1	5	2	2	1	0	0	0	0	0	0	13
6:00	0	1	3	8	12	5	0	0	0	0	0	0	0	29
7:00	0	1	7	19	15	4	2	1	0	0	0	0	0	49
8:00	1	4	6	12	18	6	3	0	0	0	0	0	0	50
9:00	0	0	0	1	0	0	1	0	0	2	7	8	1	20
10:00	*	*	*	*	*	*	*	*	*	*	*	*	*	0
11:00	*	*	*	*	*	*	*	*	*	*	*	*	*	0
12:00 PM	*	*	*	*	*	*	*	*	*	*	*	*	*	0
1:00	*	*	*	*	*	*	*	*	*	*	*	*	*	0
2:00	*	*	*	*	*	*	*	*	*	*	*	*	*	0
3:00	*	*	*	*	*	*	*	*	*	*	*	*	*	0
4:00	*	*	*	*	*	*	*	*	*	*	*	*	*	0
5:00	*	*	*	*	*	*	*	*	*	*	*	*	*	0
6:00	*	*	*	*	*	*	*	*	*	*	*	*	*	0
7:00	*	*	*	*	*	*	*	*	*	*	*	*	*	0
8:00	*	*	*	*	*	*	*	*	*	*	*	*	*	0
9:00	*	*	*	*	*	*	*	*	*	*	*	*	*	0
10:00	*	*	*	*	*	*	*	*	*	*	*	*	*	0
11:00	*	*	*	*	*	*	*	*	*	*	*	*	*	0
<b>Total</b>	<b>3</b>	<b>7</b>	<b>19</b>	<b>47</b>	<b>49</b>	<b>17</b>	<b>7</b>	<b>1</b>	<b>0</b>	<b>2</b>	<b>7</b>	<b>8</b>	<b>1</b>	<b>168</b>
<b>Grand Total</b>	<b>74</b>	<b>106</b>	<b>764</b>	<b>2020</b>	<b>2124</b>	<b>920</b>	<b>214</b>	<b>30</b>	<b>4</b>	<b>4</b>	<b>7</b>	<b>9</b>	<b>1</b>	<b>6277</b>

Stats	Percentile	15th
	Speed	25
		30
		36
		39
	Mean Speed (Average)	30.5
	10 MPH Pace Speed	25-34
	Number in Pace	4117
	Percent in Pace	65.6%
	Number > 25 MPH	5333
	Percent > 25 MPH	85.0%

A

Intersection Turning Movement Count

Broad Rock Road at Saugatucket Road

Broad Rock Road at Saugatucket Road

PDI File #: **239193 A**  
 Location: **N: Broad Rock Road S: Broad Rock Road**  
 Location: **E: Saugatucket Road W: Saugatucket Road**  
 City, State: **South Kingstown, RI**  
 Client: **BETA/ E. Beaudry**  
 Site Code: **10731**  
 Count Date: **Thursday, April 20, 2023**  
 Start Time: **7:00 AM**  
 End Time: **9:00 AM**  
 Class:



**Cars and Heavy Vehicles (Combined)**

	Broad Rock Road					Saugatucket Road					Broad Rock Road					Saugatucket Road					Total
	from North					from East					from South					from West					
	Right	Thru	Left	U-Turn	Total	Right	Thru	Left	U-Turn	Total	Right	Thru	Left	U-Turn	Total	Right	Thru	Left	U-Turn	Total	
7:00 AM	3	7	0	0	10	0	29	13	0	42	0	13	6	0	19	19	12	4	0	35	106
7:15 AM	8	14	0	0	22	1	28	14	0	43	6	20	20	0	46	63	8	5	0	76	187
7:30 AM	2	8	4	0	14	1	24	15	0	40	7	22	40	0	69	18	16	3	0	37	160
7:45 AM	3	11	5	0	19	0	25	12	0	37	4	12	7	0	23	11	30	5	0	46	125
<b>Total</b>	<b>16</b>	<b>40</b>	<b>9</b>	<b>0</b>	<b>65</b>	<b>2</b>	<b>106</b>	<b>54</b>	<b>0</b>	<b>162</b>	<b>17</b>	<b>67</b>	<b>73</b>	<b>0</b>	<b>157</b>	<b>111</b>	<b>66</b>	<b>17</b>	<b>0</b>	<b>194</b>	<b>578</b>
8:00 AM	5	10	7	0	22	2	28	7	0	37	1	17	4	0	22	6	9	8	0	23	104
8:15 AM	4	9	5	0	18	2	35	10	0	47	1	14	6	0	21	9	17	4	0	30	116
8:30 AM	3	14	6	0	23	3	27	9	0	39	3	18	11	0	32	7	13	6	0	26	120
8:45 AM	11	13	3	0	27	1	26	13	0	40	2	12	6	0	20	15	16	7	0	38	125
<b>Total</b>	<b>23</b>	<b>46</b>	<b>21</b>	<b>0</b>	<b>90</b>	<b>8</b>	<b>116</b>	<b>39</b>	<b>0</b>	<b>163</b>	<b>7</b>	<b>61</b>	<b>27</b>	<b>0</b>	<b>95</b>	<b>37</b>	<b>55</b>	<b>25</b>	<b>0</b>	<b>117</b>	<b>465</b>
Grand Total	39	86	30	0	155	10	222	93	0	325	24	128	100	0	252	148	121	42	0	311	1043
Approach %	25.2	55.5	19.4	0.0		3.1	68.3	28.6	0.0		9.5	50.8	39.7	0.0		47.6	38.9	13.5	0.0		
Total %	3.7	8.2	2.9	0.0	14.9	1.0	21.3	8.9	0.0	31.2	2.3	12.3	9.6	0.0	24.2	14.2	11.6	4.0	0.0	29.8	
Exiting Leg Total	180					175					327					361					1043
Cars	38	85	29	0	152	10	201	92	0	303	24	125	92	0	241	132	115	41	0	288	984
% Cars	97.4	98.8	96.7	0.0	98.1	100.0	90.5	98.9	0.0	93.2	100.0	97.7	92.0	0.0	95.6	89.2	95.0	97.6	0.0	92.6	94.3
Exiting Leg Total	176					168					309					331					984
Heavy Vehicles	1	1	1	0	3	0	21	1	0	22	0	3	8	0	11	16	6	1	0	23	59
% Heavy Vehicles	2.6	1.2	3.3	0.0	1.9	0.0	9.5	1.1	0.0	6.8	0.0	2.3	8.0	0.0	4.4	10.8	5.0	2.4	0.0	7.4	5.7
Exiting Leg Total	4					7					18					30					59

Peak Hour Analysis from 07:00 AM to 09:00 AM begins at:

7:00 AM	Broad Rock Road					Saugatucket Road					Broad Rock Road					Saugatucket Road					Total
	from North					from East					from South					from West					
	Right	Thru	Left	U-Turn	Total	Right	Thru	Left	U-Turn	Total	Right	Thru	Left	U-Turn	Total	Right	Thru	Left	U-Turn	Total	
7:00 AM	3	7	0	0	10	0	29	13	0	42	0	13	6	0	19	19	12	4	0	35	106
7:15 AM	8	14	0	0	22	1	28	14	0	43	6	20	20	0	46	63	8	5	0	76	187
7:30 AM	2	8	4	0	14	1	24	15	0	40	7	22	40	0	69	18	16	3	0	37	160
7:45 AM	3	11	5	0	19	0	25	12	0	37	4	12	7	0	23	11	30	5	0	46	125
Total Volume	16	40	9	0	65	2	106	54	0	162	17	67	73	0	157	111	66	17	0	194	578
% Approach Total	24.6	61.5	13.8	0.0		1.2	65.4	33.3	0.0		10.8	42.7	46.5	0.0		57.2	34.0	8.8	0.0		
PHF	0.500	0.714	0.450	0.000	0.739	0.500	0.914	0.900	0.000	0.942	0.607	0.761	0.456	0.000	0.569	0.440	0.550	0.850	0.000	0.638	0.773
Cars	15	39	9	0	63	2	97	53	0	152	17	66	65	0	148	97	61	17	0	175	538
Cars %	93.8	97.5	100.0	0.0	96.9	100.0	91.5	98.1	0.0	93.8	100.0	98.5	89.0	0.0	94.3	87.4	92.4	100.0	0.0	90.2	93.1
Heavy Vehicles	1	1	0	0	2	0	9	1	0	10	0	1	8	0	9	14	5	0	0	19	40
Heavy Vehicles %	6.3	2.5	0.0	0.0	3.1	0.0	8.5	1.9	0.0	6.2	0.0	1.5	11.0	0.0	5.7	12.6	7.6	0.0	0.0	9.8	6.9
Cars Enter Leg	15	39	9	0	63	2	97	53	0	152	17	66	65	0	148	97	61	17	0	175	538
Heavy Enter Leg	1	1	0	0	2	0	9	1	0	10	0	1	8	0	9	14	5	0	0	19	40
Total Entering Leg	16	40	9	0	65	2	106	54	0	162	17	67	73	0	157	111	66	17	0	194	578
Cars Exiting Leg	85					87					189					177					538
Heavy Exiting Leg	1					5					16					18					40
Total Exiting Leg	86					92					205					195					578

PDI File #: **239193 A**  
 Location: **N: Broad Rock Road S: Broad Rock Road**  
 Location: **E: Saugatucket Road W: Saugatucket Road**  
 City, State: **South Kingstown, RI**  
 Client: **BETA/ E. Beaudry**  
 Site Code: **10731**  
 Count Date: **Thursday, April 20, 2023**  
 Start Time: **7:00 AM**  
 End Time: **9:00 AM**  
 Class:



**Cars**

	Broad Rock Road					Saugatucket Road					Broad Rock Road					Saugatucket Road					Total
	from North					from East					from South					from West					
	Right	Thru	Left	U-Turn	Total	Right	Thru	Left	U-Turn	Total	Right	Thru	Left	U-Turn	Total	Right	Thru	Left	U-Turn	Total	
7:00 AM	3	6	0	0	9	0	26	13	0	39	0	13	5	0	18	19	10	4	0	33	99
7:15 AM	8	14	0	0	22	1	27	14	0	42	6	20	14	0	40	51	8	5	0	64	168
7:30 AM	1	8	4	0	13	1	23	15	0	39	7	21	40	0	68	18	14	3	0	35	155
7:45 AM	3	11	5	0	19	0	21	11	0	32	4	12	6	0	22	9	29	5	0	43	116
<b>Total</b>	<b>15</b>	<b>39</b>	<b>9</b>	<b>0</b>	<b>63</b>	<b>2</b>	<b>97</b>	<b>53</b>	<b>0</b>	<b>152</b>	<b>17</b>	<b>66</b>	<b>65</b>	<b>0</b>	<b>148</b>	<b>97</b>	<b>61</b>	<b>17</b>	<b>0</b>	<b>175</b>	<b>538</b>
8:00 AM	5	10	7	0	22	2	27	7	0	36	1	16	4	0	21	6	9	7	0	22	101
8:15 AM	4	9	5	0	18	2	31	10	0	43	1	13	6	0	20	8	17	4	0	29	110
8:30 AM	3	14	5	0	22	3	23	9	0	35	3	18	11	0	32	6	12	6	0	24	113
8:45 AM	11	13	3	0	27	1	23	13	0	37	2	12	6	0	20	15	16	7	0	38	122
<b>Total</b>	<b>23</b>	<b>46</b>	<b>20</b>	<b>0</b>	<b>89</b>	<b>8</b>	<b>104</b>	<b>39</b>	<b>0</b>	<b>151</b>	<b>7</b>	<b>59</b>	<b>27</b>	<b>0</b>	<b>93</b>	<b>35</b>	<b>54</b>	<b>24</b>	<b>0</b>	<b>113</b>	<b>446</b>
Grand Total	38	85	29	0	152	10	201	92	0	303	24	125	92	0	241	132	115	41	0	288	984
Approach %	25.0	55.9	19.1	0.0		3.3	66.3	30.4	0.0		10.0	51.9	38.2	0.0		45.8	39.9	14.2	0.0		
Total %	3.9	8.6	2.9	0.0	15.4	1.0	20.4	9.3	0.0	30.8	2.4	12.7	9.3	0.0	24.5	13.4	11.7	4.2	0.0	29.3	
Exiting Leg Total	176					168					309					331					984

Peak Hour Analysis from 07:00 AM to 09:00 AM begins at:

	Broad Rock Road					Saugatucket Road					Broad Rock Road					Saugatucket Road					Total
	from North					from East					from South					from West					
	Right	Thru	Left	U-Turn	Total	Right	Thru	Left	U-Turn	Total	Right	Thru	Left	U-Turn	Total	Right	Thru	Left	U-Turn	Total	
7:15 AM	8	14	0	0	22	1	27	14	0	42	6	20	14	0	40	51	8	5	0	64	168
7:30 AM	1	8	4	0	13	1	23	15	0	39	7	21	40	0	68	18	14	3	0	35	155
7:45 AM	3	11	5	0	19	0	21	11	0	32	4	12	6	0	22	9	29	5	0	43	116
8:00 AM	5	10	7	0	22	2	27	7	0	36	1	16	4	0	21	6	9	7	0	22	101
Total Volume	17	43	16	0	76	4	98	47	0	149	18	69	64	0	151	84	60	20	0	164	540
% Approach Total	22.4	56.6	21.1	0.0		2.7	65.8	31.5	0.0		11.9	45.7	42.4	0.0		51.2	36.6	12.2	0.0		
PHF	0.531	0.768	0.571	0.000	0.864	0.500	0.907	0.783	0.000	0.887	0.643	0.821	0.400	0.000	0.555	0.412	0.517	0.714	0.000	0.641	0.804
Entering Leg	17	43	16	0	76	4	98	47	0	149	18	69	64	0	151	84	60	20	0	164	540
Exiting Leg	93					94					174					179					540
Total	169					243					325					343					1080

PDI File #: **239193 A**  
 Location: **N: Broad Rock Road S: Broad Rock Road**  
 Location: **E: Saugatucket Road W: Saugatucket Road**  
 City, State: **South Kingstown, RI**  
 Client: **BETA/ E. Beaudry**  
 Site Code: **10731**  
 Count Date: **Thursday, April 20, 2023**  
 Start Time: **7:00 AM**  
 End Time: **9:00 AM**



**Heavy Vehicles-Combined (Buses, Single-Unit Trucks, Articulated Trucks)**

	Broad Rock Road					Saugatucket Road					Broad Rock Road					Saugatucket Road					Total
	from North					from East					from South					from West					
	Right	Thru	Left	U-Turn	Total	Right	Thru	Left	U-Turn	Total	Right	Thru	Left	U-Turn	Total	Right	Thru	Left	U-Turn	Total	
7:00 AM	0	1	0	0	1	0	3	0	0	3	0	0	1	0	1	0	2	0	0	2	7
7:15 AM	0	0	0	0	0	0	1	0	0	1	0	0	6	0	6	12	0	0	0	12	19
7:30 AM	1	0	0	0	1	0	1	0	0	1	0	1	0	0	1	0	2	0	0	2	5
7:45 AM	0	0	0	0	0	0	4	1	0	5	0	0	1	0	1	2	1	0	0	3	9
<b>Total</b>	<b>1</b>	<b>1</b>	<b>0</b>	<b>0</b>	<b>2</b>	<b>0</b>	<b>9</b>	<b>1</b>	<b>0</b>	<b>10</b>	<b>0</b>	<b>1</b>	<b>8</b>	<b>0</b>	<b>9</b>	<b>14</b>	<b>5</b>	<b>0</b>	<b>0</b>	<b>19</b>	<b>40</b>
8:00 AM	0	0	0	0	0	0	1	0	0	1	0	1	0	0	1	0	0	1	0	1	3
8:15 AM	0	0	0	0	0	0	4	0	0	4	0	1	0	0	1	1	0	0	0	1	6
8:30 AM	0	0	1	0	1	0	4	0	0	4	0	0	0	0	0	1	1	0	0	2	7
8:45 AM	0	0	0	0	0	0	3	0	0	3	0	0	0	0	0	0	0	0	0	0	3
<b>Total</b>	<b>0</b>	<b>0</b>	<b>1</b>	<b>0</b>	<b>1</b>	<b>0</b>	<b>12</b>	<b>0</b>	<b>0</b>	<b>12</b>	<b>0</b>	<b>2</b>	<b>0</b>	<b>0</b>	<b>2</b>	<b>2</b>	<b>1</b>	<b>1</b>	<b>0</b>	<b>4</b>	<b>19</b>
Grand Total	1	1	1	0	3	0	21	1	0	22	0	3	8	0	11	16	6	1	0	23	59
Approach %	33.3	33.3	33.3	0.0		0.0	95.5	4.5	0.0		0.0	27.3	72.7	0.0		69.6	26.1	4.3	0.0		
Total %	1.7	1.7	1.7	0.0	5.1	0.0	35.6	1.7	0.0	37.3	0.0	5.1	13.6	0.0	18.6	27.1	10.2	1.7	0.0	39.0	
Exiting Leg Total	4					7					18					30					59
Buses	0	1	1	0	2	0	6	1	0	7	0	1	8	0	9	16	3	1	0	20	38
% Buses	0.0	100.0	100.0	0.0	66.7	0.0	28.6	100.0	0.0	31.8	0.0	33.3	100.0	0.0	81.8	100.0	50.0	100.0	0.0	87.0	64.4
Exiting Leg Total	2					4					18					14					38
Single-Unit Trucks	1	0	0	0	1	0	12	0	0	12	0	2	0	0	2	0	3	0	0	3	18
% Single-Unit	100.0	0.0	0.0	0.0	33.3	0.0	57.1	0.0	0.0	54.5	0.0	66.7	0.0	0.0	18.2	0.0	50.0	0.0	0.0	13.0	30.5
Exiting Leg Total	2					3					0					13					18
Articulated Trucks	0	0	0	0	0	0	3	0	0	3	0	0	0	0	0	0	0	0	0	0	3
% Articulated	0.0	0.0	0.0	0.0	0.0	0.0	14.3	0.0	0.0	13.6	0.0	0.0	0.0	0.0	0.0	0.0	0.0	0.0	0.0	0.0	5.1
Exiting Leg Total	0					0					0					3					3

**Peak Hour Analysis from 07:00 AM to 09:00 AM begins at:**

	Broad Rock Road					Saugatucket Road					Broad Rock Road					Saugatucket Road					Total
	from North					from East					from South					from West					
	Right	Thru	Left	U-Turn	Total	Right	Thru	Left	U-Turn	Total	Right	Thru	Left	U-Turn	Total	Right	Thru	Left	U-Turn	Total	
7:00 AM	0	1	0	0	1	0	3	0	0	3	0	0	1	0	1	0	2	0	0	2	7
7:15 AM	0	0	0	0	0	0	1	0	0	1	0	0	6	0	6	12	0	0	0	12	19
7:30 AM	1	0	0	0	1	0	1	0	0	1	0	1	0	0	1	0	2	0	0	2	5
7:45 AM	0	0	0	0	0	0	4	1	0	5	0	0	1	0	1	2	1	0	0	3	9
<b>Total Volume</b>	<b>1</b>	<b>1</b>	<b>0</b>	<b>0</b>	<b>2</b>	<b>0</b>	<b>9</b>	<b>1</b>	<b>0</b>	<b>10</b>	<b>0</b>	<b>1</b>	<b>8</b>	<b>0</b>	<b>9</b>	<b>14</b>	<b>5</b>	<b>0</b>	<b>0</b>	<b>19</b>	<b>40</b>
% Approach Total	50.0	50.0	0.0	0.0		0.0	90.0	10.0	0.0		0.0	11.1	88.9	0.0		73.7	26.3	0.0	0.0		
PHF	0.250	0.250	0.000	0.000	0.500	0.000	0.563	0.250	0.000	0.500	0.000	0.250	0.333	0.000	0.375	0.292	0.625	0.000	0.000	0.396	0.526
Buses	0	1	0	0	1	0	2	1	0	3	0	0	8	0	8	14	3	0	0	17	29
Buses %	0.0	100.0	0.0	0.0	50.0	0.0	22.2	100.0	0.0	30.0	0.0	0.0	100.0	0.0	88.9	100.0	60.0	0.0	0.0	89.5	72.5
Single-Unit Trucks	1	0	0	0	1	0	6	0	0	6	0	1	0	0	1	0	2	0	0	2	10
Single-Unit %	100.0	0.0	0.0	0.0	50.0	0.0	66.7	0.0	0.0	60.0	0.0	100.0	0.0	0.0	11.1	0.0	40.0	0.0	0.0	10.5	25.0
Articulated Trucks	0	0	0	0	0	0	1	0	0	1	0	0	0	0	0	0	0	0	0	0	1
Articulated %	0.0	0.0	0.0	0.0	0.0	0.0	11.1	0.0	0.0	10.0	0.0	0.0	0.0	0.0	0.0	0.0	0.0	0.0	0.0	0.0	2.5
Buses	0	1	0	0	1	0	2	1	0	3	0	0	8	0	8	14	3	0	0	17	29
Single-Unit Trucks	1	0	0	0	1	0	6	0	0	6	0	1	0	0	1	0	2	0	0	2	10
Articulated Trucks	0	0	0	0	0	0	1	0	0	1	0	0	0	0	0	0	0	0	0	0	1
<b>Total Entering Leg</b>	<b>1</b>	<b>1</b>	<b>0</b>	<b>0</b>	<b>2</b>	<b>0</b>	<b>9</b>	<b>1</b>	<b>0</b>	<b>10</b>	<b>0</b>	<b>1</b>	<b>8</b>	<b>0</b>	<b>9</b>	<b>14</b>	<b>5</b>	<b>0</b>	<b>0</b>	<b>19</b>	<b>40</b>
Buses	0					3					16					10					29
Single-Unit Trucks	1					2					0					7					10
Articulated Trucks	0					0					0					1					1
<b>Total Exiting Leg</b>	<b>1</b>					<b>5</b>					<b>16</b>					<b>18</b>					<b>40</b>

PDI File #: **239193 A**  
 Location: **N: Broad Rock Road S: Broad Rock Road**  
 Location: **E: Saugatucket Road W: Saugatucket Road**  
 City, State: **South Kingstown, RI**  
 Client: **BETA/ E. Beaudry**  
 Site Code: **10731**  
 Count Date: **Thursday, April 20, 2023**  
 Start Time: **7:00 AM**  
 End Time: **9:00 AM**  
 Class:



**Buses**

	Broad Rock Road					Saugatucket Road					Broad Rock Road					Saugatucket Road					Total	
	from North					from East					from South					from West						
	Right	Thru	Left	U-Turn	Total	Right	Thru	Left	U-Turn	Total	Right	Thru	Left	U-Turn	Total	Right	Thru	Left	U-Turn	Total		
7:00 AM	0	1	0	0	1	0	2	0	0	2	0	0	1	0	1	0	0	0	0	0	4	
7:15 AM	0	0	0	0	0	0	0	0	0	0	0	0	6	0	6	12	0	0	0	12	18	
7:30 AM	0	0	0	0	0	0	0	0	0	0	0	0	0	0	0	0	2	0	0	2	2	
7:45 AM	0	0	0	0	0	0	0	1	0	1	0	0	1	0	1	2	1	0	0	3	5	
<b>Total</b>	<b>0</b>	<b>1</b>	<b>0</b>	<b>0</b>	<b>1</b>	<b>0</b>	<b>2</b>	<b>1</b>	<b>0</b>	<b>3</b>	<b>0</b>	<b>0</b>	<b>8</b>	<b>0</b>	<b>8</b>	<b>14</b>	<b>3</b>	<b>0</b>	<b>0</b>	<b>17</b>	<b>29</b>	
8:00 AM	0	0	0	0	0	0	1	0	0	1	0	1	0	0	1	0	0	1	0	1	3	
8:15 AM	0	0	0	0	0	0	1	0	0	1	0	0	0	0	0	1	0	0	0	1	2	
8:30 AM	0	0	1	0	1	0	0	0	0	0	0	0	0	0	0	1	0	0	0	1	2	
8:45 AM	0	0	0	0	0	0	2	0	0	2	0	0	0	0	0	0	0	0	0	0	2	
<b>Total</b>	<b>0</b>	<b>0</b>	<b>1</b>	<b>0</b>	<b>1</b>	<b>0</b>	<b>4</b>	<b>0</b>	<b>0</b>	<b>4</b>	<b>0</b>	<b>1</b>	<b>0</b>	<b>0</b>	<b>1</b>	<b>2</b>	<b>0</b>	<b>1</b>	<b>0</b>	<b>3</b>	<b>9</b>	
Grand Total	0	1	1	0	2	0	6	1	0	7	0	1	8	0	9	16	3	1	0	20	38	
Approach %	0.0	50.0	50.0	0.0		0.0	85.7	14.3	0.0		0.0	11.1	88.9	0.0		80.0	15.0	5.0	0.0			
Total %	0.0	2.6	2.6	0.0	5.3	0.0	15.8	2.6	0.0	18.4	0.0	2.6	21.1	0.0	23.7	42.1	7.9	2.6	0.0	52.6		
Exiting Leg Total						2					4					18					14	38

Peak Hour Analysis from 07:00 AM to 09:00 AM begins at:

	Broad Rock Road					Saugatucket Road					Broad Rock Road					Saugatucket Road					Total	
	from North					from East					from South					from West						
	Right	Thru	Left	U-Turn	Total	Right	Thru	Left	U-Turn	Total	Right	Thru	Left	U-Turn	Total	Right	Thru	Left	U-Turn	Total		
7:00 AM	0	1	0	0	1	0	2	0	0	2	0	0	1	0	1	0	0	0	0	0	4	
7:15 AM	0	0	0	0	0	0	0	0	0	0	0	0	6	0	6	12	0	0	0	12	18	
7:30 AM	0	0	0	0	0	0	0	0	0	0	0	0	0	0	0	0	2	0	0	2	2	
7:45 AM	0	0	0	0	0	0	0	1	0	1	0	0	1	0	1	2	1	0	0	3	5	
Total Volume	0	1	0	0	1	0	2	1	0	3	0	0	8	0	8	14	3	0	0	17	29	
% Approach Total	0.0	100.0	0.0	0.0		0.0	66.7	33.3	0.0		0.0	0.0	100.0	0.0		82.4	17.6	0.0	0.0			
PHF	0.000	0.250	0.000	0.000	0.250	0.000	0.250	0.250	0.000	0.375	0.000	0.000	0.333	0.000	0.333	0.292	0.375	0.000	0.000	0.354	0.403	
Entering Leg	0	1	0	0	1	0	2	1	0	3	0	0	8	0	8	14	3	0	0	17	29	
Exiting Leg						0					3					16					10	29
Total						1					6					24					27	58

PDI File #: **239193 A**  
 Location: **N: Broad Rock Road S: Broad Rock Road**  
 Location: **E: Saugatucket Road W: Saugatucket Road**  
 City, State: **South Kingstown, RI**  
 Client: **BETA/ E. Beaudry**  
 Site Code: **10731**  
 Count Date: **Thursday, April 20, 2023**  
 Start Time: **7:00 AM**  
 End Time: **9:00 AM**  
 Class:



**Single-Unit Trucks**

	Broad Rock Road					Saugatucket Road					Broad Rock Road					Saugatucket Road					Total	
	from North					from East					from South					from West						
	Right	Thru	Left	U-Turn	Total	Right	Thru	Left	U-Turn	Total	Right	Thru	Left	U-Turn	Total	Right	Thru	Left	U-Turn	Total		
7:00 AM	0	0	0	0	0	0	1	0	0	1	0	0	0	0	0	0	2	0	0	2	3	
7:15 AM	0	0	0	0	0	0	1	0	0	1	0	0	0	0	0	0	0	0	0	0	1	
7:30 AM	1	0	0	0	1	0	0	0	0	0	0	1	0	0	1	0	0	0	0	0	2	
7:45 AM	0	0	0	0	0	0	4	0	0	4	0	0	0	0	0	0	0	0	0	0	4	
<b>Total</b>	<b>1</b>	<b>0</b>	<b>0</b>	<b>0</b>	<b>1</b>	<b>0</b>	<b>6</b>	<b>0</b>	<b>0</b>	<b>6</b>	<b>0</b>	<b>1</b>	<b>0</b>	<b>0</b>	<b>1</b>	<b>0</b>	<b>2</b>	<b>0</b>	<b>0</b>	<b>2</b>	<b>10</b>	
8:00 AM	0	0	0	0	0	0	0	0	0	0	0	0	0	0	0	0	0	0	0	0	0	
8:15 AM	0	0	0	0	0	0	3	0	0	3	0	1	0	0	1	0	0	0	0	0	4	
8:30 AM	0	0	0	0	0	0	2	0	0	2	0	0	0	0	0	0	1	0	0	1	3	
8:45 AM	0	0	0	0	0	0	1	0	0	1	0	0	0	0	0	0	0	0	0	0	1	
<b>Total</b>	<b>0</b>	<b>0</b>	<b>0</b>	<b>0</b>	<b>0</b>	<b>0</b>	<b>6</b>	<b>0</b>	<b>0</b>	<b>6</b>	<b>0</b>	<b>1</b>	<b>0</b>	<b>0</b>	<b>1</b>	<b>0</b>	<b>1</b>	<b>0</b>	<b>0</b>	<b>1</b>	<b>8</b>	
Grand Total	1	0	0	0	1	0	12	0	0	12	0	2	0	0	2	0	3	0	0	3	18	
Approach %	100.0	0.0	0.0	0.0		0.0	100.0	0.0	0.0		0.0	100.0	0.0	0.0		0.0	100.0	0.0	0.0			
Total %	5.6	0.0	0.0	0.0	5.6	0.0	66.7	0.0	0.0	66.7	0.0	11.1	0.0	0.0	11.1	0.0	16.7	0.0	0.0	16.7		
Exiting Leg Total						2					3					0					13	18

Peak Hour Analysis from 07:00 AM to 09:00 AM begins at:

	Broad Rock Road					Saugatucket Road					Broad Rock Road					Saugatucket Road					Total	
	from North					from East					from South					from West						
	Right	Thru	Left	U-Turn	Total	Right	Thru	Left	U-Turn	Total	Right	Thru	Left	U-Turn	Total	Right	Thru	Left	U-Turn	Total		
7:45 AM	0	0	0	0	0	0	4	0	0	4	0	0	0	0	0	0	0	0	0	0	4	
7:45 AM	0	0	0	0	0	0	0	0	0	0	0	0	0	0	0	0	0	0	0	0	0	
8:00 AM	0	0	0	0	0	0	3	0	0	3	0	1	0	0	1	0	0	0	0	0	4	
8:15 AM	0	0	0	0	0	0	2	0	0	2	0	0	0	0	0	0	1	0	0	1	3	
8:30 AM	0	0	0	0	0	0	2	0	0	2	0	0	0	0	0	0	1	0	0	1	3	
Total Volume	0	0	0	0	0	0	9	0	0	9	0	1	0	0	1	0	1	0	0	1	11	
% Approach Total	0.0	0.0	0.0	0.0		0.0	100.0	0.0	0.0		0.0	100.0	0.0	0.0		0.0	100.0	0.0	0.0			
PHF	0.000	0.000	0.000	0.000	0.000	0.000	0.563	0.000	0.000	0.563	0.000	0.250	0.000	0.000	0.250	0.000	0.250	0.000	0.000	0.250	0.688	
Entering Leg	0	0	0	0	0	0	9	0	0	9	0	1	0	0	1	0	1	0	0	1	11	
Exiting Leg						1					1					0					9	11
Total						1					10					1					10	22

PDI File #: **239193 A**  
 Location: **N: Broad Rock Road S: Broad Rock Road**  
 Location: **E: Saugatucket Road W: Saugatucket Road**  
 City, State: **South Kingstown, RI**  
 Client: **BETA/ E. Beaudry**  
 Site Code: **10731**  
 Count Date: **Thursday, April 20, 2023**  
 Start Time: **7:00 AM**  
 End Time: **9:00 AM**  
 Class:



**Articulated Trucks**

	Broad Rock Road					Saugatucket Road					Broad Rock Road					Saugatucket Road					Total
	from North					from East					from South					from West					
	Right	Thru	Left	U-Turn	Total	Right	Thru	Left	U-Turn	Total	Right	Thru	Left	U-Turn	Total	Right	Thru	Left	U-Turn	Total	
7:00 AM	0	0	0	0	0	0	0	0	0	0	0	0	0	0	0	0	0	0	0	0	0
7:15 AM	0	0	0	0	0	0	0	0	0	0	0	0	0	0	0	0	0	0	0	0	0
7:30 AM	0	0	0	0	0	0	1	0	0	1	0	0	0	0	0	0	0	0	0	0	1
7:45 AM	0	0	0	0	0	0	0	0	0	0	0	0	0	0	0	0	0	0	0	0	0
<b>Total</b>	<b>0</b>	<b>0</b>	<b>0</b>	<b>0</b>	<b>0</b>	<b>0</b>	<b>1</b>	<b>0</b>	<b>0</b>	<b>1</b>	<b>0</b>	<b>0</b>	<b>0</b>	<b>0</b>	<b>0</b>	<b>0</b>	<b>0</b>	<b>0</b>	<b>0</b>	<b>0</b>	<b>1</b>
8:00 AM	0	0	0	0	0	0	0	0	0	0	0	0	0	0	0	0	0	0	0	0	0
8:15 AM	0	0	0	0	0	0	0	0	0	0	0	0	0	0	0	0	0	0	0	0	0
8:30 AM	0	0	0	0	0	0	2	0	0	2	0	0	0	0	0	0	0	0	0	0	2
8:45 AM	0	0	0	0	0	0	0	0	0	0	0	0	0	0	0	0	0	0	0	0	0
<b>Total</b>	<b>0</b>	<b>0</b>	<b>0</b>	<b>0</b>	<b>0</b>	<b>0</b>	<b>2</b>	<b>0</b>	<b>0</b>	<b>2</b>	<b>0</b>	<b>0</b>	<b>0</b>	<b>0</b>	<b>0</b>	<b>0</b>	<b>0</b>	<b>0</b>	<b>0</b>	<b>0</b>	<b>2</b>
Grand Total	0	0	0	0	0	0	3	0	0	3	0	0	0	0	0	0	0	0	0	0	3
Approach %	0.0	0.0	0.0	0.0		0.0	100.0	0.0	0.0		0.0	0.0	0.0	0.0		0.0	0.0	0.0	0.0		
Total %	0.0	0.0	0.0	0.0	0.0	0.0	100.0	0.0	0.0	100.0	0.0	0.0	0.0	0.0	0.0	0.0	0.0	0.0	0.0	0.0	0.0
Exiting Leg Total	0					0					0					3					3

Peak Hour Analysis from 07:00 AM to 09:00 AM begins at:

	Broad Rock Road					Saugatucket Road					Broad Rock Road					Saugatucket Road					Total
	from North					from East					from South					from West					
	Right	Thru	Left	U-Turn	Total	Right	Thru	Left	U-Turn	Total	Right	Thru	Left	U-Turn	Total	Right	Thru	Left	U-Turn	Total	
7:45 AM	0	0	0	0	0	0	0	0	0	0	0	0	0	0	0	0	0	0	0	0	0
7:45 AM	0	0	0	0	0	0	0	0	0	0	0	0	0	0	0	0	0	0	0	0	0
8:00 AM	0	0	0	0	0	0	0	0	0	0	0	0	0	0	0	0	0	0	0	0	0
8:15 AM	0	0	0	0	0	0	0	0	0	0	0	0	0	0	0	0	0	0	0	0	0
8:30 AM	0	0	0	0	0	0	2	0	0	2	0	0	0	0	0	0	0	0	0	0	2
Total Volume	0	0	0	0	0	0	2	0	0	2	0	0	0	0	0	0	0	0	0	0	2
% Approach Total	0.0	0.0	0.0	0.0		0.0	100.0	0.0	0.0		0.0	0.0	0.0	0.0		0.0	0.0	0.0	0.0		
PHF	0.000	0.000	0.000	0.000	0.000	0.000	0.250	0.000	0.000	0.250	0.000	0.000	0.000	0.000	0.000	0.000	0.000	0.000	0.000	0.000	0.250
Entering Leg	0	0	0	0	0	0	2	0	0	2	0	0	0	0	0	0	0	0	0	0	2
Exiting Leg	0					0					0					2					2
Total	0					2					0					2					4

PDI File #: 239193 A  
 Location: N: Broad Rock Road S: Broad Rock Road  
 Location: E: Saugatucket Road W: Saugatucket Road  
 City, State: South Kingstown, RI  
 Client: BETA/ E. Beaudry  
 Site Code: 10731  
 Count Date: Thursday, April 20, 2023  
 Start Time: 7:00 AM  
 End Time: 9:00 AM  
 Class:



**Bicycles (on Roadway and Crosswalks)**

	Broad Rock Road								Saugatucket Road								Broad Rock Road								Saugatucket Road								Total						
	from North								from East								from South								from West														
	Right	Thru	Left	U-Turn	CW-EB	CW-WB	Total		Right	Thru	Left	U-Turn	CW-SB	CW-NB	Total		Right	Thru	Left	U-Turn	CW-WB	CW-EB	Total		Right	Thru	Left	U-Turn	CW-NB	CW-SB	Total								
7:00 AM	1	0	0	0	0	0	1	0	0	0	0	0	0	0	0	0	0	0	0	0	0	0	0	0	0	0	0	0	0	0	0	0	0	0	0	0	0	0	1
7:15 AM	0	0	0	0	0	0	0	0	0	0	0	0	0	0	0	1	0	0	0	0	0	1	0	0	0	0	0	0	0	0	0	0	0	0	0	0	0	0	1
7:30 AM	0	0	0	0	0	0	0	0	0	0	0	0	0	0	0	0	0	0	0	0	0	0	0	0	0	0	0	0	0	0	0	0	0	0	0	0	0	0	0
7:45 AM	0	0	0	0	0	0	0	0	0	0	0	0	0	0	0	0	0	0	0	0	0	0	0	0	0	0	0	0	0	0	0	0	0	0	0	0	0	0	0
<b>Total</b>	<b>1</b>	<b>0</b>	<b>0</b>	<b>0</b>	<b>0</b>	<b>0</b>	<b>1</b>	<b>0</b>	<b>0</b>	<b>0</b>	<b>0</b>	<b>0</b>	<b>0</b>	<b>0</b>	<b>0</b>	<b>1</b>	<b>0</b>	<b>0</b>	<b>0</b>	<b>0</b>	<b>0</b>	<b>1</b>	<b>0</b>	<b>0</b>	<b>0</b>	<b>0</b>	<b>0</b>	<b>0</b>	<b>0</b>	<b>0</b>	<b>2</b>								
8:00 AM	0	0	0	0	0	0	0	0	0	0	0	0	0	0	0	0	0	0	0	0	0	0	0	0	0	0	0	0	0	0	0	0	0	0	0	0	0	0	0
8:15 AM	0	0	0	0	0	0	0	0	0	0	0	0	0	0	0	0	0	0	0	0	0	0	0	0	0	0	0	0	0	0	0	0	0	0	0	0	0	0	0
8:30 AM	0	0	0	0	0	0	0	0	0	0	0	0	0	0	0	0	0	0	0	0	0	0	0	0	0	0	0	0	0	0	0	0	0	0	0	0	0	0	0
8:45 AM	0	0	0	0	0	0	0	0	0	0	0	0	0	0	0	0	0	0	0	0	0	0	0	0	0	0	0	0	0	0	0	0	0	0	0	0	0	0	0
<b>Total</b>	<b>0</b>	<b>0</b>	<b>0</b>	<b>0</b>	<b>0</b>	<b>0</b>	<b>0</b>	<b>0</b>	<b>0</b>	<b>0</b>	<b>0</b>	<b>0</b>	<b>0</b>	<b>0</b>	<b>0</b>	<b>0</b>	<b>0</b>	<b>0</b>	<b>0</b>	<b>0</b>	<b>0</b>	<b>0</b>	<b>0</b>	<b>0</b>	<b>0</b>	<b>0</b>	<b>0</b>	<b>0</b>	<b>0</b>	<b>0</b>	<b>0</b>								
Grand Total	1	0	0	0	0	0	1	0	0	0	0	0	0	0	0	1	0	0	0	0	0	1	0	0	0	0	0	0	0	0	2								
Approach %	100.0	0.0	0.0	0.0	0.0	0.0		0.0	0.0	0.0	0.0	0.0	0.0		0.0	100.0	0.0	0.0	0.0	0.0		0.0	0.0	0.0	0.0	0.0	0.0	0.0											
Total %	50.0	0.0	0.0	0.0	0.0	0.0	50.0	0.0	0.0	0.0	0.0	0.0	0.0	0.0	0.0	50.0	0.0	0.0	0.0	0.0	50.0	0.0	0.0	0.0	0.0	0.0	0.0	0.0	0.0										
Exiting Leg Total	1							0							0							1							2										

Peak Hour Analysis from 07:00 AM to 09:00 AM begins at:

	Broad Rock Road								Saugatucket Road								Broad Rock Road								Saugatucket Road								Total						
	from North								from East								from South								from West														
	Right	Thru	Left	U-Turn	CW-EB	CW-WB	Total		Right	Thru	Left	U-Turn	CW-SB	CW-NB	Total		Right	Thru	Left	U-Turn	CW-WB	CW-EB	Total		Right	Thru	Left	U-Turn	CW-NB	CW-SB	Total								
7:00 AM	1	0	0	0	0	0	1	0	0	0	0	0	0	0	0	0	0	0	0	0	0	0	0	0	0	0	0	0	0	0	0	0	0	0	0	0	0	0	1
7:15 AM	0	0	0	0	0	0	0	0	0	0	0	0	0	0	0	1	0	0	0	0	0	1	0	0	0	0	0	0	0	0	0	0	0	0	0	0	0	0	1
7:30 AM	0	0	0	0	0	0	0	0	0	0	0	0	0	0	0	0	0	0	0	0	0	0	0	0	0	0	0	0	0	0	0	0	0	0	0	0	0	0	0
7:45 AM	0	0	0	0	0	0	0	0	0	0	0	0	0	0	0	0	0	0	0	0	0	0	0	0	0	0	0	0	0	0	0	0	0	0	0	0	0	0	0
Total Volume	1	0	0	0	0	0	1	0	0	0	0	0	0	0	0	1	0	0	0	0	0	1	0	0	0	0	0	0	0	0	2								
% Approach Total	100.0	0.0	0.0	0.0	0.0	0.0		0.0	0.0	0.0	0.0	0.0	0.0		0.0	100.0	0.0	0.0	0.0	0.0		0.0	0.0	0.0	0.0	0.0	0.0	0.0											
PHF	0.250	0.000	0.000	0.000	0.000	0.000	0.250	0.000	0.000	0.000	0.000	0.000	0.000	0.000	0.000	0.250	0.000	0.000	0.000	0.000	0.250	0.000	0.000	0.000	0.000	0.000	0.000	0.000	0.000	0.500									
Entering Leg	1	0	0	0	0	0	1	0	0	0	0	0	0	0	0	1	0	0	0	0	0	1	0	0	0	0	0	0	0	0	2								
Exiting Leg	1							0							0							1							2										
Total	2								0								1								1								4						



PDI File #: **239193 A**  
 Location: **N: Broad Rock Road S: Broad Rock Road**  
 Location: **E: Saugatucket Road W: Saugatucket Road**  
 City, State: **South Kingstown, RI**  
 Client: **BETA/ E. Beaudry**  
 Site Code: **10731**  
 Count Date: **Thursday, April 20, 2023**  
 Start Time: **4:00 PM**  
 End Time: **6:00 PM**  
 Class:



**Cars and Heavy Vehicles (Combined)**

	Broad Rock Road					Saugatucket Road					Broad Rock Road					Saugatucket Road					Total
	from North					from East					from South					from West					
	Right	Thru	Left	U-Turn	Total	Right	Thru	Left	U-Turn	Total	Right	Thru	Left	U-Turn	Total	Right	Thru	Left	U-Turn	Total	
4:00 PM	7	12	0	0	19	4	51	12	0	67	5	23	10	0	38	11	17	7	0	35	159
4:15 PM	4	16	2	0	22	0	49	13	0	62	3	25	13	0	41	9	15	8	0	32	157
4:30 PM	4	16	1	0	21	1	46	23	0	70	0	12	6	0	18	20	16	6	0	42	151
4:45 PM	5	21	3	0	29	3	55	26	0	84	4	14	4	0	22	24	15	5	0	44	179
<b>Total</b>	<b>20</b>	<b>65</b>	<b>6</b>	<b>0</b>	<b>91</b>	<b>8</b>	<b>201</b>	<b>74</b>	<b>0</b>	<b>283</b>	<b>12</b>	<b>74</b>	<b>33</b>	<b>0</b>	<b>119</b>	<b>64</b>	<b>63</b>	<b>26</b>	<b>0</b>	<b>153</b>	<b>646</b>
5:00 PM	9	19	4	0	32	2	48	19	0	69	4	21	11	0	36	15	10	6	0	31	168
5:15 PM	13	18	2	0	33	2	58	25	0	85	8	17	18	0	43	21	11	9	0	41	202
5:30 PM	4	12	4	0	20	3	57	19	0	79	5	14	10	0	29	21	11	6	0	38	166
5:45 PM	6	14	0	0	20	2	40	23	0	65	5	16	5	0	26	27	12	6	1	46	157
<b>Total</b>	<b>32</b>	<b>63</b>	<b>10</b>	<b>0</b>	<b>105</b>	<b>9</b>	<b>203</b>	<b>86</b>	<b>0</b>	<b>298</b>	<b>22</b>	<b>68</b>	<b>44</b>	<b>0</b>	<b>134</b>	<b>84</b>	<b>44</b>	<b>27</b>	<b>1</b>	<b>156</b>	<b>693</b>
Grand Total	52	128	16	0	196	17	404	160	0	581	34	142	77	0	253	148	107	53	1	309	1339
Approach %	26.5	65.3	8.2	0.0		2.9	69.5	27.5	0.0		13.4	56.1	30.4	0.0		47.9	34.6	17.2	0.3		
Total %	3.9	9.6	1.2	0.0	14.6	1.3	30.2	11.9	0.0	43.4	2.5	10.6	5.8	0.0	18.9	11.1	8.0	4.0	0.1	23.1	
Exiting Leg Total	212					157					436					534					1339
Cars	50	127	16	0	193	16	397	159	0	572	34	142	77	0	253	148	102	53	1	304	1322
% Cars	96.2	99.2	100.0	0.0	98.5	94.1	98.3	99.4	0.0	98.5	100.0	100.0	100.0	0.0	100.0	100.0	95.3	100.0	100.0	98.4	98.7
Exiting Leg Total	211					152					434					525					1322
Heavy Vehicles	2	1	0	0	3	1	7	1	0	9	0	0	0	0	0	0	5	0	0	5	17
% Heavy Vehicles	3.8	0.8	0.0	0.0	1.5	5.9	1.7	0.6	0.0	1.5	0.0	0.0	0.0	0.0	0.0	0.0	4.7	0.0	0.0	1.6	1.3
Exiting Leg Total	1					5					2					9					17

Peak Hour Analysis from 04:00 PM to 06:00 PM begins at:

4:45 PM	Broad Rock Road					Saugatucket Road					Broad Rock Road					Saugatucket Road					Total
	from North					from East					from South					from West					
	Right	Thru	Left	U-Turn	Total	Right	Thru	Left	U-Turn	Total	Right	Thru	Left	U-Turn	Total	Right	Thru	Left	U-Turn	Total	
4:45 PM	5	21	3	0	29	3	55	26	0	84	4	14	4	0	22	24	15	5	0	44	179
5:00 PM	9	19	4	0	32	2	48	19	0	69	4	21	11	0	36	15	10	6	0	31	168
5:15 PM	13	18	2	0	33	2	58	25	0	85	8	17	18	0	43	21	11	9	0	41	202
5:30 PM	4	12	4	0	20	3	57	19	0	79	5	14	10	0	29	21	11	6	0	38	166
Total Volume	31	70	13	0	114	10	218	89	0	317	21	66	43	0	130	81	47	26	0	154	715
% Approach Total	27.2	61.4	11.4	0.0		3.2	68.8	28.1	0.0		16.2	50.8	33.1	0.0		52.6	30.5	16.9	0.0		
PHF	0.596	0.833	0.813	0.000	0.864	0.833	0.940	0.856	0.000	0.932	0.656	0.786	0.597	0.000	0.756	0.844	0.783	0.722	0.000	0.875	0.885
Cars	30	69	13	0	112	9	217	88	0	314	21	66	43	0	130	81	45	26	0	152	708
Cars %	96.8	98.6	100.0	0.0	98.2	90.0	99.5	98.9	0.0	99.1	100.0	100.0	100.0	0.0	100.0	100.0	95.7	100.0	0.0	98.7	99.0
Heavy Vehicles	1	1	0	0	2	1	1	1	0	3	0	0	0	0	0	0	2	0	0	2	7
Heavy Vehicles %	3.2	1.4	0.0	0.0	1.8	10.0	0.5	1.1	0.0	0.9	0.0	0.0	0.0	0.0	0.0	0.0	4.3	0.0	0.0	1.3	1.0
Cars Enter Leg	30	69	13	0	112	9	217	88	0	314	21	66	43	0	130	81	45	26	0	152	708
Heavy Enter Leg	1	1	0	0	2	1	1	1	0	3	0	0	0	0	0	0	2	0	0	2	7
Total Entering Leg	31	70	13	0	114	10	218	89	0	317	21	66	43	0	130	81	47	26	0	154	715
Cars Exiting Leg	101					79					238					290					708
Heavy Exiting Leg	1					2					2					2					7
Total Exiting Leg	102					81					240					292					715

PDI File #: **239193 A**  
 Location: **N: Broad Rock Road S: Broad Rock Road**  
 Location: **E: Saugatucket Road W: Saugatucket Road**  
 City, State: **South Kingstown, RI**  
 Client: **BETA/ E. Beaudry**  
 Site Code: **10731**  
 Count Date: **Thursday, April 20, 2023**  
 Start Time: **4:00 PM**  
 End Time: **6:00 PM**  
 Class:



**Cars**

	Broad Rock Road					Saugatucket Road					Broad Rock Road					Saugatucket Road					Total
	from North					from East					from South					from West					
	Right	Thru	Left	U-Turn	Total	Right	Thru	Left	U-Turn	Total	Right	Thru	Left	U-Turn	Total	Right	Thru	Left	U-Turn	Total	
4:00 PM	6	12	0	0	18	4	46	12	0	62	5	23	10	0	38	11	17	7	0	35	153
4:15 PM	4	16	2	0	22	0	48	13	0	61	3	25	13	0	41	9	14	8	0	31	155
4:30 PM	4	16	1	0	21	1	46	23	0	70	0	12	6	0	18	20	15	6	0	41	150
4:45 PM	5	20	3	0	28	3	55	26	0	84	4	14	4	0	22	24	15	5	0	44	178
<b>Total</b>	<b>19</b>	<b>64</b>	<b>6</b>	<b>0</b>	<b>89</b>	<b>8</b>	<b>195</b>	<b>74</b>	<b>0</b>	<b>277</b>	<b>12</b>	<b>74</b>	<b>33</b>	<b>0</b>	<b>119</b>	<b>64</b>	<b>61</b>	<b>26</b>	<b>0</b>	<b>151</b>	<b>636</b>
5:00 PM	9	19	4	0	32	2	48	18	0	68	4	21	11	0	36	15	8	6	0	29	165
5:15 PM	13	18	2	0	33	1	57	25	0	83	8	17	18	0	43	21	11	9	0	41	200
5:30 PM	3	12	4	0	19	3	57	19	0	79	5	14	10	0	29	21	11	6	0	38	165
5:45 PM	6	14	0	0	20	2	40	23	0	65	5	16	5	0	26	27	11	6	1	45	156
<b>Total</b>	<b>31</b>	<b>63</b>	<b>10</b>	<b>0</b>	<b>104</b>	<b>8</b>	<b>202</b>	<b>85</b>	<b>0</b>	<b>295</b>	<b>22</b>	<b>68</b>	<b>44</b>	<b>0</b>	<b>134</b>	<b>84</b>	<b>41</b>	<b>27</b>	<b>1</b>	<b>153</b>	<b>686</b>
Grand Total	50	127	16	0	193	16	397	159	0	572	34	142	77	0	253	148	102	53	1	304	1322
Approach %	25.9	65.8	8.3	0.0		2.8	69.4	27.8	0.0		13.4	56.1	30.4	0.0		48.7	33.6	17.4	0.3		
Total %	3.8	9.6	1.2	0.0	14.6	1.2	30.0	12.0	0.0	43.3	2.6	10.7	5.8	0.0	19.1	11.2	7.7	4.0	0.1	23.0	
Exiting Leg Total	211					152					434					525					1322

Peak Hour Analysis from 04:00 PM to 06:00 PM begins at:

	Broad Rock Road					Saugatucket Road					Broad Rock Road					Saugatucket Road					Total
	from North					from East					from South					from West					
	Right	Thru	Left	U-Turn	Total	Right	Thru	Left	U-Turn	Total	Right	Thru	Left	U-Turn	Total	Right	Thru	Left	U-Turn	Total	
4:45 PM	5	20	3	0	28	3	55	26	0	84	4	14	4	0	22	24	15	5	0	44	178
5:00 PM	9	19	4	0	32	2	48	18	0	68	4	21	11	0	36	15	8	6	0	29	165
5:15 PM	13	18	2	0	33	1	57	25	0	83	8	17	18	0	43	21	11	9	0	41	200
5:30 PM	3	12	4	0	19	3	57	19	0	79	5	14	10	0	29	21	11	6	0	38	165
<b>Total Volume</b>	<b>30</b>	<b>69</b>	<b>13</b>	<b>0</b>	<b>112</b>	<b>9</b>	<b>217</b>	<b>88</b>	<b>0</b>	<b>314</b>	<b>21</b>	<b>66</b>	<b>43</b>	<b>0</b>	<b>130</b>	<b>81</b>	<b>45</b>	<b>26</b>	<b>0</b>	<b>152</b>	<b>708</b>
% Approach Total	26.8	61.6	11.6	0.0		2.9	69.1	28.0	0.0		16.2	50.8	33.1	0.0		53.3	29.6	17.1	0.0		
PHF	0.577	0.863	0.813	0.000	0.848	0.750	0.952	0.846	0.000	0.935	0.656	0.786	0.597	0.000	0.756	0.844	0.750	0.722	0.000	0.864	0.885
Entering Leg	30	69	13	0	112	9	217	88	0	314	21	66	43	0	130	81	45	26	0	152	708
Exiting Leg	101					79					238					290					708
<b>Total</b>	<b>213</b>					<b>393</b>					<b>368</b>					<b>442</b>					<b>1416</b>

PDI File #: **239193 A**  
 Location: **N: Broad Rock Road S: Broad Rock Road**  
 Location: **E: Saugatucket Road W: Saugatucket Road**  
 City, State: **South Kingstown, RI**  
 Client: **BETA/ E. Beaudry**  
 Site Code: **10731**  
 Count Date: **Thursday, April 20, 2023**  
 Start Time: **4:00 PM**  
 End Time: **6:00 PM**



**Heavy Vehicles-Combined (Buses, Single-Unit Trucks, Articulated Trucks)**

	Broad Rock Road					Saugatucket Road					Broad Rock Road					Saugatucket Road					Total
	from North					from East					from South					from West					
	Right	Thru	Left	U-Turn	Total	Right	Thru	Left	U-Turn	Total	Right	Thru	Left	U-Turn	Total	Right	Thru	Left	U-Turn	Total	
4:00 PM	1	0	0	0	1	0	5	0	0	5	0	0	0	0	0	0	0	0	0	0	6
4:15 PM	0	0	0	0	0	0	1	0	0	1	0	0	0	0	0	0	1	0	0	1	2
4:30 PM	0	0	0	0	0	0	0	0	0	0	0	0	0	0	0	0	1	0	0	1	1
4:45 PM	0	1	0	0	1	0	0	0	0	0	0	0	0	0	0	0	0	0	0	0	1
<b>Total</b>	<b>1</b>	<b>1</b>	<b>0</b>	<b>0</b>	<b>2</b>	<b>0</b>	<b>6</b>	<b>0</b>	<b>0</b>	<b>6</b>	<b>0</b>	<b>0</b>	<b>0</b>	<b>0</b>	<b>0</b>	<b>0</b>	<b>2</b>	<b>0</b>	<b>0</b>	<b>2</b>	<b>10</b>
5:00 PM	0	0	0	0	0	0	0	1	0	1	0	0	0	0	0	0	2	0	0	2	3
5:15 PM	0	0	0	0	0	1	1	0	0	2	0	0	0	0	0	0	0	0	0	0	2
5:30 PM	1	0	0	0	1	0	0	0	0	0	0	0	0	0	0	0	0	0	0	0	1
5:45 PM	0	0	0	0	0	0	0	0	0	0	0	0	0	0	0	0	1	0	0	1	1
<b>Total</b>	<b>1</b>	<b>0</b>	<b>0</b>	<b>0</b>	<b>1</b>	<b>1</b>	<b>1</b>	<b>1</b>	<b>0</b>	<b>3</b>	<b>0</b>	<b>0</b>	<b>0</b>	<b>0</b>	<b>0</b>	<b>0</b>	<b>3</b>	<b>0</b>	<b>0</b>	<b>3</b>	<b>7</b>
Grand Total	2	1	0	0	3	1	7	1	0	9	0	0	0	0	0	0	5	0	0	5	17
Approach %	66.7	33.3	0.0	0.0		11.1	77.8	11.1	0.0		0.0	0.0	0.0	0.0		0.0	100.0	0.0	0.0		
Total %	11.8	5.9	0.0	0.0	17.6	5.9	41.2	5.9	0.0	52.9	0.0	0.0	0.0	0.0	0.0	0.0	29.4	0.0	0.0	29.4	
Exiting Leg Total	1					5					2					9					17
Buses	1	0	0	0	1	1	1	1	0	3	0	0	0	0	0	0	1	0	0	1	5
% Buses	50.0	0.0	0.0	0.0	33.3	100.0	14.3	100.0	0.0	33.3	0.0	0.0	0.0	0.0	0.0	0.0	20.0	0.0	0.0	20.0	29.4
Exiting Leg Total	1					1					1					2					5
Single-Unit Trucks	1	0	0	0	1	0	4	0	0	4	0	0	0	0	0	0	4	0	0	4	9
% Single-Unit	50.0	0.0	0.0	0.0	33.3	0.0	57.1	0.0	0.0	44.4	0.0	0.0	0.0	0.0	0.0	0.0	80.0	0.0	0.0	80.0	52.9
Exiting Leg Total	0					4					0					5					9
Articulated Trucks	0	1	0	0	1	0	2	0	0	2	0	0	0	0	0	0	0	0	0	0	3
% Articulated	0.0	100.0	0.0	0.0	33.3	0.0	28.6	0.0	0.0	22.2	0.0	0.0	0.0	0.0	0.0	0.0	0.0	0.0	0.0	0.0	17.6
Exiting Leg Total	0					0					1					2					3

**Peak Hour Analysis from 04:00 PM to 06:00 PM begins at:**

	Broad Rock Road					Saugatucket Road					Broad Rock Road					Saugatucket Road					Total
	from North					from East					from South					from West					
	Right	Thru	Left	U-Turn	Total	Right	Thru	Left	U-Turn	Total	Right	Thru	Left	U-Turn	Total	Right	Thru	Left	U-Turn	Total	
4:00 PM	1	0	0	0	1	0	5	0	0	5	0	0	0	0	0	0	0	0	0	0	6
4:15 PM	0	0	0	0	0	0	1	0	0	1	0	0	0	0	0	0	1	0	0	1	2
4:30 PM	0	0	0	0	0	0	0	0	0	0	0	0	0	0	0	0	1	0	0	1	1
4:45 PM	0	1	0	0	1	0	0	0	0	0	0	0	0	0	0	0	0	0	0	0	1
<b>Total Volume</b>	<b>1</b>	<b>1</b>	<b>0</b>	<b>0</b>	<b>2</b>	<b>0</b>	<b>6</b>	<b>0</b>	<b>0</b>	<b>6</b>	<b>0</b>	<b>0</b>	<b>0</b>	<b>0</b>	<b>0</b>	<b>0</b>	<b>2</b>	<b>0</b>	<b>0</b>	<b>2</b>	<b>10</b>
<b>% Approach Total</b>	<b>50.0</b>	<b>50.0</b>	<b>0.0</b>	<b>0.0</b>		<b>0.0</b>	<b>100.0</b>	<b>0.0</b>	<b>0.0</b>		<b>0.0</b>	<b>0.0</b>	<b>0.0</b>	<b>0.0</b>		<b>0.0</b>	<b>100.0</b>	<b>0.0</b>	<b>0.0</b>		
PHF	0.250	0.250	0.000	0.000	0.500	0.000	0.300	0.000	0.000	0.300	0.000	0.000	0.000	0.000	0.000	0.000	0.500	0.000	0.000	0.500	0.417
Buses	1	0	0	0	1	0	0	0	0	0	0	0	0	0	0	0	0	0	0	0	1
Buses %	100.0	0.0	0.0	0.0	50.0	0.0	0.0	0.0	0.0	0.0	0.0	0.0	0.0	0.0	0.0	0.0	0.0	0.0	0.0	0.0	10.0
Single-Unit Trucks	0	0	0	0	0	0	4	0	0	4	0	0	0	0	0	0	2	0	0	2	6
Single-Unit %	0.0	0.0	0.0	0.0	0.0	0.0	66.7	0.0	0.0	66.7	0.0	0.0	0.0	0.0	0.0	0.0	100.0	0.0	0.0	100.0	60.0
Articulated Trucks	0	1	0	0	1	0	2	0	0	2	0	0	0	0	0	0	0	0	0	0	3
Articulated %	0.0	100.0	0.0	0.0	50.0	0.0	33.3	0.0	0.0	33.3	0.0	0.0	0.0	0.0	0.0	0.0	0.0	0.0	0.0	0.0	30.0
Buses	1	0	0	0	1	0	0	0	0	0	0	0	0	0	0	0	0	0	0	0	1
Single-Unit Trucks	0	0	0	0	0	0	4	0	0	4	0	0	0	0	0	0	2	0	0	2	6
Articulated Trucks	0	1	0	0	1	0	2	0	0	2	0	0	0	0	0	0	0	0	0	0	3
<b>Total Entering Leg</b>	<b>1</b>	<b>1</b>	<b>0</b>	<b>0</b>	<b>2</b>	<b>0</b>	<b>6</b>	<b>0</b>	<b>0</b>	<b>6</b>	<b>0</b>	<b>0</b>	<b>0</b>	<b>0</b>	<b>0</b>	<b>0</b>	<b>2</b>	<b>0</b>	<b>0</b>	<b>2</b>	<b>10</b>
Buses	0					0					0					1					1
Single-Unit Trucks	0					2					0					4					6
Articulated Trucks	0					0					1					2					3
<b>Total Exiting Leg</b>	<b>0</b>					<b>2</b>					<b>1</b>					<b>7</b>					<b>10</b>

PDI File #: **239193 A**  
 Location: **N: Broad Rock Road S: Broad Rock Road**  
 Location: **E: Saugatucket Road W: Saugatucket Road**  
 City, State: **South Kingstown, RI**  
 Client: **BETA/ E. Beaudry**  
 Site Code: **10731**  
 Count Date: **Thursday, April 20, 2023**  
 Start Time: **4:00 PM**  
 End Time: **6:00 PM**  
 Class:



**Buses**

	Broad Rock Road					Saugatucket Road					Broad Rock Road					Saugatucket Road					Total					
	from North					from East					from South					from West										
	Right	Thru	Left	U-Turn	Total	Right	Thru	Left	U-Turn	Total	Right	Thru	Left	U-Turn	Total	Right	Thru	Left	U-Turn	Total						
4:00 PM	1	0	0	0	1	0	0	0	0	0	0	0	0	0	0	0	0	0	0	0	0	0	0	0	0	1
4:15 PM	0	0	0	0	0	0	0	0	0	0	0	0	0	0	0	0	0	0	0	0	0	0	0	0	0	0
4:30 PM	0	0	0	0	0	0	0	0	0	0	0	0	0	0	0	0	0	0	0	0	0	0	0	0	0	0
4:45 PM	0	0	0	0	0	0	0	0	0	0	0	0	0	0	0	0	0	0	0	0	0	0	0	0	0	0
<b>Total</b>	<b>1</b>	<b>0</b>	<b>0</b>	<b>0</b>	<b>1</b>	<b>0</b>	<b>0</b>	<b>0</b>	<b>0</b>	<b>0</b>	<b>0</b>	<b>0</b>	<b>0</b>	<b>0</b>	<b>0</b>	<b>0</b>	<b>0</b>	<b>0</b>	<b>0</b>	<b>0</b>	<b>0</b>	<b>0</b>	<b>0</b>	<b>0</b>	<b>0</b>	<b>1</b>
5:00 PM	0	0	0	0	0	0	0	1	0	1	0	0	0	0	0	0	1	0	0	1	0	0	0	0	0	2
5:15 PM	0	0	0	0	0	1	1	0	0	2	0	0	0	0	0	0	0	0	0	0	0	0	0	0	0	2
5:30 PM	0	0	0	0	0	0	0	0	0	0	0	0	0	0	0	0	0	0	0	0	0	0	0	0	0	0
5:45 PM	0	0	0	0	0	0	0	0	0	0	0	0	0	0	0	0	0	0	0	0	0	0	0	0	0	0
<b>Total</b>	<b>0</b>	<b>0</b>	<b>0</b>	<b>0</b>	<b>0</b>	<b>1</b>	<b>1</b>	<b>1</b>	<b>0</b>	<b>3</b>	<b>0</b>	<b>0</b>	<b>0</b>	<b>0</b>	<b>0</b>	<b>0</b>	<b>1</b>	<b>0</b>	<b>0</b>	<b>1</b>	<b>0</b>	<b>0</b>	<b>0</b>	<b>0</b>	<b>1</b>	<b>4</b>
Grand Total	1	0	0	0	1	1	1	1	0	3	0	0	0	0	0	0	1	0	0	1	0	0	0	0	1	5
Approach %	100.0	0.0	0.0	0.0		33.3	33.3	33.3	0.0		0.0	0.0	0.0	0.0		0.0	100.0	0.0	0.0		0.0	0.0	0.0	0.0		
Total %	20.0	0.0	0.0	0.0	20.0	20.0	20.0	20.0	0.0	60.0	0.0	0.0	0.0	0.0	0.0	0.0	20.0	0.0	0.0	20.0	0.0	0.0	0.0	0.0	20.0	
Exiting Leg Total	1					1					1					2					5					

Peak Hour Analysis from 04:00 PM to 06:00 PM begins at:

	Broad Rock Road					Saugatucket Road					Broad Rock Road					Saugatucket Road					Total					
	from North					from East					from South					from West										
	Right	Thru	Left	U-Turn	Total	Right	Thru	Left	U-Turn	Total	Right	Thru	Left	U-Turn	Total	Right	Thru	Left	U-Turn	Total						
4:30 PM	0	0	0	0	0	0	0	0	0	0	0	0	0	0	0	0	0	0	0	0	0	0	0	0	0	0
4:45 PM	0	0	0	0	0	0	0	0	0	0	0	0	0	0	0	0	0	0	0	0	0	0	0	0	0	0
5:00 PM	0	0	0	0	0	0	0	1	0	1	0	0	0	0	0	0	1	0	0	1	0	0	0	0	0	2
5:15 PM	0	0	0	0	0	1	1	0	0	2	0	0	0	0	0	0	0	0	0	0	0	0	0	0	0	2
Total Volume	0	0	0	0	0	1	1	1	0	3	0	0	0	0	0	0	1	0	0	1	0	0	0	0	0	4
% Approach Total	0.0	0.0	0.0	0.0		33.3	33.3	33.3	0.0		0.0	0.0	0.0	0.0		0.0	100.0	0.0	0.0		0.0	0.0	0.0	0.0		
PHF	0.000	0.000	0.000	0.000	0.000	0.250	0.250	0.250	0.000	0.375	0.000	0.000	0.000	0.000	0.000	0.000	0.250	0.000	0.000	0.250	0.000	0.000	0.000	0.000	0.500	
Entering Leg	0	0	0	0	0	1	1	1	0	3	0	0	0	0	0	0	1	0	0	1	0	0	0	0	0	4
Exiting Leg	1					1					1					2					4					
Total	1					4					1					2					8					

PDI File #: **239193 A**  
 Location: **N: Broad Rock Road S: Broad Rock Road**  
 Location: **E: Saugatucket Road W: Saugatucket Road**  
 City, State: **South Kingstown, RI**  
 Client: **BETA/ E. Beaudry**  
 Site Code: **10731**  
 Count Date: **Thursday, April 20, 2023**  
 Start Time: **4:00 PM**  
 End Time: **6:00 PM**  
 Class:



**Single-Unit Trucks**

	Broad Rock Road					Saugatucket Road					Broad Rock Road					Saugatucket Road					Total
	from North					from East					from South					from West					
	Right	Thru	Left	U-Turn	Total	Right	Thru	Left	U-Turn	Total	Right	Thru	Left	U-Turn	Total	Right	Thru	Left	U-Turn	Total	
4:00 PM	0	0	0	0	0	0	3	0	0	3	0	0	0	0	0	0	0	0	0	0	3
4:15 PM	0	0	0	0	0	0	1	0	0	1	0	0	0	0	0	0	1	0	0	1	2
4:30 PM	0	0	0	0	0	0	0	0	0	0	0	0	0	0	0	0	1	0	0	1	1
4:45 PM	0	0	0	0	0	0	0	0	0	0	0	0	0	0	0	0	0	0	0	0	0
<b>Total</b>	<b>0</b>	<b>0</b>	<b>0</b>	<b>0</b>	<b>0</b>	<b>0</b>	<b>4</b>	<b>0</b>	<b>0</b>	<b>4</b>	<b>0</b>	<b>0</b>	<b>0</b>	<b>0</b>	<b>0</b>	<b>0</b>	<b>2</b>	<b>0</b>	<b>0</b>	<b>2</b>	<b>6</b>
5:00 PM	0	0	0	0	0	0	0	0	0	0	0	0	0	0	0	0	1	0	0	1	1
5:15 PM	0	0	0	0	0	0	0	0	0	0	0	0	0	0	0	0	0	0	0	0	0
5:30 PM	1	0	0	0	1	0	0	0	0	0	0	0	0	0	0	0	0	0	0	0	1
5:45 PM	0	0	0	0	0	0	0	0	0	0	0	0	0	0	0	0	1	0	0	1	1
<b>Total</b>	<b>1</b>	<b>0</b>	<b>0</b>	<b>0</b>	<b>1</b>	<b>0</b>	<b>0</b>	<b>0</b>	<b>0</b>	<b>0</b>	<b>0</b>	<b>0</b>	<b>0</b>	<b>0</b>	<b>0</b>	<b>0</b>	<b>2</b>	<b>0</b>	<b>0</b>	<b>2</b>	<b>3</b>
Grand Total	1	0	0	0	1	0	4	0	0	4	0	0	0	0	0	0	4	0	0	4	9
Approach %	100.0	0.0	0.0	0.0		0.0	100.0	0.0	0.0		0.0	0.0	0.0	0.0		0.0	100.0	0.0	0.0		
Total %	11.1	0.0	0.0	0.0	11.1	0.0	44.4	0.0	0.0	44.4	0.0	0.0	0.0	0.0	0.0	0.0	44.4	0.0	0.0	44.4	
Exiting Leg Total	0					4					0					5					9

Peak Hour Analysis from 04:00 PM to 06:00 PM begins at:

4:00 PM	Broad Rock Road					Saugatucket Road					Broad Rock Road					Saugatucket Road					Total
	from North					from East					from South					from West					
	Right	Thru	Left	U-Turn	Total	Right	Thru	Left	U-Turn	Total	Right	Thru	Left	U-Turn	Total	Right	Thru	Left	U-Turn	Total	
4:00 PM	0	0	0	0	0	0	3	0	0	3	0	0	0	0	0	0	0	0	0	0	3
4:15 PM	0	0	0	0	0	0	1	0	0	1	0	0	0	0	0	0	1	0	0	1	2
4:30 PM	0	0	0	0	0	0	0	0	0	0	0	0	0	0	0	0	1	0	0	1	1
4:45 PM	0	0	0	0	0	0	0	0	0	0	0	0	0	0	0	0	0	0	0	0	0
Total Volume	0	0	0	0	0	0	4	0	0	4	0	0	0	0	0	0	2	0	0	2	6
% Approach Total	0.0	0.0	0.0	0.0		0.0	100.0	0.0	0.0		0.0	0.0	0.0	0.0		0.0	100.0	0.0	0.0		
PHF	0.000	0.000	0.000	0.000	0.000	0.000	0.333	0.000	0.000	0.333	0.000	0.000	0.000	0.000	0.000	0.000	0.500	0.000	0.000	0.500	0.500
Entering Leg	0	0	0	0	0	0	4	0	0	4	0	0	0	0	0	0	2	0	0	2	6
Exiting Leg	0					2					0					4					6
Total	0					6					0					6					12

PDI File #: **239193 A**  
 Location: **N: Broad Rock Road S: Broad Rock Road**  
 Location: **E: Saugatucket Road W: Saugatucket Road**  
 City, State: **South Kingstown, RI**  
 Client: **BETA/ E. Beaudry**  
 Site Code: **10731**  
 Count Date: **Thursday, April 20, 2023**  
 Start Time: **4:00 PM**  
 End Time: **6:00 PM**  
 Class:



**Articulated Trucks**

	Broad Rock Road					Saugatucket Road					Broad Rock Road					Saugatucket Road					Total
	from North					from East					from South					from West					
	Right	Thru	Left	U-Turn	Total	Right	Thru	Left	U-Turn	Total	Right	Thru	Left	U-Turn	Total	Right	Thru	Left	U-Turn	Total	
4:00 PM	0	0	0	0	0	0	2	0	0	2	0	0	0	0	0	0	0	0	0	0	2
4:15 PM	0	0	0	0	0	0	0	0	0	0	0	0	0	0	0	0	0	0	0	0	0
4:30 PM	0	0	0	0	0	0	0	0	0	0	0	0	0	0	0	0	0	0	0	0	0
4:45 PM	0	1	0	0	1	0	0	0	0	0	0	0	0	0	0	0	0	0	0	0	1
<b>Total</b>	<b>0</b>	<b>1</b>	<b>0</b>	<b>0</b>	<b>1</b>	<b>0</b>	<b>2</b>	<b>0</b>	<b>0</b>	<b>2</b>	<b>0</b>	<b>0</b>	<b>0</b>	<b>0</b>	<b>0</b>	<b>0</b>	<b>0</b>	<b>0</b>	<b>0</b>	<b>0</b>	<b>3</b>
5:00 PM	0	0	0	0	0	0	0	0	0	0	0	0	0	0	0	0	0	0	0	0	0
5:15 PM	0	0	0	0	0	0	0	0	0	0	0	0	0	0	0	0	0	0	0	0	0
5:30 PM	0	0	0	0	0	0	0	0	0	0	0	0	0	0	0	0	0	0	0	0	0
5:45 PM	0	0	0	0	0	0	0	0	0	0	0	0	0	0	0	0	0	0	0	0	0
<b>Total</b>	<b>0</b>	<b>0</b>	<b>0</b>	<b>0</b>	<b>0</b>	<b>0</b>	<b>0</b>	<b>0</b>	<b>0</b>	<b>0</b>	<b>0</b>	<b>0</b>	<b>0</b>	<b>0</b>	<b>0</b>	<b>0</b>	<b>0</b>	<b>0</b>	<b>0</b>	<b>0</b>	<b>0</b>
Grand Total	0	1	0	0	1	0	2	0	0	2	0	0	0	0	0	0	0	0	0	0	3
Approach %	0.0	100.0	0.0	0.0		0.0	100.0	0.0	0.0		0.0	0.0	0.0	0.0		0.0	0.0	0.0	0.0		
Total %	0.0	33.3	0.0	0.0	33.3	0.0	66.7	0.0	0.0	66.7	0.0	0.0	0.0	0.0	0.0	0.0	0.0	0.0	0.0	0.0	
Exiting Leg Total	0					0					1					2					3

Peak Hour Analysis from 04:00 PM to 06:00 PM begins at:

	Broad Rock Road					Saugatucket Road					Broad Rock Road					Saugatucket Road					Total
	from North					from East					from South					from West					
	Right	Thru	Left	U-Turn	Total	Right	Thru	Left	U-Turn	Total	Right	Thru	Left	U-Turn	Total	Right	Thru	Left	U-Turn	Total	
4:00 PM	0	0	0	0	0	0	2	0	0	2	0	0	0	0	0	0	0	0	0	0	2
4:15 PM	0	0	0	0	0	0	0	0	0	0	0	0	0	0	0	0	0	0	0	0	0
4:30 PM	0	0	0	0	0	0	0	0	0	0	0	0	0	0	0	0	0	0	0	0	0
4:45 PM	0	1	0	0	1	0	0	0	0	0	0	0	0	0	0	0	0	0	0	0	1
<b>Total Volume</b>	<b>0</b>	<b>1</b>	<b>0</b>	<b>0</b>	<b>1</b>	<b>0</b>	<b>2</b>	<b>0</b>	<b>0</b>	<b>2</b>	<b>0</b>	<b>0</b>	<b>0</b>	<b>0</b>	<b>0</b>	<b>0</b>	<b>0</b>	<b>0</b>	<b>0</b>	<b>0</b>	<b>3</b>
% Approach Total	0.0	100.0	0.0	0.0		0.0	100.0	0.0	0.0		0.0	0.0	0.0	0.0		0.0	0.0	0.0	0.0		
PHF	0.000	0.250	0.000	0.000	0.250	0.000	0.250	0.000	0.000	0.250	0.000	0.000	0.000	0.000	0.000	0.000	0.000	0.000	0.000	0.000	0.375
Entering Leg	0	1	0	0	1	0	2	0	0	2	0	0	0	0	0	0	0	0	0	0	3
Exiting Leg	0					0					1					2					3
<b>Total</b>	<b>1</b>					<b>2</b>					<b>1</b>					<b>2</b>					<b>6</b>





---

## APPENDIX B – Traffic Crash Data

January 2017 through December 2019

Broad Rock Road at Saugatucket Road

**Crash Data Summary**

	Year			Total	Average per Year
	2017	2018	2019		
<b>Intersections</b>					
Broad Rock Road at Saugatucket Road	0	2	0	2	1
Broad Rock Road Corrido	0	0	0	0	0
<b>Corridor</b>					
Broad Rock Road at Angela Lane	0	0	0	0	0
<b>Total</b>	<b>0</b>	<b>2</b>	<b>0</b>	<b>2</b>	<b>0</b>

**Broad Rock Road at Saugatucket Road**

	2017	2018	2019	Total	Percent
<b>Collision Type</b>					
Rear End	0	0	0	0	0%
Angle	0	1	0	1	50%
Head-On	0	0	0	0	0%
Pedestrian	0	0	0	0	0%
Sideswipe, Same Direction	0	0	0	0	0%
Sideswipe, Opposite Direction	0	0	0	0	0%
Rear-to-Side	0	0	0	0	0%
Collision with Object	0	0	0	0	0%
Other	0	1	0	1	50%
Unknown	0	0	0	0	0%
<b>Crash Severity</b>					
Property	0	2	0	2	100%
Injury	0	0	0	0	0%
<b>Light Condition</b>					
Daylight	0	2	0	2	100%
Dawn	0	0	0	0	0%
Dusk	0	0	0	0	0%
Dark - Lighted	0	0	0	0	0%
Dark - Not Lighted	0	0	0	0	0%
Dark - Unknown Lighting	0	0	0	0	0%
Other	0	0	0	0	0%
Unknown	0	0	0	0	0%
<b>Road Condition</b>					
Dry	0	2	0	2	100%
Wet	0	0	0	0	0%
Snow	0	0	0	0	0%
Other	0	0	0	0	0%
Unknown	0	0	0	0	0%
<b>Hour of Day</b>					
6:00 AM - 9:00 AM	0	0	0	0	0%
9:00 AM - 3:00 PM	0	2	0	2	100%
3:00 PM - 6:00 PM	0	0	0	0	0%
6:00 PM - 6:00 AM	0	0	0	0	0%
<b>Total Crashes:</b>	<b>0</b>	<b>2</b>	<b>0</b>	<b>2</b>	

### Crash Data Summary Charts

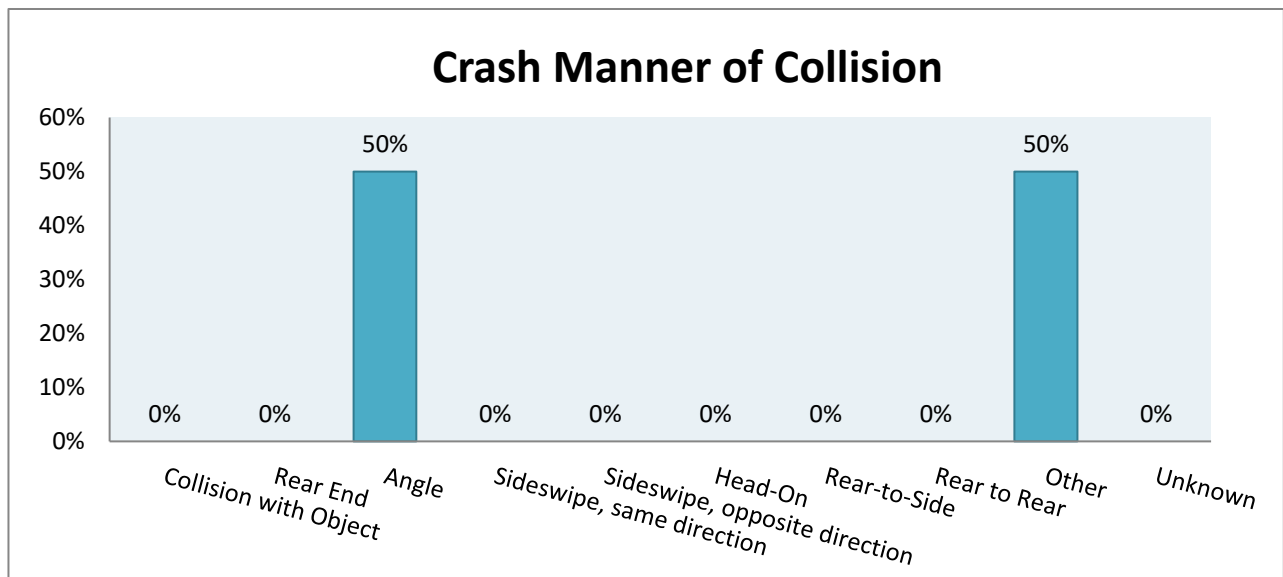
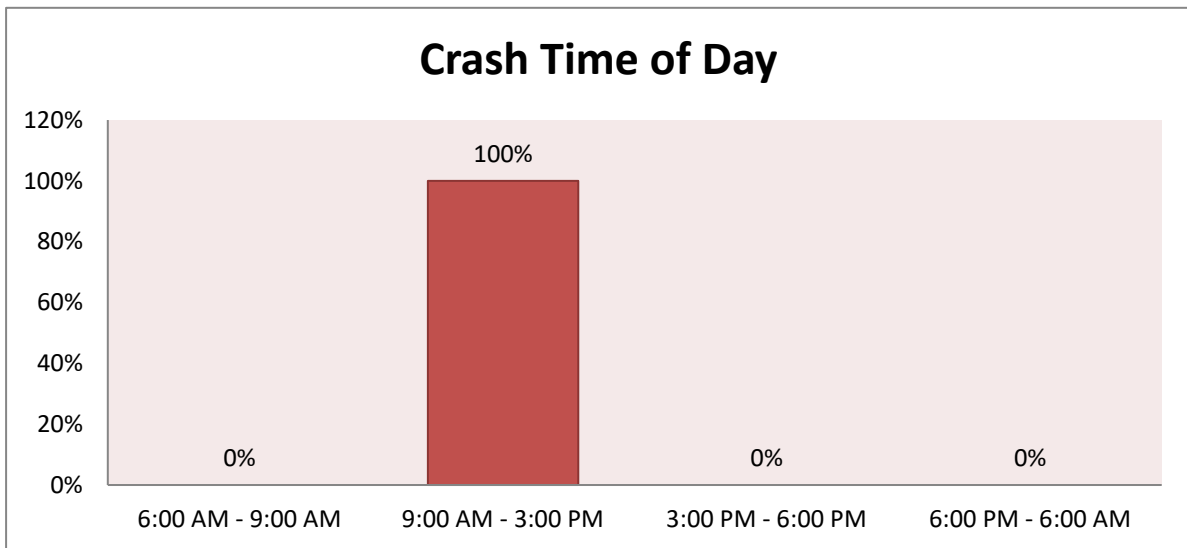
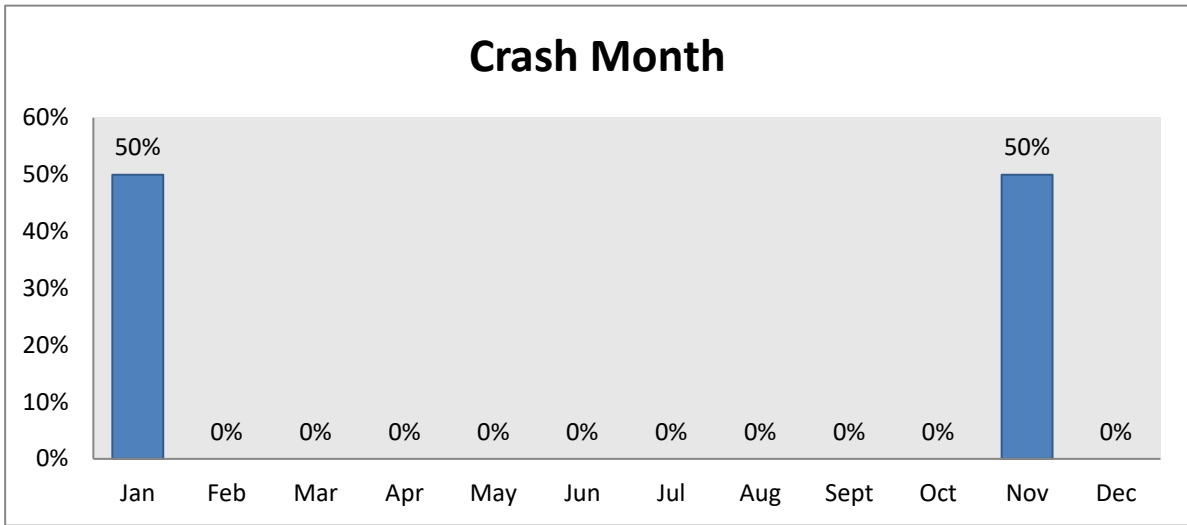

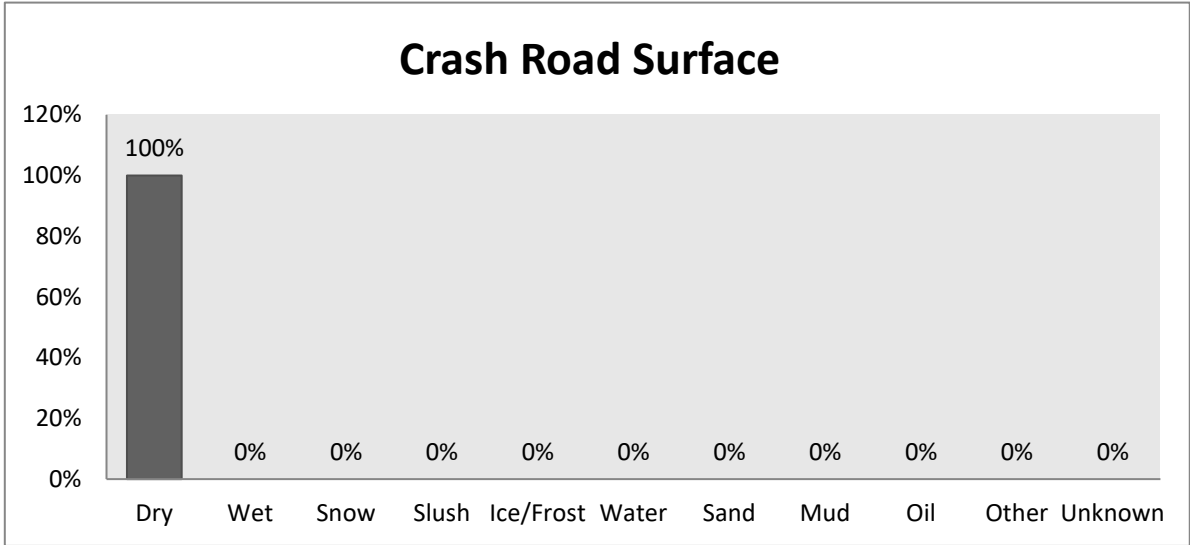
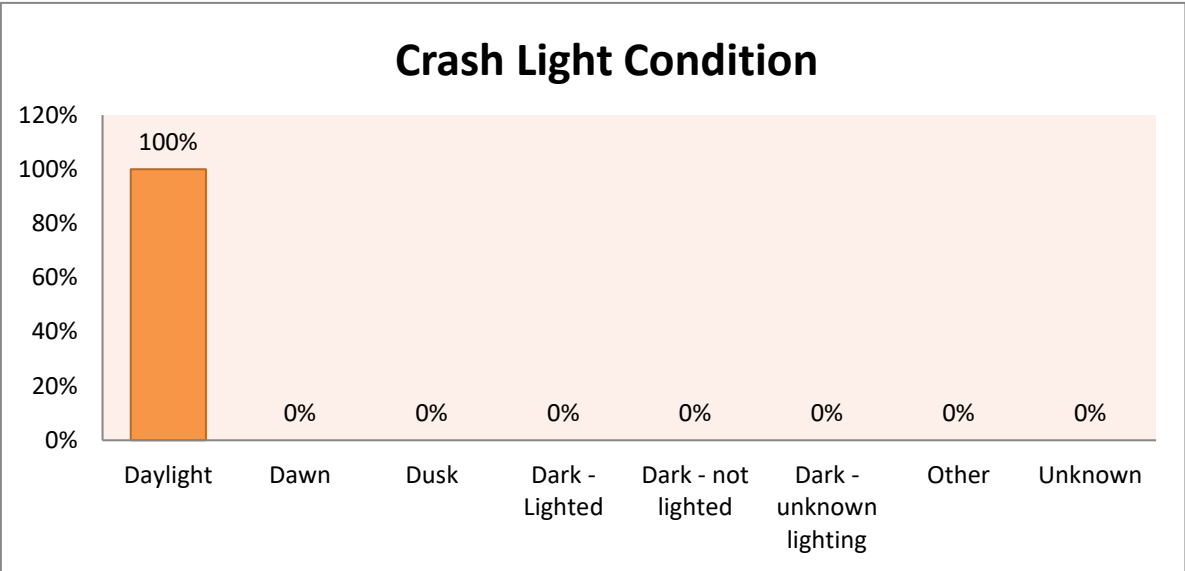

# APPENDIX C – Trip Generation

---

ITE Trip Generation Summary

Site Trip Distribution

ITE Land Use Code

ITE Land Use Code 210 – Single Family Detached Housing

C

ITE Trip Generation Summary

## Trip Generation Summary

### Summary;

	<u>Description</u>	<u>Enter</u>	<u>Exit</u>	<u>Total</u>
<u>Weekday AM Peak Hour</u>				
ITE Land Use Code 210	Residential - Single Family Detached Housing	4	9	13
<u>Weekday PM Peak Hour</u>				
ITE Land Use Code 210	Residential - Single Family Detached Housing	11	7	18

## Calculations:

ITE Land Use Code 210 Residential - Single Family Detached Housing (19 Units)

Independent Variable (X) = Dwelling Units

X = 19

AM Peak*Directional Distribution:*

26% Entering 74% Exiting

$$T = 0.70 \times (X)$$

$$\text{Enter: } 4$$

$$T = 0.70 \times 19$$

$$\text{Exit: } 9$$

$$T = 13$$

$$\text{Total: } 13$$

PM Peak*Directional Distribution:*

63% Entering 37% Exiting

$$T = 0.94 \times (X)$$

$$\text{Enter: } 11$$

$$T = 0.94 \times 19$$

$$\text{Exit: } 7$$

$$T = 18$$

$$\text{Total: } 18$$

C

---

Site Trip Distribution

**Site Trips:**

**Enter:** 4  
**Exit:** 9  
**Total:** 13

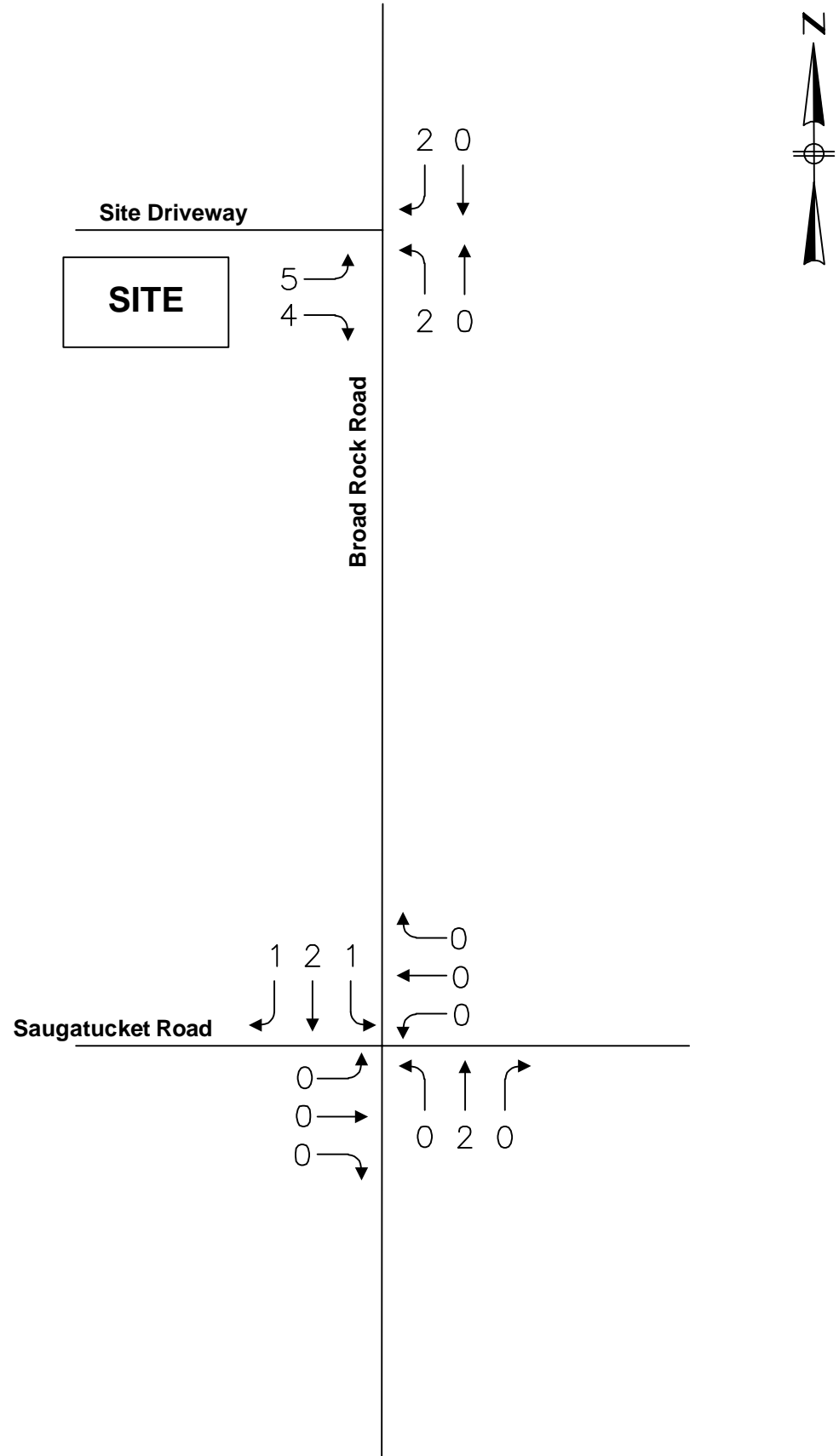

[www.BETA-Inc.com](http://www.BETA-Inc.com)

**SITE TRIP DISTRIBUTION  
WEEKDAY AM PEAK HOUR**

**PROPOSED RESIDENTIAL DEVELOPMENT  
SOUTH KINGSTOWN, RHODE ISLAND**

**Site Trips:**

Enter: 11  
 Exit: 7  
 Total: 18

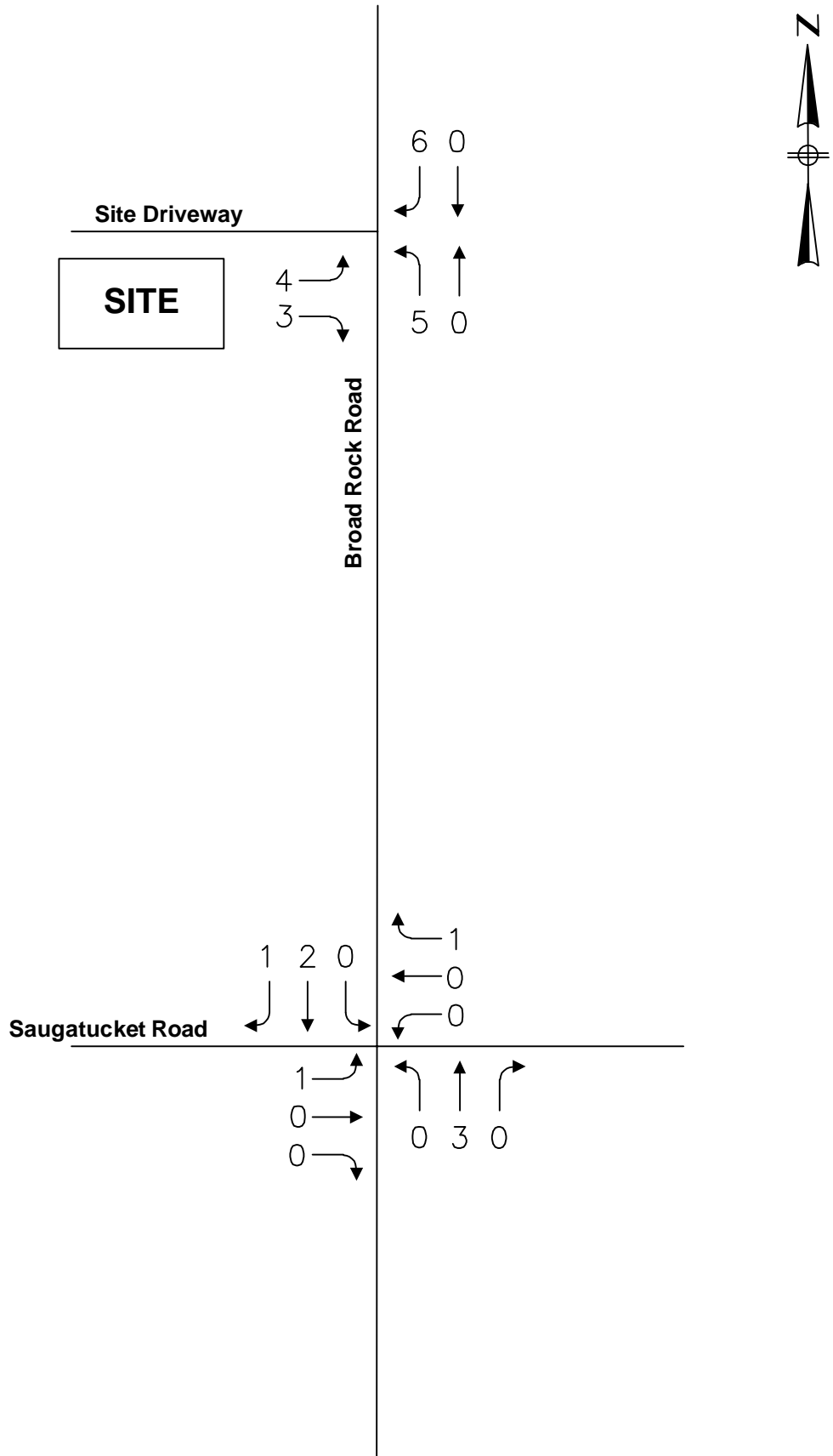

www.BETA-Inc.com

**SITE TRIP DISTRIBUTION  
 WEEKDAY PM PEAK HOUR**

**PROPOSED RESIDENTIAL DEVELOPMENT  
 SOUTH KINGSTOWN, RHODE ISLAND**

C

ITE Land Use Code

ITE Land Use Code 210 – Single Family Detached Housing

ITE Land Use Code 210 – Single Family Detached Housing

# Land Use: 210

## Single-Family Detached Housing

---

### Description

A single-family detached housing site includes any single-family detached home on an individual lot. A typical site surveyed is a suburban subdivision.

### Specialized Land Use

Data have been submitted for several single-family detached housing developments with homes that are commonly referred to as patio homes. A patio home is a detached housing unit that is located on a small lot with little (or no) front or back yard. In some subdivisions, communal maintenance of outside grounds is provided for the patio homes. The three patio home sites total 299 dwelling units with overall weighted average trip generation rates of 5.35 vehicle trips per dwelling unit for weekday, 0.26 for the AM adjacent street peak hour, and 0.47 for the PM adjacent street peak hour. These patio home rates based on a small sample of sites are lower than those for single-family detached housing (Land Use 210), lower than those for single-family attached housing (Land Use 251), and higher than those for senior adult housing – single-family (Land Use 251). Further analysis of this housing type will be conducted in a future edition of *Trip Generation Manual*.

### Additional Data

The technical appendices provide supporting information on time-of-day distributions for this land use. The appendices can be accessed through either the ITETripGen web app or the trip generation resource page on the ITE website (<https://www.ite.org/technical-resources/topics/trip-and-parking-generation/>).

For 30 of the study sites, data on the number of residents and number of household vehicles are available. The overall averages for the 30 sites are 3.6 residents per dwelling unit and 1.5 vehicles per dwelling unit.

The sites were surveyed in the 1980s, the 1990s, the 2000s, and the 2010s in Arizona, California, Connecticut, Delaware, Illinois, Indiana, Kentucky, Maryland, Massachusetts, Minnesota, Montana, New Jersey, North Carolina, Ohio, Ontario (CAN), Oregon, Pennsylvania, South Carolina, South Dakota, Tennessee, Vermont, Virginia, and West Virginia.

### Source Numbers

100, 105, 114, 126, 157, 167, 177, 197, 207, 211, 217, 267, 275, 293, 300, 319, 320, 356, 357, 367, 384, 387, 407, 435, 522, 550, 552, 579, 598, 601, 603, 614, 637, 711, 716, 720, 728, 735, 868, 869, 903, 925, 936, 1005, 1007, 1008, 1010, 1033, 1066, 1077, 1078, 1079

# Single-Family Detached Housing (210)

Vehicle Trip Ends vs: Dwelling Units  
On a: Weekday

Setting/Location: General Urban/Suburban

Number of Studies: 174

Avg. Num. of Dwelling Units: 246

Directional Distribution: 50% entering, 50% exiting

## Vehicle Trip Generation per Dwelling Unit

Average Rate	Range of Rates	Standard Deviation
9.43	4.45 - 22.61	2.13

## Data Plot and Equation

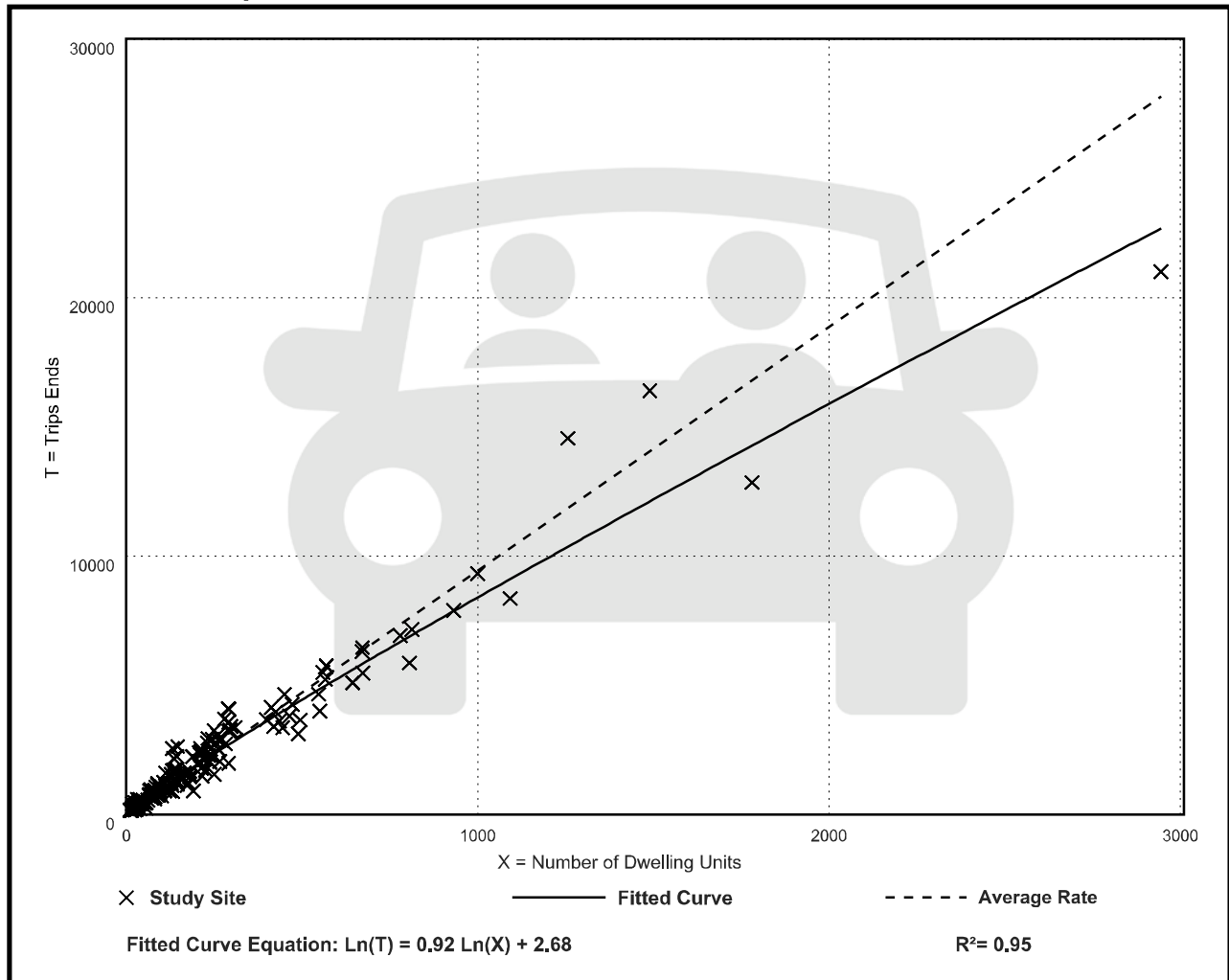

# Single-Family Detached Housing (210)

## Vehicle Trip Ends vs: Dwelling Units

On a: Weekday,

Peak Hour of Adjacent Street Traffic,

One Hour Between 7 and 9 a.m.

Setting/Location: General Urban/Suburban

Number of Studies: 192

Avg. Num. of Dwelling Units: 226

Directional Distribution: 26% entering, 74% exiting

## Vehicle Trip Generation per Dwelling Unit

Average Rate	Range of Rates	Standard Deviation
0.70	0.27 - 2.27	0.24

## Data Plot and Equation

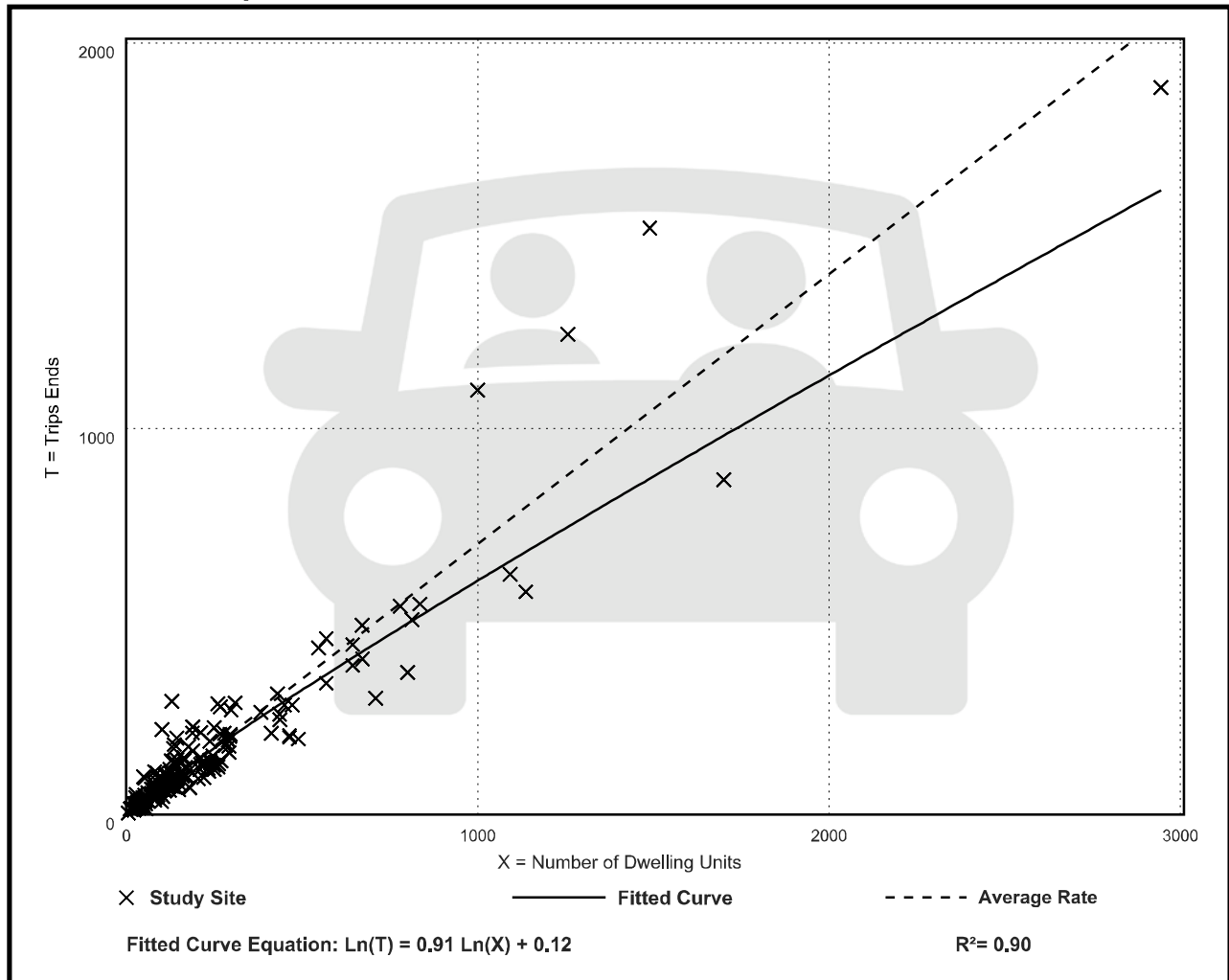

# Single-Family Detached Housing (210)

## Vehicle Trip Ends vs: Dwelling Units

On a: Weekday,

Peak Hour of Adjacent Street Traffic,

One Hour Between 4 and 6 p.m.

Setting/Location: General Urban/Suburban

Number of Studies: 208

Avg. Num. of Dwelling Units: 248

Directional Distribution: 63% entering, 37% exiting

## Vehicle Trip Generation per Dwelling Unit

Average Rate	Range of Rates	Standard Deviation
0.94	0.35 - 2.98	0.31

## Data Plot and Equation

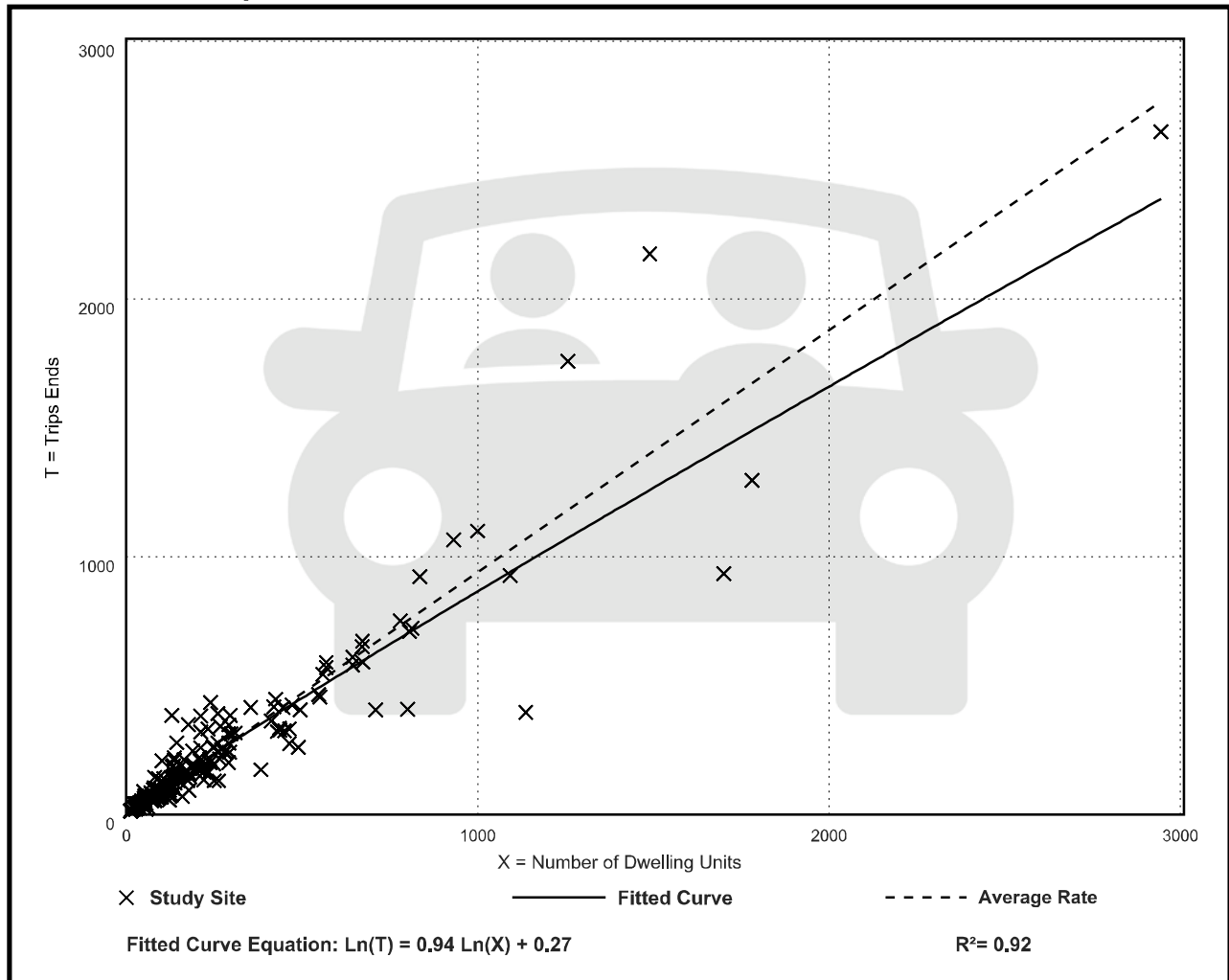

# APPENDIX D – Operational Analysis

---

## Existing Conditions

Broad Rock Road at Saugatucket Road

## Future No Build Conditions

Broad Rock Road at Saugatucket Road

## Future Build Conditions

Broad Rock Road at Saugatucket Road

Broad Rock Road at Proposed Site Driveway

D

---

Existing Weekday AM / PM Peak Hour

Broad Rock Road at Saugatucket Road

Broad Rock Road at Saugatucket Road



www.BETA-Inc.com

### Turning Movement Diagram

**Major Street:** Saugatucket Road  
**City/Town:** South Kingstown, RI  
**Reference No.:** 10731  
**Existing:** AM Peak Hour

**Minor Street:** Broad Rock Road  
**Day of Week:** Weekday  
**Peak Period:** 7:00 AM - 8:00 AM  
**Future:** n/a

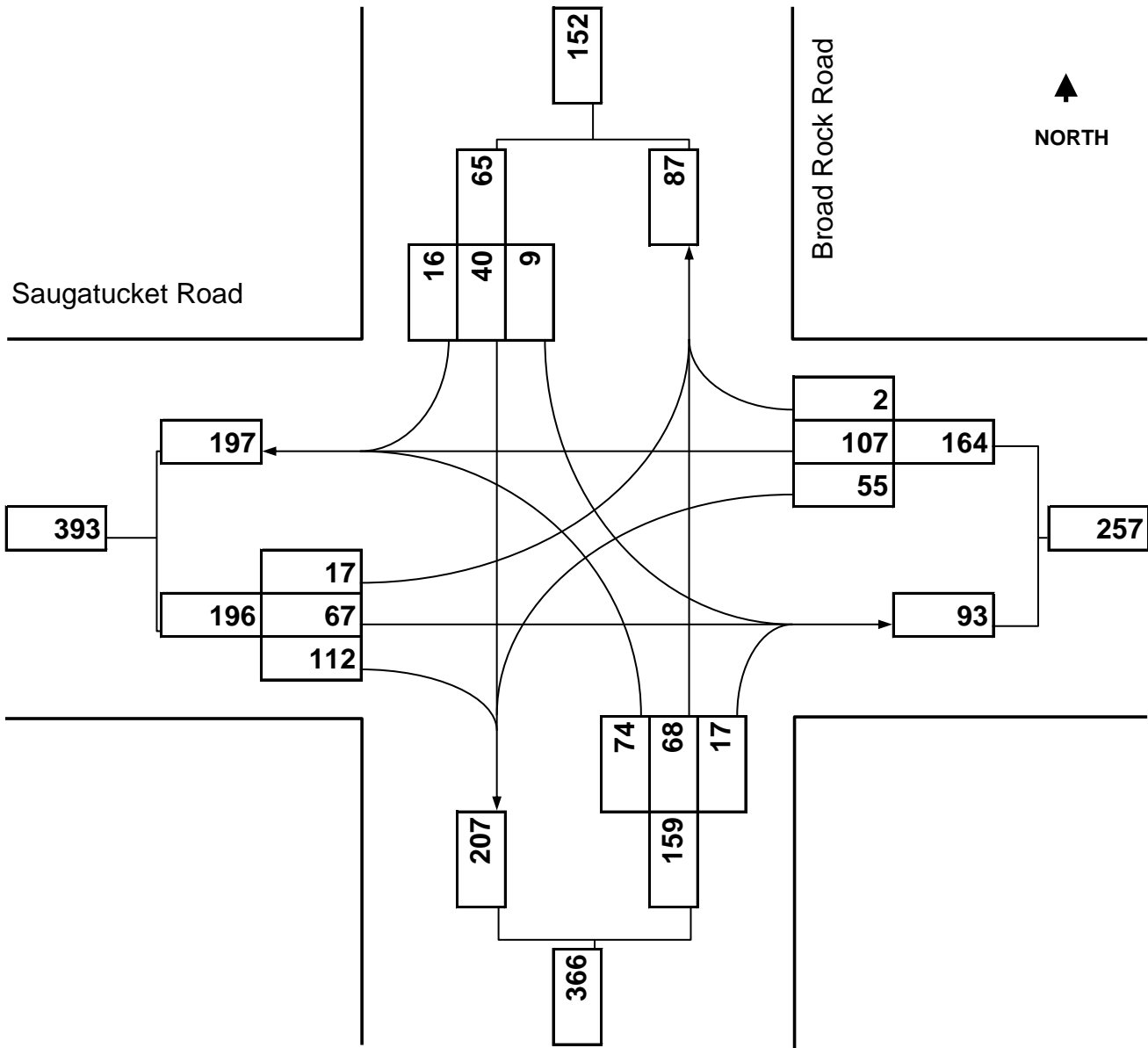

Intersection	
Intersection Delay, s/veh	10.1
Intersection LOS	B

Movement	EBL	EBT	EBR	WBL	WBT	WBR	NBL	NBT	NBR	SBL	SBT	SBR
Lane Configurations		↕			↕			↕			↕	
Traffic Vol, veh/h	17	67	112	55	107	2	74	68	17	9	40	16
Future Vol, veh/h	17	67	112	55	107	2	74	68	17	9	40	16
Peak Hour Factor	0.77	0.77	0.77	0.77	0.77	0.77	0.77	0.77	0.77	0.77	0.77	0.77
Heavy Vehicles, %	0	8	13	2	9	0	0	3	6	11	2	0
Mvmt Flow	22	87	145	71	139	3	96	88	22	12	52	21
Number of Lanes	0	1	0	0	1	0	0	1	0	0	1	0

Approach	EB	WB	NB	SB
Opposing Approach	WB	EB	SB	NB
Opposing Lanes	1	1	1	1
Conflicting Approach Left	SB	NB	EB	WB
Conflicting Lanes Left	1	1	1	1
Conflicting Approach Right	NB	SB	WB	EB
Conflicting Lanes Right	1	1	1	1
HCM Control Delay	9.9	10.3	10.4	9.3
HCM LOS	A	B	B	A

Lane	NBLn1	EBLn1	WBLn1	SBLn1
Vol Left, %	47%	9%	34%	14%
Vol Thru, %	43%	34%	65%	62%
Vol Right, %	11%	57%	1%	25%
Sign Control	Stop	Stop	Stop	Stop
Traffic Vol by Lane	159	196	164	65
LT Vol	74	17	55	9
Through Vol	68	67	107	40
RT Vol	17	112	2	16
Lane Flow Rate	206	255	213	84
Geometry Grp	1	1	1	1
Degree of Util (X)	0.295	0.326	0.299	0.128
Departure Headway (Hd)	5.143	4.604	5.05	5.479
Convergence, Y/N	Yes	Yes	Yes	Yes
Cap	690	771	703	658
Service Time	3.24	2.689	3.141	3.479
HCM Lane V/C Ratio	0.299	0.331	0.303	0.128
HCM Control Delay	10.4	9.9	10.3	9.3
HCM Lane LOS	B	A	B	A
HCM 95th-tile Q	1.2	1.4	1.3	0.4



www.BETA-Inc.com

### Turning Movement Diagram

**Major Street:** Saugatucket Road  
**City/Town:** South Kingstown, RI  
**Reference No.:** 10731  
**Existing:** PM Peak Hour

**Minor Street:** Broad Rock Road  
**Day of Week:** Weekday  
**Peak Period:** 4:30 PM - 5:30 PM  
**Future:** n/a

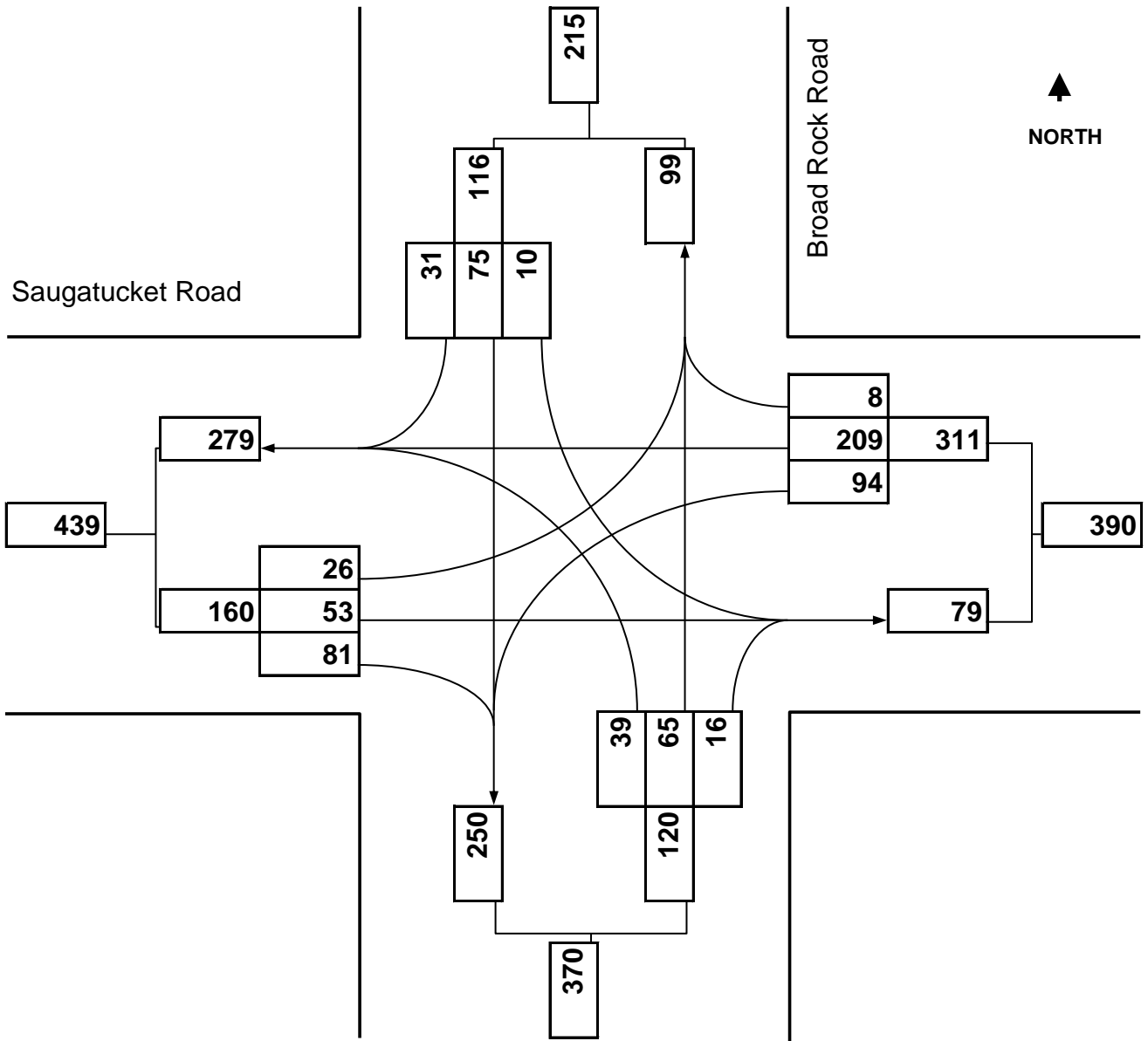

Intersection	
Intersection Delay, s/veh	10.8
Intersection LOS	B

Movement	EBL	EBT	EBR	WBL	WBT	WBR	NBL	NBT	NBR	SBL	SBT	SBR
Lane Configurations		↕			↕			↕			↕	
Traffic Vol, veh/h	26	53	81	94	209	8	39	65	16	10	75	31
Future Vol, veh/h	26	53	81	94	209	8	39	65	16	10	75	31
Peak Hour Factor	0.89	0.89	0.89	0.89	0.89	0.89	0.89	0.89	0.89	0.89	0.89	0.89
Heavy Vehicles, %	0	4	0	1	1	10	0	0	0	3	1	0
Mvmt Flow	29	60	91	106	235	9	44	73	18	11	84	35
Number of Lanes	0	1	0	0	1	0	0	1	0	0	1	0

Approach	EB	WB	NB	SB
Opposing Approach	WB	EB	SB	NB
Opposing Lanes	1	1	1	1
Conflicting Approach Left	SB	NB	EB	WB
Conflicting Lanes Left	1	1	1	1
Conflicting Approach Right	NB	SB	WB	EB
Conflicting Lanes Right	1	1	1	1
HCM Control Delay	9.4	12.3	9.8	9.7
HCM LOS	A	B	A	A

Lane	NBLn1	EBLn1	WBLn1	SBLn1
Vol Left, %	33%	16%	30%	9%
Vol Thru, %	54%	33%	67%	65%
Vol Right, %	13%	51%	3%	27%
Sign Control	Stop	Stop	Stop	Stop
Traffic Vol by Lane	120	160	311	116
LT Vol	39	26	94	10
Through Vol	65	53	209	75
RT Vol	16	81	8	31
Lane Flow Rate	135	180	349	130
Geometry Grp	1	1	1	1
Degree of Util (X)	0.204	0.243	0.472	0.194
Departure Headway (Hd)	5.436	4.871	4.969	5.369
Convergence, Y/N	Yes	Yes	Yes	Yes
Cap	662	742	730	670
Service Time	3.45	2.871	2.969	3.385
HCM Lane V/C Ratio	0.204	0.243	0.478	0.194
HCM Control Delay	9.8	9.4	12.3	9.7
HCM Lane LOS	A	A	B	A
HCM 95th-tile Q	0.8	1	2.5	0.7

D

Future 2028 No-Build Weekday AM / PM Peak Hour

Broad Rock Road at Saugatucket Road

Broad Rock Road at Saugatucket Road



www.BETA-Inc.com

### Turning Movement Diagram

**Major Street:** Saugatucket Road  
**City/Town:** South Kingstown, RI  
**Reference No.:** 10731  
**Existing:** N/A

**Minor Street:** Broad Rock Road  
**Day of Week:** Weekday  
**Peak Period:** 7:00 AM - 8:00 AM  
**Future:** 2028 No Build

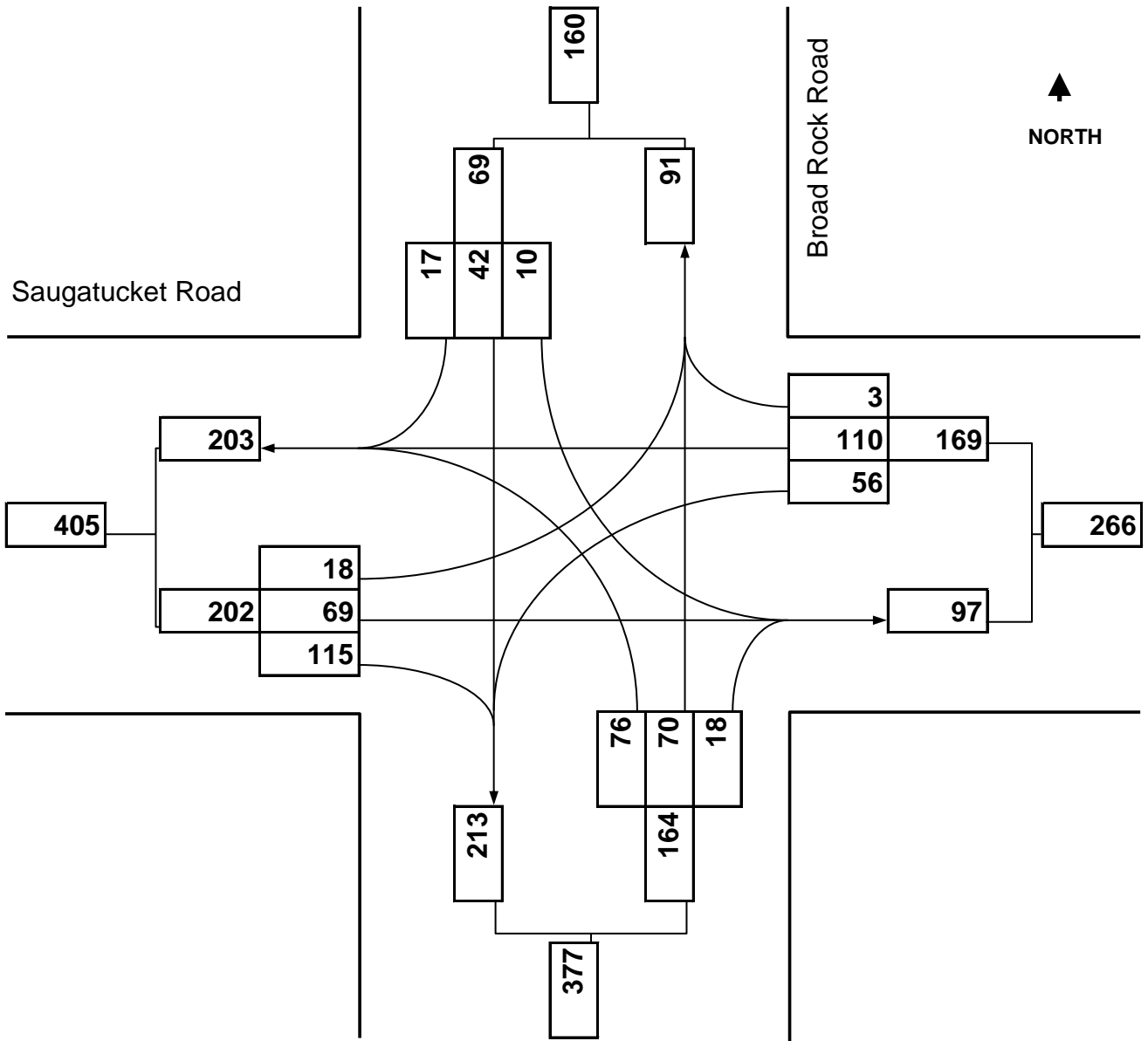

Intersection	
Intersection Delay, s/veh	10.4
Intersection LOS	B

Movement	EBL	EBT	EBR	WBL	WBT	WBR	NBL	NBT	NBR	SBL	SBT	SBR
Lane Configurations		↕			↕			↕			↕	
Traffic Vol, veh/h	18	69	115	56	110	3	76	70	18	10	42	17
Future Vol, veh/h	18	69	115	56	110	3	76	70	18	10	42	17
Peak Hour Factor	0.77	0.77	0.77	0.77	0.77	0.77	0.77	0.77	0.77	0.77	0.77	0.77
Heavy Vehicles, %	0	8	13	2	9	0	0	3	6	11	2	0
Mvmt Flow	23	90	149	73	143	4	99	91	23	13	55	22
Number of Lanes	0	1	0	0	1	0	0	1	0	0	1	0

Approach	EB	WB	NB	SB
Opposing Approach	WB	EB	SB	NB
Opposing Lanes	1	1	1	1
Conflicting Approach Left	SB	NB	EB	WB
Conflicting Lanes Left	1	1	1	1
Conflicting Approach Right	NB	SB	WB	EB
Conflicting Lanes Right	1	1	1	1
HCM Control Delay	10.3	10.6	10.7	9.5
HCM LOS	B	B	B	A

Lane	NBLn1	EBLn1	WBLn1	SBLn1
Vol Left, %	46%	9%	33%	14%
Vol Thru, %	43%	34%	65%	61%
Vol Right, %	11%	57%	2%	25%
Sign Control	Stop	Stop	Stop	Stop
Traffic Vol by Lane	164	202	169	69
LT Vol	76	18	56	10
Through Vol	70	69	110	42
RT Vol	18	115	3	17
Lane Flow Rate	213	262	219	90
Geometry Grp	1	1	1	1
Degree of Util (X)	0.313	0.347	0.318	0.138
Departure Headway (Hd)	5.293	4.76	5.208	5.544
Convergence, Y/N	Yes	Yes	Yes	Yes
Cap	679	758	694	646
Service Time	3.324	2.767	3.216	3.581
HCM Lane V/C Ratio	0.314	0.346	0.316	0.139
HCM Control Delay	10.7	10.3	10.6	9.5
HCM Lane LOS	B	B	B	A
HCM 95th-tile Q	1.3	1.6	1.4	0.5



www.BETA-Inc.com

### Turning Movement Diagram

**Major Street:** Saugatucket Road  
**City/Town:** South Kingstown, RI  
**Reference No.:** 10731  
**Existing:** N/A

**Minor Street:** Broad Rock Road  
**Day of Week:** Weekday  
**Peak Period:** 4:30 PM - 5:30 PM  
**Future:** 2028 No Build

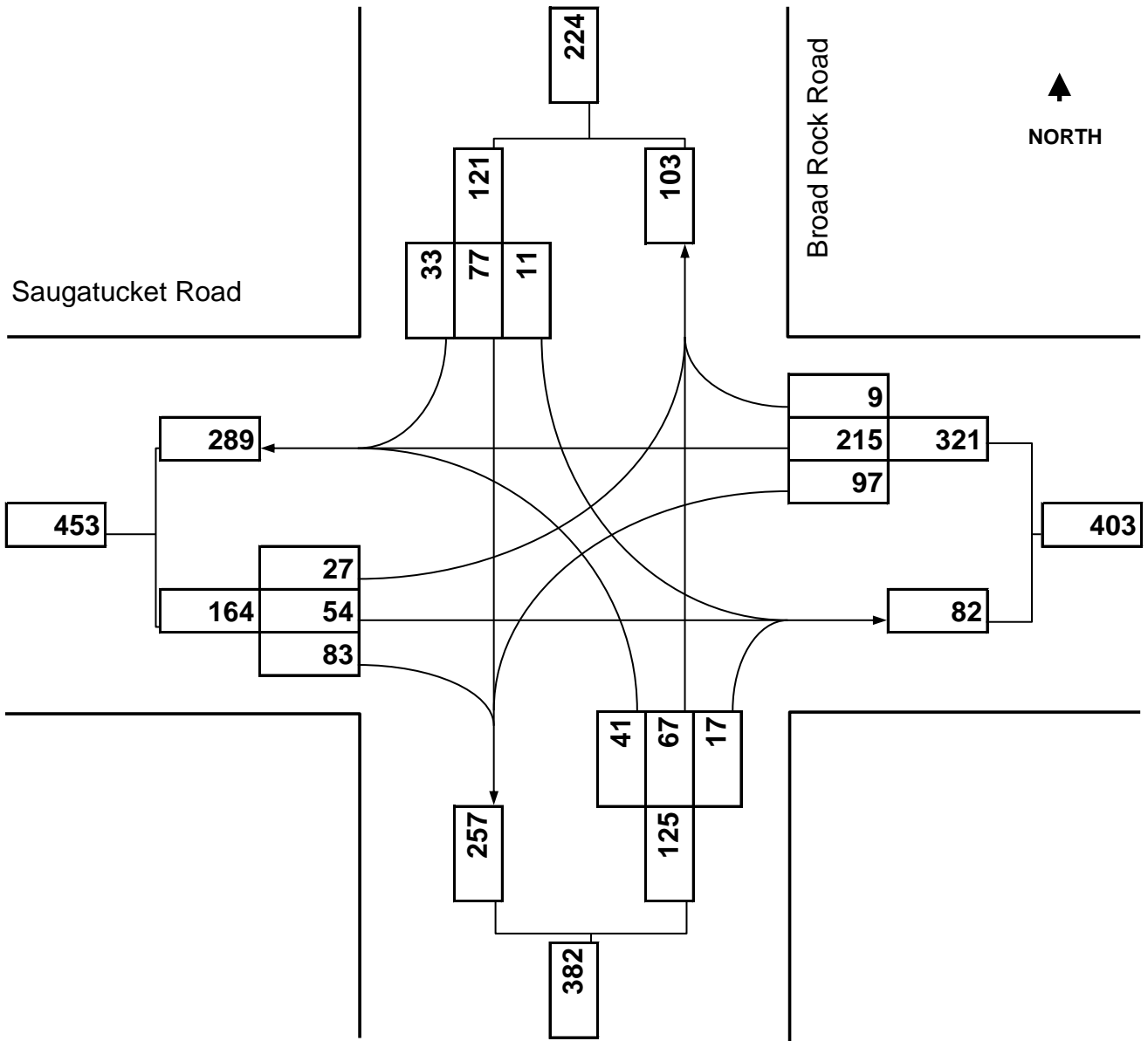

HCM 6th AWSC  
3: Broad Rock Road & Saugatucket Road

South Kingstown

Intersection	
Intersection Delay, s/veh	11.2
Intersection LOS	B

Movement	EBL	EBT	EBR	WBL	WBT	WBR	NBL	NBT	NBR	SBL	SBT	SBR
Lane Configurations		↕			↕			↕			↕	
Traffic Vol, veh/h	27	54	83	97	215	9	41	67	17	11	77	33
Future Vol, veh/h	27	54	83	97	215	9	41	67	17	11	77	33
Peak Hour Factor	0.89	0.89	0.89	0.89	0.89	0.89	0.89	0.89	0.89	0.89	0.89	0.89
Heavy Vehicles, %	0	4	0	1	1	10	0	0	0	3	1	0
Mvmt Flow	30	61	93	109	242	10	46	75	19	12	87	37
Number of Lanes	0	1	0	0	1	0	0	1	0	0	1	0

Approach	EB	WB	NB	SB
Opposing Approach	WB	EB	SB	NB
Opposing Lanes	1	1	1	1
Conflicting Approach Left	SB	NB	EB	WB
Conflicting Lanes Left	1	1	1	1
Conflicting Approach Right	NB	SB	WB	EB
Conflicting Lanes Right	1	1	1	1
HCM Control Delay	9.6	13	10	9.9
HCM LOS	A	B	A	A

Lane	NBLn1	EBLn1	WBLn1	SBLn1
Vol Left, %	33%	16%	30%	9%
Vol Thru, %	54%	33%	67%	64%
Vol Right, %	14%	51%	3%	27%
Sign Control	Stop	Stop	Stop	Stop
Traffic Vol by Lane	125	164	321	121
LT Vol	41	27	97	11
Through Vol	67	54	215	77
RT Vol	17	83	9	33
Lane Flow Rate	140	184	361	136
Geometry Grp	1	1	1	1
Degree of Util (X)	0.215	0.252	0.503	0.205
Departure Headway (Hd)	5.5	4.919	5.021	5.432
Convergence, Y/N	Yes	Yes	Yes	Yes
Cap	652	730	721	659
Service Time	3.539	2.951	3.021	3.472
HCM Lane V/C Ratio	0.215	0.252	0.501	0.206
HCM Control Delay	10	9.6	13	9.9
HCM Lane LOS	A	A	B	A
HCM 95th-tile Q	0.8	1	2.9	0.8

D

Future 2028 Build Weekday AM / PM Peak Hour

Broad Rock Road at Saugatucket Road  
Broad Rock Road at Proposed Site Driveway

Broad Rock Road at Saugatucket Road



www.BETA-Inc.com

### Turning Movement Diagram

**Major Street:** Saugatucket Road  
**City/Town:** South Kingstown, RI  
**Reference No.:** 10731  
**Existing:** N/A

**Minor Street:** Broad Rock Road  
**Day of Week:** Weekday  
**Peak Period:** 7:00 AM - 8:00 AM  
**Future:** 2028 Build

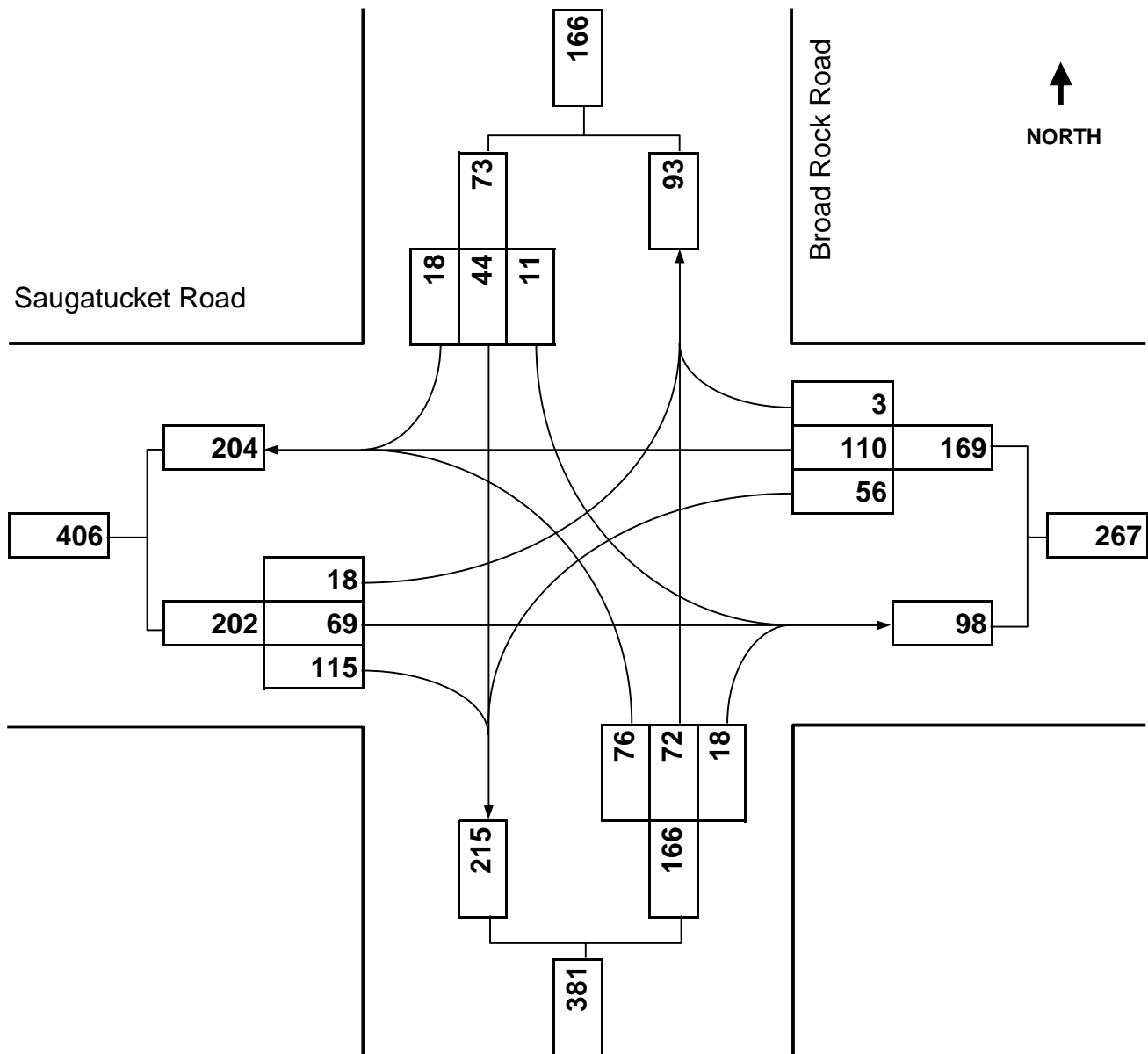

Intersection	
Intersection Delay, s/veh	10.5
Intersection LOS	B

Movement	EBL	EBT	EBR	WBL	WBT	WBR	NBL	NBT	NBR	SBL	SBT	SBR
Lane Configurations		↕			↕			↕			↕	
Traffic Vol, veh/h	18	69	115	56	110	3	76	72	18	11	44	18
Future Vol, veh/h	18	69	115	56	110	3	76	72	18	11	44	18
Peak Hour Factor	0.77	0.77	0.77	0.77	0.77	0.77	0.77	0.77	0.77	0.77	0.77	0.77
Heavy Vehicles, %	0	8	13	2	9	0	0	3	6	11	2	0
Mvmt Flow	23	90	149	73	143	4	99	94	23	14	57	23
Number of Lanes	0	1	0	0	1	0	0	1	0	0	1	0

Approach	EB	WB	NB	SB
Opposing Approach	WB	EB	SB	NB
Opposing Lanes	1	1	1	1
Conflicting Approach Left	SB	NB	EB	WB
Conflicting Lanes Left	1	1	1	1
Conflicting Approach Right	NB	SB	WB	EB
Conflicting Lanes Right	1	1	1	1
HCM Control Delay, s/veh	10.3	10.7	10.8	9.5
HCM LOS	B	B	B	A

Lane	NBLn1	EBLn1	WBLn1	SBLn1
Vol Left, %	46%	9%	33%	15%
Vol Thru, %	43%	34%	65%	60%
Vol Right, %	11%	57%	2%	25%
Sign Control	Stop	Stop	Stop	Stop
Traffic Vol by Lane	166	202	169	73
LT Vol	76	18	56	11
Through Vol	72	69	110	44
RT Vol	18	115	3	18
Lane Flow Rate	216	262	219	95
Geometry Grp	1	1	1	1
Degree of Util (X)	0.318	0.349	0.319	0.146
Departure Headway (Hd)	5.308	4.787	5.236	5.556
Convergence, Y/N	Yes	Yes	Yes	Yes
Cap	677	756	689	645
Service Time	3.339	2.794	3.245	3.594
HCM Lane V/C Ratio	0.319	0.347	0.318	0.147
HCM Control Delay, s/veh	10.8	10.3	10.7	9.5
HCM Lane LOS	B	B	B	A
HCM 95th-tile Q	1.4	1.6	1.4	0.5



www.BETA-Inc.com

### Turning Movement Diagram

**Major Street:** Saugatucket Road  
**City/Town:** South Kingstown, RI  
**Reference No.:** 10731  
**Existing:** N/A

**Minor Street:** Broad Rock Road  
**Day of Week:** Weekday  
**Peak Period:** 4:30 PM - 5:30 PM  
**Future:** 2028 Build

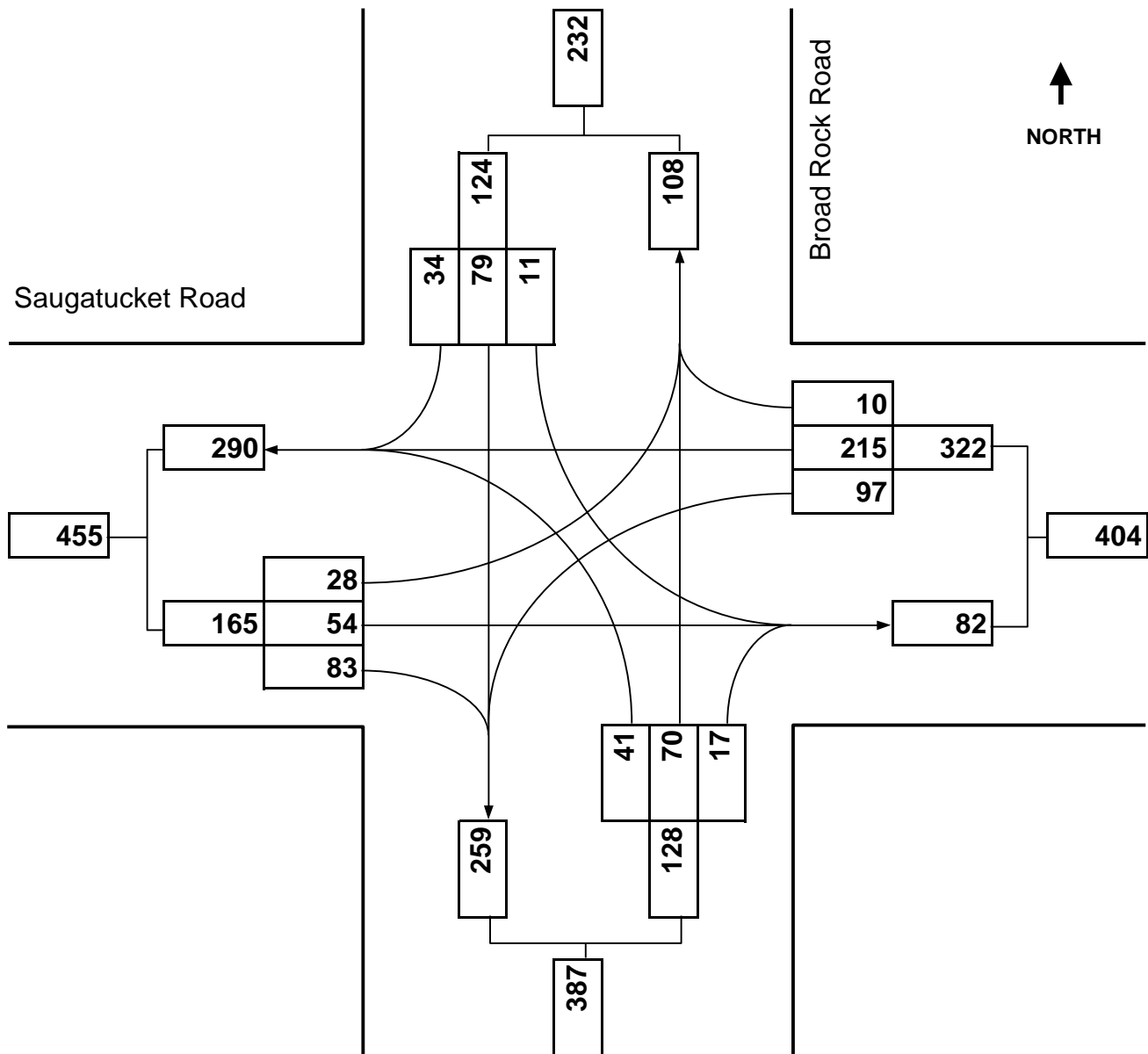

Intersection	
Intersection Delay, s/veh	11.3
Intersection LOS	B

Movement	EBL	EBT	EBR	WBL	WBT	WBR	NBL	NBT	NBR	SBL	SBT	SBR
Lane Configurations		↕			↕			↕			↕	
Traffic Vol, veh/h	28	54	83	97	215	10	41	70	17	11	79	34
Future Vol, veh/h	28	54	83	97	215	10	41	70	17	11	79	34
Peak Hour Factor	0.89	0.89	0.89	0.89	0.89	0.89	0.89	0.89	0.89	0.89	0.89	0.89
Heavy Vehicles, %	0	4	0	1	1	10	0	0	0	3	1	0
Mvmt Flow	31	61	93	109	242	11	46	79	19	12	89	38
Number of Lanes	0	1	0	0	1	0	0	1	0	0	1	0

Approach	EB	WB	NB	SB
Opposing Approach	WB	EB	SB	NB
Opposing Lanes	1	1	1	1
Conflicting Approach Left	SB	NB	EB	WB
Conflicting Lanes Left	1	1	1	1
Conflicting Approach Right	NB	SB	WB	EB
Conflicting Lanes Right	1	1	1	1
HCM Control Delay, s/veh	9.7	13.1	10.1	10
HCM LOS	A	B	B	A

Lane	NBLn1	EBLn1	WBLn1	SBLn1
Vol Left, %	32%	17%	30%	9%
Vol Thru, %	55%	33%	67%	64%
Vol Right, %	13%	50%	3%	27%
Sign Control	Stop	Stop	Stop	Stop
Traffic Vol by Lane	128	165	322	124
LT Vol	41	28	97	11
Through Vol	70	54	215	79
RT Vol	17	83	10	34
Lane Flow Rate	144	185	362	139
Geometry Grp	1	1	1	1
Degree of Util (X)	0.221	0.255	0.507	0.211
Departure Headway (Hd)	5.52	4.95	5.046	5.451
Convergence, Y/N	Yes	Yes	Yes	Yes
Cap	650	725	720	658
Service Time	3.56	2.984	3.046	3.492
HCM Lane V/C Ratio	0.222	0.255	0.503	0.211
HCM Control Delay, s/veh	10.1	9.7	13.1	10
HCM Lane LOS	B	A	B	A
HCM 95th-tile Q	0.8	1	2.9	0.8

Broad Rock Road at Proposed Site Driveway



www.BETA-Inc.com

### Turning Movement Diagram

**Major Street:** Broad Rock Road  
**City/Town:** South Kingstown, RI  
**Reference No.:** 10731  
**Existing:** N/A

**Minor Street:** Site Access Road  
**Day of Week:** Weekday  
**Peak Period:** 7:00 AM - 8:00 AM  
**Future:** 2028 Build

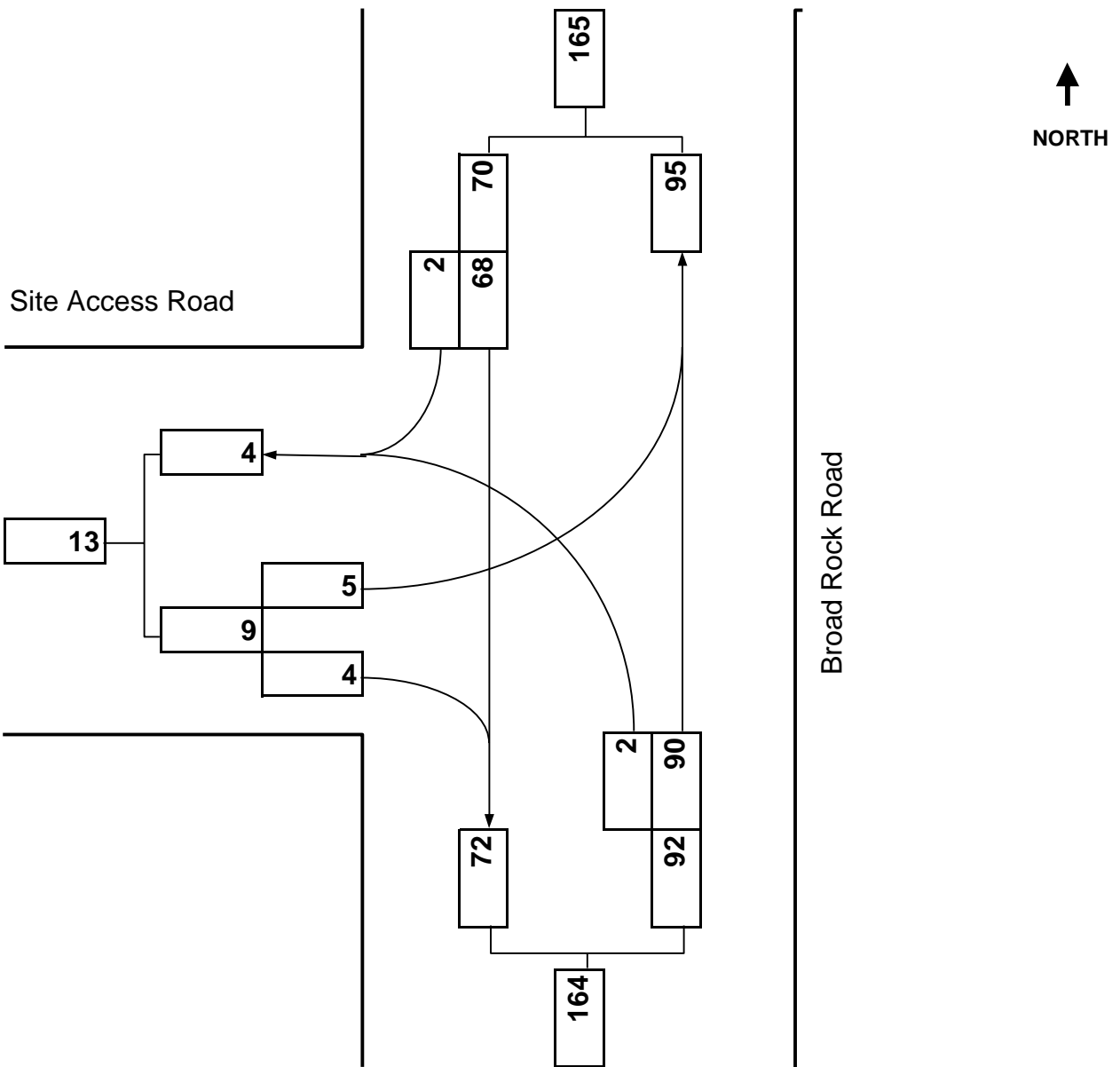

Intersection						
Int Delay, s/veh	0.6					
Movement	EBL	EBR	NBL	NBT	SBT	SBR
Lane Configurations	W			4	4	
Traffic Vol, veh/h	5	4	2	90	68	2
Future Vol, veh/h	5	4	2	90	68	2
Conflicting Peds, #/hr	0	0	0	0	0	0
Sign Control	Stop	Stop	Free	Free	Free	Free
RT Channelized	-	None	-	None	-	None
Storage Length	0	-	-	-	-	-
Veh in Median Storage, #	0	-	-	0	0	-
Grade, %	0	-	-	0	0	-
Peak Hour Factor	92	92	92	92	92	92
Heavy Vehicles, %	2	2	2	2	2	2
Mvmt Flow	5	4	2	98	74	2

Major/Minor	Minor2	Major1		Major2	
Conflicting Flow All	177	75	76	0	0
Stage 1	75	-	-	-	-
Stage 2	102	-	-	-	-
Critical Hdwy	6.42	6.22	4.12	-	-
Critical Hdwy Stg 1	5.42	-	-	-	-
Critical Hdwy Stg 2	5.42	-	-	-	-
Follow-up Hdwy	3.518	3.318	2.218	-	-
Pot Cap-1 Maneuver	813	986	1523	-	-
Stage 1	948	-	-	-	-
Stage 2	922	-	-	-	-
Platoon blocked, %				-	-
Mov Cap-1 Maneuver	812	986	1523	-	-
Mov Cap-2 Maneuver	812	-	-	-	-
Stage 1	947	-	-	-	-
Stage 2	922	-	-	-	-

Approach	EB	NB	SB
HCM Control Delay, s/v	9.1	0.2	0
HCM LOS	A		

Minor Lane/Major Mvmt	NBL	NBT	EBLn1	SBT	SBR
Capacity (veh/h)	1523	-	881	-	-
HCM Lane V/C Ratio	0.001	-	0.011	-	-
HCM Control Delay (s/veh)	7.4	0	9.1	-	-
HCM Lane LOS	A	A	A	-	-
HCM 95th %tile Q (veh)	0	-	0	-	-



www.BETA-Inc.com

### Turning Movement Diagram

**Major Street:** Broad Rock Road  
**City/Town:** South Kingstown, RI  
**Reference No.:** 10731  
**Existing:** N/A

**Minor Street:** Site Access Road  
**Day of Week:** Weekday  
**Peak Period:** 4:30 PM - 5:30 PM  
**Future:** 2028 Build

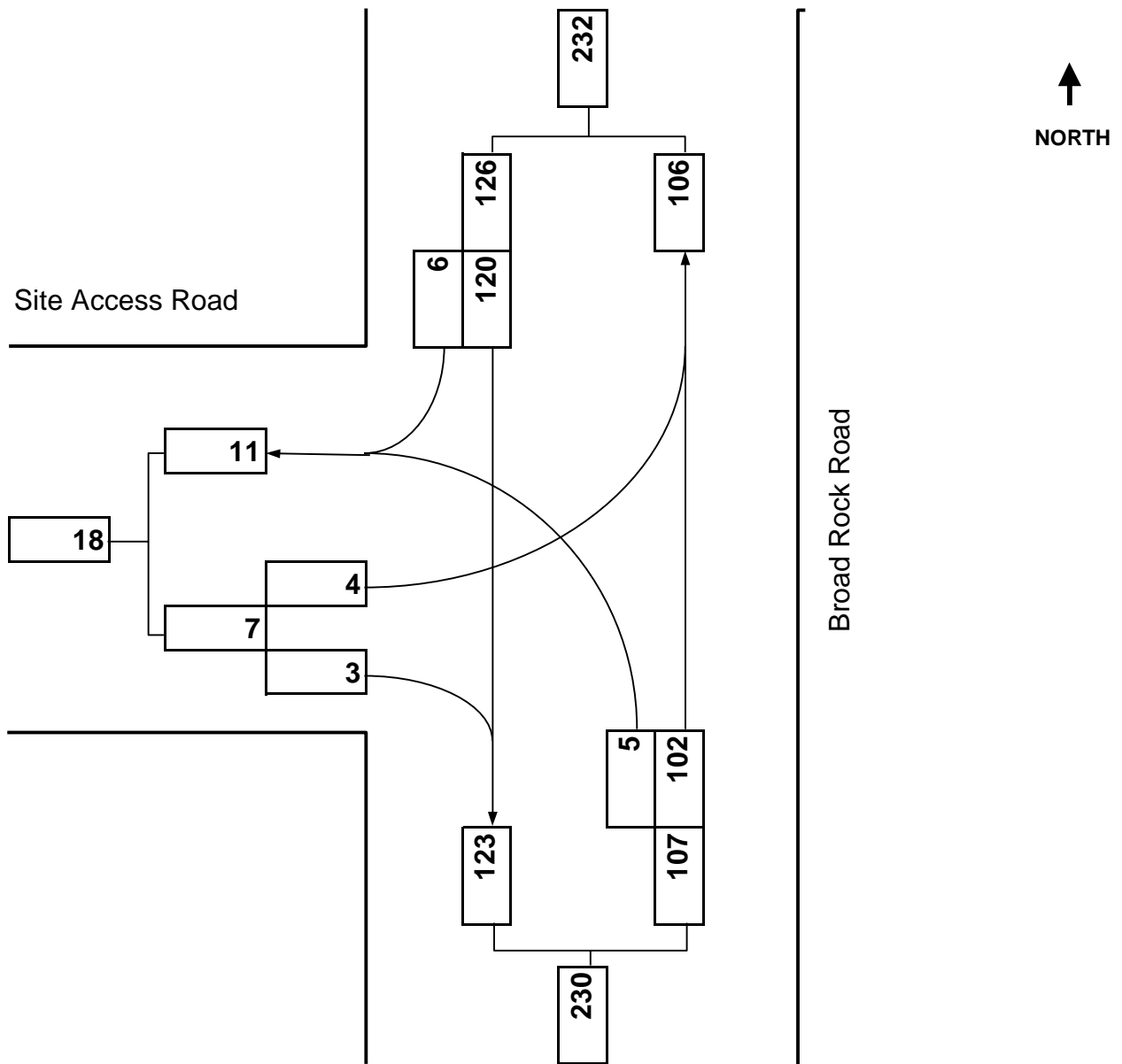

Intersection						
Int Delay, s/veh	0.5					
Movement	EBL	EBR	NBL	NBT	SBT	SBR
Lane Configurations	W			W	W	
Traffic Vol, veh/h	4	3	5	102	120	6
Future Vol, veh/h	4	3	5	102	120	6
Conflicting Peds, #/hr	0	0	0	0	0	0
Sign Control	Stop	Stop	Free	Free	Free	Free
RT Channelized	-	None	-	None	-	None
Storage Length	0	-	-	-	-	-
Veh in Median Storage, #	0	-	-	0	0	-
Grade, %	0	-	-	0	0	-
Peak Hour Factor	92	92	92	92	92	92
Heavy Vehicles, %	2	2	2	2	2	2
Mvmt Flow	4	3	5	111	130	7

Major/Minor	Minor2	Major1	Major2			
Conflicting Flow All	255	134	137	0	-	0
Stage 1	134	-	-	-	-	-
Stage 2	121	-	-	-	-	-
Critical Hdwy	6.42	6.22	4.12	-	-	-
Critical Hdwy Stg 1	5.42	-	-	-	-	-
Critical Hdwy Stg 2	5.42	-	-	-	-	-
Follow-up Hdwy	3.518	3.318	2.218	-	-	-
Pot Cap-1 Maneuver	734	915	1447	-	-	-
Stage 1	892	-	-	-	-	-
Stage 2	904	-	-	-	-	-
Platoon blocked, %				-	-	-
Mov Cap-1 Maneuver	731	915	1447	-	-	-
Mov Cap-2 Maneuver	731	-	-	-	-	-
Stage 1	888	-	-	-	-	-
Stage 2	904	-	-	-	-	-

Approach	EB	NB	SB
HCM Control Delay, s/v	9.5	0.4	0
HCM LOS	A		

Minor Lane/Major Mvmt	NBL	NBT	EBLn1	SBT	SBR
Capacity (veh/h)	1447	-	800	-	-
HCM Lane V/C Ratio	0.004	-	0.01	-	-
HCM Control Delay (s/veh)	7.5	0	9.5	-	-
HCM Lane LOS	A	A	A	-	-
HCM 95th %tile Q (veh)	0	-	0	-	-