

FLEXIBLE DESIGN RESIDENTIAL PROJECT VILLAGE AT BROAD ROCK

for
PLAT 33, LOT 24
 ZONED R-40
 in
 SOUTH KINGSTOWN, RHODE ISLAND

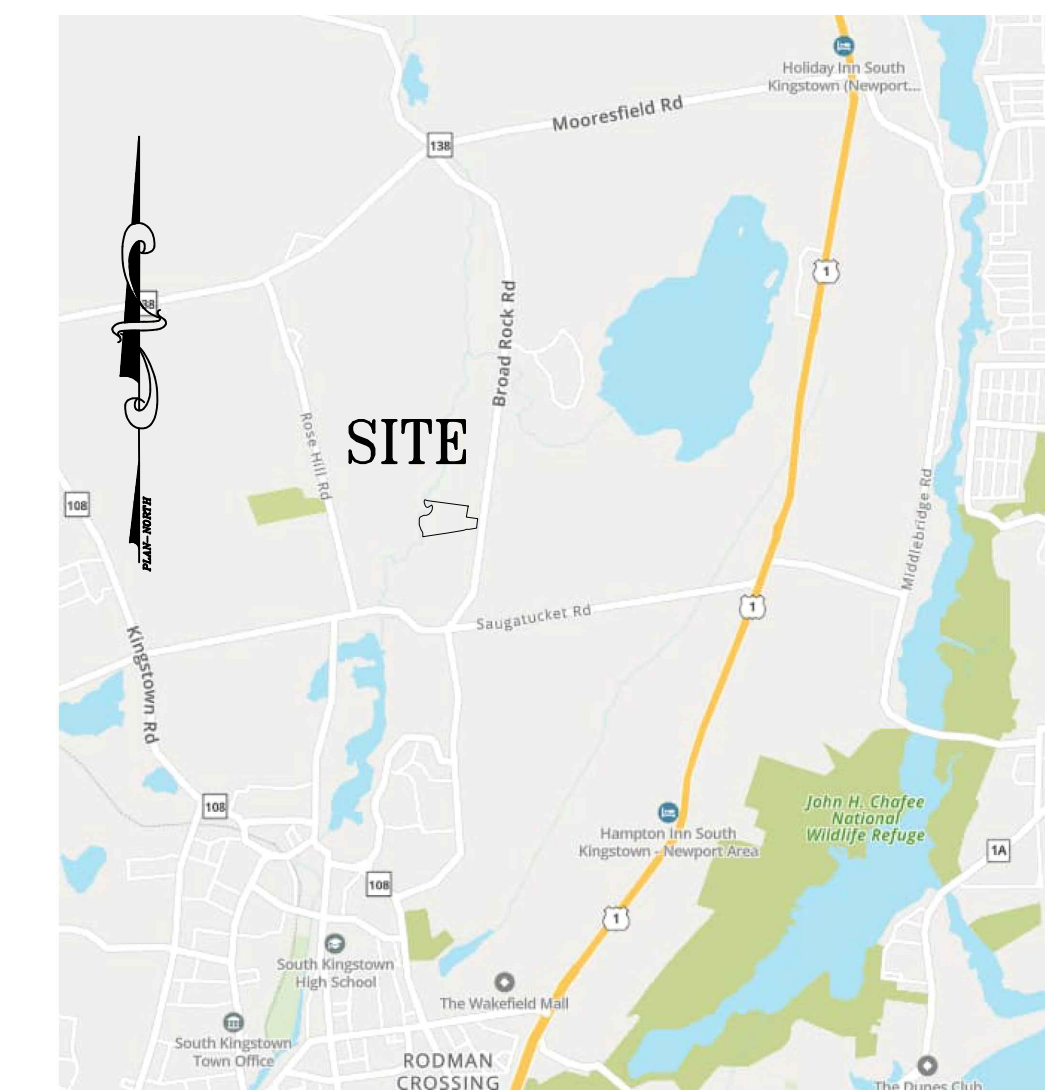

LOCUS MAP
NOT TO SCALE

LIST OF DRAWINGS

1. TITLE SHEET
2. NOTES AND LEGEND PLAN
3. EXISTING CONDITIONS PLAN
4. PROPOSED LAYOUT PLAN
5. PROPOSED GRADING AND DRAINAGE PLAN
6. PROPOSED UTILITY PLAN
7. PROPOSED OWTS LOCATION PLAN
8. PROPOSED ROADWAY PROFILE PLAN
9. PROPOSED STONEWALL PLAN
10. SOIL EROSION AND SEDIMENT CONTROL PLAN
11. SOIL EROSION AND SEDIMENT CONTROL DETAILS
12. CONSTRUCTION DETAILS PLAN-1
13. CONSTRUCTION DETAILS PLAN-2
14. CONSTRUCTION DETAILS PLAN-3
15. CONSTRUCTION DETAILS PLAN-4
16. CONSTRUCTION DETAILS PLAN-5
17. PROPOSED RECORD PLAN
18. SURVEY PLAN, SHEET 1 OF 1
19. LANDSCAPE PLANS, 6 SHEETS

PROJECT DATA

ZONING TABLE:

ZONE:	R-40		
A.P./LOT	33/24		
LOT AREA	16.50 AC.		
R-40 ZONING REGULATIONS:		R-10 ZONING REGULATIONS:	
AREA	40,000 SQ. FT.	AREA	10,000 SQ. FT.
FRONTAGE	150 FT.	FRONTAGE	80 FT.
WIDTH	150 FT.	WIDTH	80 FT.
BLDG. COVERAGE	20%	BLDG. COVERAGE	25%
HEIGHT (PRINC.)	35 FT.	HEIGHT (PRINC.)	35 FT.
HEIGHT (ACCESS.)	20 FT.	HEIGHT (ACCESS.)	15 FT.
FRONT YARD	40 FT.	FRONT YARD	25 FT.
CORNER SIDE	30 FT.	CORNER SIDE	20 FT.
SIDE YARD	20 FT.	SIDE YARD	10 FT.
REAR YARD	40 FT.	REAR YARD	30 FT.
ACCESS. BLDG. SIDE	15 FT.	ACCESS. BLDG. SIDE	6 FT.
ACCESS. BLDG. REAR	10 FT.	ACCESS. BLDG. REAR	6 FT.
OWTS TO WETLAND	150 FT.	OWTS TO WETLAND	150 FT.

DENSITY CALCULATIONS:

YIELD PLAN= 13 LOTS

INCLUSIONARY INCENTIVE BONUS:

IN ACCORDANCE WITH RI GENERAL LAW §45-24-46.1.C, FOR EACH INCLUSIONARY LOT PROVIDED, 2 MARKET RATE LOTS SHALL BE PROVIDED AS A DENSITY BONUS.

3 AFFORDABLE LOTS ARE PROVIDED; THEREFORE, 6 ADDITIONAL MARKET RATE LOTS ARE PROVIDED.

TOTAL LOTS = 13 + 6 = 19 LOTS

LOTS 6, 11 AND 18 SHALL BE AFFORDABLE HOUSING LOTS

DATE OF PLAN SET: FEBRUARY 28, 2024

REVISIONS

	DATE	DRWN	CHKD
PLANNING DEPT. COMMENTS	4/2/2024	TB	TB
TRC COMMENTS	4/18/2024	TB	TB
SITE DESIGN	9/06/2024	SMA	TB
WATER SYSTEM DESIGN	9/30/2024	SMA	TB
RIDEM STORMWATER COMMENTS	10/21/2024	SMA	TB
FIRE MARSHALL COMMENTS	11/24/2024	SMA	TB

PROJECT NO. 23011.00

OWNER:
 SHELEEN M CLARKE REV LIV TRUST AGMT
 96 DUCK COVE ROAD
 NORTH KINGSTOWN, RI 02852

APPLICANT:
 NEW ENGLAND PROPERTIES, LLC
 257 WICKFORD CT.
 NORTH KINGSTOWN, RI 02852

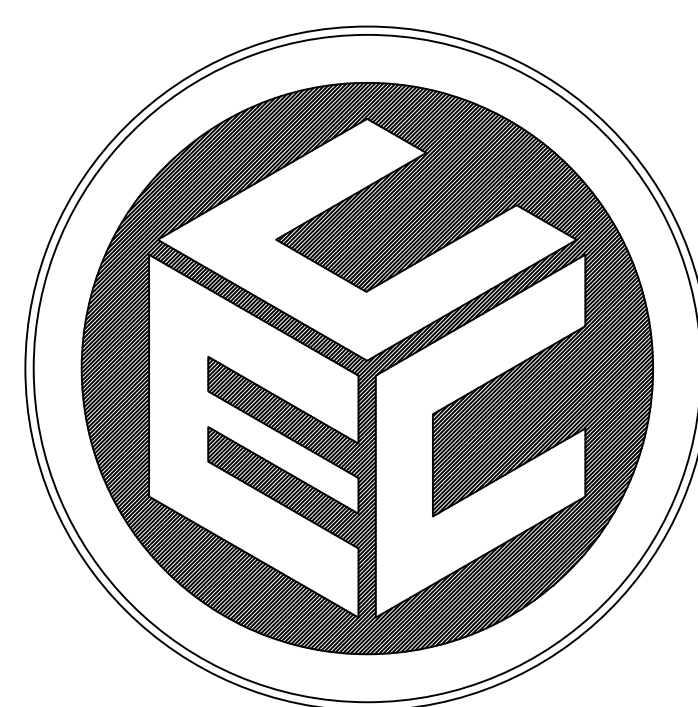

COMMONWEALTH
 ENGINEERS & CONSULTANTS, INC.

400 SMITH STREET
 PROVIDENCE, RHODE ISLAND 02908
 401-273-6604

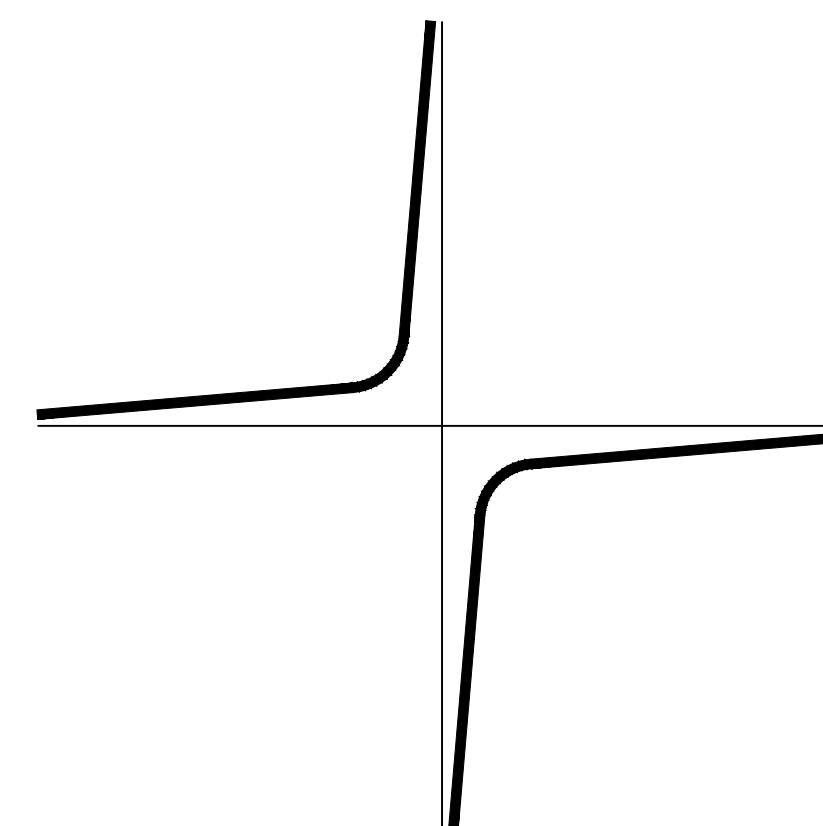

JOHN C. CARTER & CO., INC.
 LANDSCAPE ARCHITECTURE

960 BOSTON NECK RD., NARRAGANSETT, RI
 (401) 783 - 3500

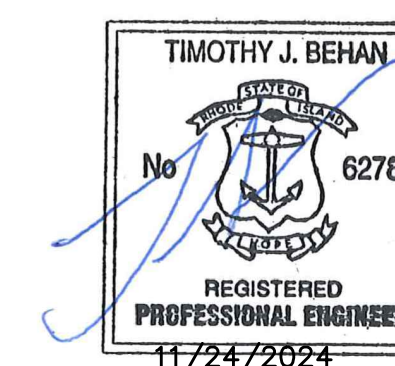

STATE/FEDERAL PERMITS:

1. RIDEM FRESHWATER WETLANDS (PERMIT #24-0231)
2. RIDEM RIPDES (SOIL EROSION) (PERMIT #RIR102718)
3. RIDEM OWTS SUBDIVISION SUITABILITY
4. RIDEM OWTS INDIVIDUAL LOTS

PERMIT AGENCY REVIEW SET

DRAWING ISSUE:

- CONCEPT
- CUSTOMER APPROVAL
- PERMITTING
- CONSTRUCTION
- AS-BUILT
- OTHER:

ONLY PLANS ISSUED FOR CONSTRUCTION SHALL BE USED FOR CONSTRUCTION

ABBREVIATIONS

APPROX	APPROXIMATE
BIT	BITUMINOUS
BOT	BOTTOM
CB	CATCH BASIN
CE	CEMENT
CF	CUBIC FEET
CFS	CUBIC FEET PER SECOND
CL	CENTERLINE
CL##	PRESSURE RATING CLASS
CLDI	CEMENT-LINED DUCTILE IRON
CONC	CONCRETE
CY	CUBIC YARD
DMH	DRAIN MANHOLE
ELEV	ELEVATION
EX	EXISTING
ESHGWT	ESTIMATED SEASONAL HIGH GROUNDWATER TABLE
GWT	GROUNDWATER TABLE
GG	GAS GATE VALVE
HDPE	HIGH-DENSITY POLYETHYLENE
HMA	HOT MIX ASPHALT
INV	INVERT
L	LENGTH
LOD	LIMIT OF DISTURBANCE
MAX	MAXIMUM
MIN	MINIMUM
PROP	PROPOSED
PVC	POLY-VINYL CHLORIDE
PSI	POUNDS PER SQUARE INCH (PRESSURE RATING)
R&D	REMOVE & DISPOSE
R&R	REMOVE & RESET
R&S	REMOVE & STOCKPILE (STORE)
RCP	REINFORCED CONCRETE PIPE
SCH	SCHEDULE (PIPES)
SDR	STANDARD DIMENSION RATIO
SED	SEDIMENT
SESC	SOIL EROSION & SEDIMENTATION CONTROL
SF	SQUARE FEET
SMH	SEWER MANHOLE
SY	SQUARE YARD
TEMP	TEMPORARY
TH	TEST HOLE
TYP	TYPICAL
VERT	VERTICAL
W	WIDTH
WQ	WATER QUALITY
YR	YEAR
'	FEET
"	INCHES
'/	VERTICAL FEET/HORIZONTAL FOOT

SITE NOTES:

- EXISTING PARCEL (A.P. 33 LOT 24) CONSIST OF 16.50±ACRES THAT ARE ZONED R-40.
- WETLAND FLAGS DELINEATED BY AVIZNIS ENVIRONMENTAL SERVICES, INC. 2022.
- OFF SITE BUILDING LOCATIONS ARE APPROXIMATE AND HAVE BEEN TAKEN FROM AERIAL PHOTOGRAPHY.
- ABUTTING PROPERTY OWTS' TAKEN FROM PLANS OF RECORD.
- ELEVATIONS BASED ON NAVD88 VERTICAL DATUM.
- A SMALL PORTION OF SUBJECT SITE IS SITUATED IN FEMA 100-YR FLOOD ZONE 'A' AS DEPICTED ON MAP 44009C02011, EFFECTIVE 4/3/2020. THE REMAINING PORTION OF THE SITE IS SITUATED IN ZONE 'X' WHICH IS AREA OF MINIMAL FLOOD HAZARD.
- THERE ARE NO EXISTING, ACTIVE AREAS OF AGRICULTURAL USE.
- THE BmA SOIL TYPE IS CONSIDERED A 'PRIME AGRICULTURAL SOIL'.
- SUBJECT SITE LIES IN THE 'SAUGATUCKET RIVER' SUB WATERSHED. THERE ARE NO BOUNDARY LINE IN SUBJECT SITE OR IN THE IMMEDIATE AREA.
- THERE ARE NO KNOWN ROCK OUTCROPPINGS, CLIFFS OR COASTAL FEATURES ON SUBJECT SITE.
- THERE ARE NO KNOWN STREETS, DRIVEWAYS, FARM ROADS, WOOD ROADS AND/OR TRAILS THAT HAVE BEEN IN PUBLIC USE.
- THERE ARE NO KNOWN CEMETERIES ON OR IMMEDIATELY ADJACENT TO SUBJECT PROPERTY.
- THERE ARE NO KNOWN UNIQUE NATURAL FEATURES ON SUBJECT SITE.
- SUBJECT SITE IS SITUATED IN A NATURAL HERITAGE AREA AND TMDL WATERSHED AND IS NOT SITUATED IN A SAMP PLAN AREA, S.K. GROUND WATER PROTECTION OVERLAY DISTRICT, RIDEM OWTS CRITICAL RESOURCE AREA, AND DRINKING WATER SUPPLY WATERSHED.
- SUBJECT PARCEL AND STRUCTURES IS NOT LISTED ON THE NATIONAL REGISTER OF HISTORIC PLACES.
- THIS IS NOT A SURVEY BOUNDARY PLAN, REFER TO SURVEY PLAN AT THE REAR OF THE PLAN SET. SURVEY INFORMATION PROVIDED BY COMMONWEALTH LAND SURVEYORS, INC.

GENERAL NOTES:

- THESE PLANS HAVE BEEN ISSUED FOR LOCAL AND/OR STATE AGENCY REVIEW. ONLY PLANS STAMPED 'ISSUED FOR CONSTRUCTION' AFTER RECEIPT OF ALL LOCAL AND STATE APPROVALS SHALL BE USED FOR CONSTRUCTION.
- SPECIFICATIONS & DETAILS GOVERNING THIS PROJECT ARE THE RHODE ISLAND STANDARD SPECIFICATIONS FOR ROAD & BRIDGE CONSTRUCTION, AUGUST 2023 EDITION & TOWN OF SOUTH KINGSTOWN SUBDIVISION & LAND DEVELOPMENT STANDARDS. THE TOWN'S STANDARDS SHALL OVERRIDE RIDOT STANDARDS OUTSIDE OF STATE R.O.W.'S.
- THE CONTRACTOR SHALL READ AND FAMILIARIZE ITSELF WITH THE TOWN'S SUBDIVISION & LAND DEVELOPMENT REGULATIONS (AS THEY PERTAIN TO CONSTRUCTION) PRIOR TO CONSTRUCTION.
- ANY REQUIRED AUTHORIZATION/PERMITS TO PERFORM WORK NOT PREVIOUSLY SECURED & PROVIDED BY THE OWNER SHALL BE OBTAINED BY THE CONTRACTOR PRIOR TO THE START OF CONSTRUCTION. THE CONTRACTOR SHALL ADHERE TO THE TERMS, CONDITIONS AND REQUIREMENTS OF ALL STATE & LOCAL PERMITS ISSUED FOR THE PROJECT.
- THE CONTRACTOR SHALL BE SOLELY RESPONSIBLE FOR ANY CONSTRUCTION OPERATIONS, INCLUDING ALL ACTIONS OR OMISSIONS OF ANY SUBCONTRACTORS, AGENTS OR EMPLOYEES. THE CONTRACTOR IS ALSO RESPONSIBLE FOR ALL ASPECTS OF ON-SITE SAFETY, INCLUDING ANY DAMAGE TO EXISTING STRUCTURES.
- ALL ELEVATIONS ON SUBJECT PROPERTY ARE BASED ON NAVD88 DATUM, AND HAVE A POTENTIAL VERTICAL VARIANCE OF 1± FEET.
- NO EXISTING DRAINAGE STRUCTURE OR FACILITY SHALL BE ALTERED OR DISTURBED UNLESS SPECIFICALLY INDICATED ON THESE DRAWINGS. ANY DAMAGE TO EXISTING UTILITIES SHALL BE THE CONTRACTOR'S SOLE RESPONSIBILITY TO REPAIR.
- ALL DISTURBED AREAS/STRUCTURES SHALL BE REPLACED IN-KIND, UNLESS OTHERWISE SHOWN OR AUTHORIZED BY THE TOWN.
- THE CONTRACTOR SHALL THOROUGHLY EXAMINE THE CONTRACT DOCUMENTS AND PLANS, AND SHALL INSPECT THE SITE, ANY CHANGES TO THE PROJECT, OR THE INSTALLATION OF AN ITEM FOR WHICH NO PARTICULAR DETAIL OR SPECIFICATION WAS PROVIDED, SHALL BE REVIEWED BY, AND MUST BE ACCEPTABLE TO, THE ENGINEER.
- THE ABSENCE OF PARTICULAR DETAILS OR SPECIFICATIONS FOR WORK CALLED FOR ON THE PLANS SHALL NOT RELIEVE THE CONTRACTOR FROM FURNISHING AND INSTALLING THE PROPOSED WORK.
- ALL CONSTRUCTION IS SUBJECT TO THE INSPECTION OF AND APPROVAL BY THE TOWN. PROPER NOTIFICATION SHALL BE GIVEN PRIOR TO THE COMMENCEMENT OF ANY WORK, AND NO WORK SHALL PROCEED WITHOUT THE AUTHORIZATION OF THE TOWN.
- PRIOR TO THE START OF CONSTRUCTION, THE APPROVED LIMIT OF DISTURBANCE SHALL BE LOCATED AND FIELD-DELIMITED BY A R.I. PLS; NO CLEARING OR DISTURBANCE SHALL TAKE PLACE OUTSIDE THE ESTABLISHED LIMIT AT ANY POINT DURING CONSTRUCTION, UNLESS EXPLICITLY AUTHORIZED BY THE TOWN.
- PRIOR TO THE START OF EARTH-DISTURBING ACTIVITIES, THE CONTRACTOR SHALL INSTALL ALL SEDIMENT & SOIL EROSION CONTROL (SESC) DEVICES IN ACCORDANCE WITH RIDEM & TOWN STANDARDS.
- THE LOCATION, SIZE AND SHAPE OF BUILDINGS AND DRIVEWAYS ARE DEPICTED TO DEMONSTRATE CONFORMANCE WITH VARIOUS STATE AND LOCAL SITE REQUIREMENTS FOR PERMITTING PURPOSES. THESE MAY VARY ACCORDING TO OWNER PREFERENCES AND PERMITTING APPROVALS, EXCEPT THAT UNDER NO CIRCUMSTANCES SHALL ANY BUILDINGS BE ALLOWED BEYOND THE LIMITS OF DISTURBANCE OR THE BUILDING SETBACK LINES SHOWN ON THESE PLANS.
- COMMUNICATION LINES (ELECTRIC, TELEPHONE, AND CABLE TV) SHALL BE INSTALLED UNDERGROUND, UNLESS OVERHEAD SERVICE IS APPROVED BY THE TOWN.
- ALL ROOT SYSTEMS, TREES, STUMPS, BUSHES, BOULDERS, EXISTING CONCRETE FOUNDATIONS AND OTHER UNSUITABLE MATERIAL SHALL BE REMOVED AND TRANSPORTED AWAY FROM THE PROJECT SITE TO A LEGAL DISPOSAL LOCATION, UNLESS ON-SITE DISPOSAL AT AN APPROPRIATE LOCATION (OR LOCATIONS) IS APPROVED BY THE TOWN.

EXISTING CONDITIONS/UTILITIES NOTES:

- THE CONTRACTOR SHALL VERIFY THE LOCATIONS OF ALL EXISTING DRAINAGE AND UTILITIES, BOTH UNDERGROUND AND OVERHEAD BEFORE EXCAVATION BEGINS IN ACCORDANCE WITH 'DIG SAFE'.
- NO DRAINAGE STRUCTURE OR FACILITY SHALL BE DISTURBED WITHOUT PROPER PERMITS UNLESS SPECIFICALLY INDICATED ON THESE DRAWINGS. ANY DAMAGE TO EXISTING UTILITIES SHALL BE THE CONTRACTOR'S RESPONSIBILITY.
- ALL EXISTING UTILITIES HAVE BEEN PLOTTED BASED UPON THE BEST INFORMATION AVAILABLE AT THE TIME OF PLAN PREPARATION AND REPRESENT APPROXIMATE LOCATIONS. SOME OBSTRUCTIONS, OBSTACLES, OR DIFFICULTIES IN THE PATH OF THE WORK, EITHER ANTICIPATED OR DISCOVERED IN THE PERFORMANCE OF THE WORK, MAY NOT HAVE BEEN INDICATED BY DRAWINGS. THE CONTRACTOR SHALL BE UNDERSTOOD TO HAVE ENTERED INTO THE CONTRACT WITH FULL KNOWLEDGE THAT IN ANY WORK INVOLVED IN CONSTRUCTION OPERATIONS IN PUBLIC HIGHWAYS OR ADJACENT TO OTHER DEVELOPMENTS, SOME UNFORESEEN OBSTACLES, DIFFICULTIES, SOIL OR GROUND WATER CONDITIONS, ETC., MAY BE ENCOUNTERED, AND THAT THE CONTRACTOR HAS INCLUDED IN HIS BID AND CONTRACT OBLIGATIONS THE ASSUMPTIONS OF THE RISKS AND COSTS TO WHICH SUCH OBSTACLES, ETC. MAY SUBJECT HIM/HER.
- THE LOCATION OF EXISTING UNDERGROUND PIPES, CONDUITS, AND STRUCTURES AS SHOWN HAS BEEN COLLECTED FROM THE BEST AVAILABLE SOURCES, AND THE OWNER, TOGETHER WITH HIS AGENTS, DOES NOT IMPLY OR GUARANTEE THE DATA AND INFORMATION IN CONNECTION WITH UNDERGROUND PIPES, CONDUITS, STRUCTURES, AND SUCH OTHER PARTS, AS TO THEIR COMPLETENESS, NOR THEIR LOCATIONS AS INDICATED. THE CONTRACTOR SHALL ASSUME THAT THERE ARE EXISTING WATER, GAS AND OTHER UTILITY CONNECTIONS IN ROUTE, WHETHER THEY APPEAR ON THE DRAWINGS OR NOT. ANY EXPENSE AND/OR DELAY OCCASIONED BY UTILITIES AND STRUCTURES OR DAMAGE THERETO, INCLUDING THOSE NOT SHOWN, SHALL BE THE RESPONSIBILITY OF THE CONTRACTOR, AT NO ADDITIONAL EXPENSE TO THE OWNER.
- BEFORE PROCEEDING WITH CONSTRUCTION OPERATIONS, THE CONTRACTOR SHALL MAKE SUCH SUPPLEMENTAL INVESTIGATIONS, INCLUDING EXPLORATORY EXCAVATIONS BY HAND DIGGING, AS THEY DEEM NECESSARY TO UNCOVER AND DETERMINE THE EXACT LOCATIONS OF UTILITIES AND STRUCTURES OR DAMAGE THERETO, INCLUDING THOSE NOT SHOWN, SHALL BE THE RESPONSIBILITY OF THE CONTRACTOR, AT NO ADDITIONAL EXPENSE TO THE OWNER.
- PRIOR TO CONSTRUCTION THE CONTRACTOR SHALL ENGAGE A R.I. PROFESSIONAL LAND SURVEYOR TO SET AND VERIFY ALL LINES AND GRADES. ALL EXISTING AND PROPOSED UTILITY LOCATIONS AND ELEVATIONS ARE TO BE CONFIRMED BY THE CONTRACTOR PRIOR TO CONSTRUCTION. ANY ITEM FOUND WHICH DOES NOT MATCH THE PLANS WILL BE BROUGHT TO THE ENGINEER'S ATTENTION PRIOR TO CONSTRUCTION FOR REVIEW.
- ANY DAMAGE TO EXISTING PAVEMENT, BRIDGES, CONDUIT, SIDEWALK, FENCES, ETC., CAUSED BY THE CONTRACTOR SHALL BE REPAIRED BY THE CONTRACTOR AT NO ADDITIONAL COST TO THE OWNER/STATE/CITY.
- WHENEVER IT MAY BE NECESSARY TO CROSS OR INTERFERE WITH EXISTING CULVERTS, DRAINS, SEWERS, WATER PIPES, FIXTURES, GUARDRAILS, FENCES, GAS PIPES, OR OTHER STRUCTURES NEEDING SPECIAL CARE, DUE NOTICE SHALL BE GIVEN TO THE OWNER. WHENEVER REQUIRED, ALL OBJECTS SHALL BE STRENGTHENED TO MEET ANY ADDITIONAL STRESS THAT THE WORK HEREIN SPECIFIED MAY IMPOSE UPON IT, AND ANY DAMAGE CAUSED SHALL BE THOROUGHLY REPAIRED. THE ENTIRE WORK SHALL BE PERFORMED AT NO EXPENSE TO THE OWNER. THE CONTRACTOR SHALL BE RESPONSIBLE FOR ALL BROKEN MAINS OR UTILITIES ENCOUNTERED DURING THE PROGRESS OF THE WORK AND SHALL REPAIR AND BE RESPONSIBLE FOR CORRECTING ALL DAMAGES TO EXISTING UTILITIES, STRUCTURES AND PERSONAL "PROPERTY" WHICH MAY HAVE BEEN CAUSED BY BROKEN LINES AT NO ADDITIONAL COST TO THE OWNER. THE CONTRACTOR SHALL CONTACT THE PROPER UTILITY OR AUTHORITY TO CORRECT OR MAKE ANY CHANGES DUE TO UTILITIES OR OTHER OBSTRUCTIONS DURING CONSTRUCTION, BUT THE ENTIRE RESPONSIBILITY AND EXPENSE SHALL BE WITH THE CONTRACTOR. ALL DAMAGED ITEMS OF WORK OR ITEMS REQUIRED TO BE REMOVED AND REPLACED DUE TO CONSTRUCTION SHALL BE REPLACED OR REPAIRED BY THE CONTRACTOR TO THE COMPLETE SATISFACTION OF THE OWNER, AND AT NO ADDITIONAL EXPENSE TO THE OWNER.

GROUNDWATER REMOVAL & PROTECTION FROM FLOODING:

- SOME EXCAVATIONS FOR PIPELINES, STRUCTURES, AND APPURTENANT WORK REQUIRED MAY OCCUR BELOW EXISTING GROUNDWATER LEVELS.
- THE CONTRACTOR SHALL CONSTRUCT AND MAINTAIN ALL PUMPS, DRAINS, WELL POINTS AND/OR ANY OTHER FACILITIES FOR THE CONTROL, COLLECTION, AND DISPOSAL OF GROUNDWATER OR SURFACE AND SUBSURFACE WATER ENCOUNTERED IN THE PERFORMANCE OF THE WORK, AND SHALL PROVIDE ALL PUMPS, PIPING, AND DITCHING FOR THE REMOVAL OF WATER FROM THE TRENCHES AND EXCAVATIONS SO THAT ALL TRENCHES AND EXCAVATIONS MAY BE KEPT FREE FROM WATER AT ALL TIMES, AND SO THAT THE WORK MAY BE PERFORMED IN THE DRY.
- DEWATERING OF EXCAVATIONS SHALL BE ACCOMPLISHED BY METHODS THAT HAVE BEEN APPROVED PRIOR TO COMMENCEMENT OF WORK BY THE ENGINEER, AND WHICH HAVE A BACKGROUND OF SUCCESSFUL DEWATERING OF EXCAVATIONS OF THE TYPE TO BE EMPLOYED FOR THE WORK.
- PUMPING SHALL BE CONTINUOUS WHERE DIRECTED AND/OR AS NECESSARY TO PROTECT THE WORK, AND TO MAINTAIN SATISFACTORY PROGRESS OF SAME.
- THE CONTRACTOR'S DEWATERING AND PUMPING OPERATIONS SHALL BE CARRIED OUT IN SUCH A MANNER THAT NO LOSS OF GROUND WILL RESULT FROM THESE OPERATIONS. ANY DAMAGE TO EXISTING FEATURES OR TO THE CONTRACT WORK RESULTING FROM THE CONTRACTOR'S DEWATERING OPERATIONS SHALL BE REPAIRED BY THE CONTRACTOR, AS DIRECTED BY THE OWNER, AT NO ADDITIONAL EXPENSE TO THE OWNER. PRECAUTIONS SHALL BE TAKEN TO PROTECT NEW AND EXISTING WORK FROM FLOODING OR DAMAGE DURING STORMS OR OTHER CAUSES.
- ALL PIPELINES OR STRUCTURES NOT STABLE AGAINST UPLIFT DURING CONSTRUCTION OR PRIOR TO COMPLETION SHALL BE THOROUGHLY BRACED OR OTHERWISE PROTECTED.
- WATER FROM THE TRENCHES, EXCAVATIONS, AND DRAINAGE OPERATIONS SHALL BE DISPOSED OF IN SUCH A MANNER AS WILL CAUSE NEITHER INJURY TO PUBLIC HEALTH OR PRIVATE PROPERTY, NOR DAMAGE TO THE WORK COMPLETED OR IN PROGRESS. THE CONTRACTOR SHALL CONSTRUCT DITCHES, ESTABLISH GRADING, AND PERFORM ANY AND ALL OTHER WORK AS MAY BE NECESSARY TO DIVERT AND PREVENT SURFACE WATER AND WATER FROM DEWATERING OPERATIONS FROM ENTERING EXCAVATION AND WORK AREAS.

SUBSURFACE CONDITIONS NOTES:

- ALL SOIL AND TEST HOLE DATA, WATER TABLE ELEVATIONS, AND SOIL ANALYSIS SHOWN/REFERENCED ON THE DRAWINGS OR INCLUDED IN THE SPECIFICATIONS APPLY ONLY AT THE LOCATION OF THE TEST HOLES AND TO THE DEPTHS INDICATED. SOIL TEST REPORTS ARE AVAILABLE FOR INSPECTION AT THE OFFICE OF THE DESIGN ENGINEER. ANY ADDITIONAL SUBSURFACE EXPLORATION SHALL BE DONE BY THE CONTRACTOR AT THEIR OWN EXPENSE. IT IS UNDERSTOOD THAT THE MAKING OF THE DEDUCTIONS, INTERPRETATIONS AND CONCLUSIONS FROM ALL THE ACCESSIBLE FACTUAL INFORMATION, INCLUDING THE NATURE OF THE MATERIALS TO BE EXCAVATED, THE DIFFICULTIES OF MAKING AND MAINTAINING THE REQUIRED EXCAVATIONS, AND THE DIFFICULTIES OF DOING OTHER WORK AFFECTED BY THE GEOLOGY AND OTHER SUBSURFACE CONDITIONS AT THE SITE OF THE WORK, ARE THE CONTRACTOR'S SOLE RESPONSIBILITY.
- THE INDICATED ELEVATION OF THE WATER TABLE IS THAT EXISTING AT THE DATE THE TEST HOLE DATA WAS DETERMINED. IT IS THE CONTRACTOR'S RESPONSIBILITY TO DETERMINE AND ALLOW FOR THE ELEVATION OF GROUNDWATER AT THE DATE OF PROJECT CONSTRUCTION. A DIFFERENCE IN ELEVATION BETWEEN GROUNDWATER SHOWN IN SOIL LOGS AND GROUNDWATER ACTUALLY ENCOUNTERED DURING CONSTRUCTION WILL NOT BE CONSIDERED AS A BASIS FOR EXTRA WORK.
- ESTIMATED SEASONAL HIGH WATER TABLES ARE FOR CONSTRUCTION OF ON-SITE WASTEWATER TREATMENT SYSTEMS ONLY AND SHOULD NOT BE USED FOR ANY OTHER PURPOSE. ESTIMATED SEASONAL HIGH WATER TABLES WILL BE EXCEEDED FREQUENTLY.

CONSTRUCTION NOTES:

- DEVELOPER SHALL RETAIN THE SERVICES OF A RHODE ISLAND PROFESSIONAL ENGINEER TO REVIEW AND APPROVE SHOP DRAWINGS, SAMPLES, AND OTHER SUBMITTALS OF THE CONTRACTOR FOR CONFORMANCE WITH THE DESIGN CONCEPT (THIS PLAN SET) AND CITY REGULATIONS, WHICH INCLUDE (BUT ARE NOT LIMITED TO) THE FOLLOWING:
 - DRAINAGE SYSTEM SHOP DRAWINGS/SKETCHES FOR PIPE, PIPE JOINTS, PIPE BEDDING/BACKFILL MATERIALS (SEVE ANALYSIS, ETC.), COMPACTION METHODS, MANHOLE STRUCTURES, FRAME & COVERS, FRAME & GRATES, FRAME & COVER ADJUSTMENT METHODS TO FINISH GRADE, PROPOSED RIM ELEVATIONS, PIPE INVERTS AND PIPE DIAMETERS. ANY SUBSTANTIAL CHANGES TO THE DESIGN CONCEPT SHALL BE BROUGHT TO THE CITY'S ATTENTION.
 - ROADWAY CONSTRUCTION SHOP DRAWINGS/SKETCHES FOR GRAVEL BASE MATERIALS, BITUMINOUS CONCRETE COURSES, SIGNAGE/STRIPING, UNDERDRAINS, GUARDRAILS, RETAINING WALLS AND CURBING/BERMS.
 - SOIL EROSION CONTROL AND DEWATERING METHODS.
 - COMPACTION METHODS FOR INSTALLING PIPE/MANHOLES, GRAVEL ROAD BASE AND BITUMINOUS CONCRETE COURSES.
 - TESTING METHODS AND TESTING FREQUENCY FOR DRAINAGE AND ROAD BASE SYSTEMS. TESTING FREQUENCY SHALL BE IN ACCORDANCE WITH RIDOT AND TYPICAL ENGINEERING STANDARDS.
- THE SHOP DRAWING SUBMITTAL PACKAGE SHALL BE STAMPED BY A RHODE ISLAND PROFESSIONAL ENGINEER AND SUBMITTED TO THE TOWN/TOWN ENGINEER FOR REVIEW AND APPROVAL. SHOP DRAWING RECORDS SHALL BE MAINTAINED FOR THE DURATION OF THE PROJECT, INCLUDING THE WARRANTY PERIOD.
- MARKED-UP CONSTRUCTION DRAWINGS SHALL BE MAINTAINED AND KEPT AT THE JOB SITE FOR THE DURATION OF THE PROJECT.
- THE CONTRACTOR SHALL PREPARE AND SUBMIT AS-BUILT DRAWINGS IN ACCORDANCE WITH TOWN REGULATIONS AND VEOLIA WATER RHODE ISLAND INC.(VEOLIA). AS-BUILT DRAWING SHALL COMPLY WITH VEOLIA RULES AND REGULATIONS. AS-BUILT SHALL BE STAMPED BY A R.I. PROFESSIONAL LAND SURVEYOR AND R.I. PROFESSIONAL ENGINEER.
- PRIOR TO ACCEPTANCE OF INFRASTRUCTURE, A R.I. P.E. SHALL CERTIFY THE INFRASTRUCTURE WAS INSTALLED IN ACCORDANCE WITH THE DESIGN INTENT AND MEETS RIDOT/TOWN STANDARDS & PERMIT STIPULATIONS, AND IS READY FOR USE. AS-BUILT DRAWING SHALL COMPLY WITH VEOLIA RULES AND REGULATIONS AND BE ACCEPTED AND APPROVED BY VEOLIA.

EARTHWORK NOTES:

- THE CONTRACTOR SHALL CONTACT 'DIGSAFE' AT 1-888-344-7233 AT LEAST 72 HOURS PRIOR TO ANY EXCAVATION OR CONSTRUCTION.
- SPECIFICATIONS & DETAILS TO GOVERN THIS PROJECT ARE THE RHODE ISLAND STANDARD SPECIFICATIONS FOR ROAD & BRIDGE CONSTRUCTION – AUGUST 2023 EDITION (INCLUDING ALL SUBSEQUENT ADDENDA) AS WELL AS TOWN STANDARDS; WHERE APPLICABLE, THE TOWN'S STANDARDS SHALL OVERRIDE RIDOT STANDARDS.
- RIDOT STANDARDS ARE AVAILABLE FOR DOWNLOAD FROM THE RIDOT WEBSITE UNDER 'STANDARDS AND SPECIFICATIONS' (WWW.DOT.STATE.RI.US/ENGINEERING/STANDARDS/INDEX.ASP).
- EMBANKMENT SLOPES AND ALL DISTURBED AREAS ARE TO RECEIVE 4" OF TOPSOIL AND GRASS SEED UNLESS OTHERWISE NOTED.
- ALL EXCAVATION AND PLACEMENT OF FILL SHALL BE IN ACCORDANCE WITH R.I.D.O.T. STANDARD SPECIFICATIONS SECTION 202 AND TOWN SUBDIVISION AND LAND DEVELOPMENT REGULATIONS. ALL MATERIALS AND METHODS SHALL BE PERFORMED IN ACCORDANCE WITH THESE STANDARDS AND SPECIFICATIONS. ALL FILL BENEATH PAVEMENTS SHALL BE GRAVEL AS DEFINED IN THE RIDOT SPECIFICATIONS.
- ALL AREAS COMPACTED BY CONSTRUCTION ACTIVITIES (OTHER THAN ROADWAYS AND BENEATH STRUCTURES) SHALL BE RESTORED TO PROMOTE INFILTRATION BY TILLING THE TOP 12 INCHES OF SOIL PRIOR TO FINAL STABILIZATION.
- ALL UNSUITABLE MATERIAL (LOAM, SUBSOIL, ROOTS, TREE TRUNKS, CLAY, SILT, ORGANIC MATTER, LARGE STONES, ETC.) SHALL BE REMOVED FROM THE ROADWAY SUBGRADE AND EMBANKMENT AREAS PRIOR TO THE PLACEMENT OF THE GRAVEL SUBBASE/BERM MATERIAL AS DIRECTED AND APPROVED.
- SUITABLE SURPLUS MATERIAL GENERATED BY EXCAVATIONS WITHIN THE PROJECT AREA (SAND, GRAVEL, LOAM, ETC.) SHALL BE RE-USED, TO THE EXTENT POSSIBLE, IN OTHER LOCATIONS WITHIN THE PROJECT AREA; MINING OF SITE MATERIALS (I.E. REMOVAL OF SUITABLE IN-SITU MATERIALS FROM THE SITE AND REPLACEMENT WITH IMPORTED BORROW MATERIALS) SHALL NOT BE PERMITTED.

MAINTENANCE AND PROTECTION OF TRAFFIC NOTES:

- THE CONTRACTOR SHALL BE RESPONSIBLE FOR MAINTENANCE AND PROTECTION OF PEDESTRIAN AND VEHICULAR TRAFFIC DURING CONSTRUCTION, INCLUDING POLICE PROTECTION. ALL TEMPORARY AND VEHICULAR SIGNS, BARRICADES AND LANE CLOSURES SHALL BE IN CONFORMANCE WITH THE MAY 2012 MANUAL OF UNIFORM TRAFFIC CONTROL DEVICES (MUTCD), INCLUDING ALL SUBSEQUENT REVISIONS.
- TEMPORARY CONSTRUCTION SIGNS AND ALL APPLICABLE TRAFFIC CONTROL DEVICES SHALL BE IN PLACE PRIOR TO THE START OF WORK IN ANY AREA OPEN TO TRAFFIC.
- THE PRIVATE VEHICLES OF CONSTRUCTION WORKERS WILL NOT BE PARKED IN THE STREET RIGHT-OF-WAYS.
- SIGN MOUNTINGS SHALL BE IN ACCORDANCE WITH R.I.D.O.T. SPECIFICATIONS FOR TEMPORARY CONSTRUCTION SIGNS.

DRAWING ISSUE:

- CONCEPT
- CUSTOMER APPROVAL
- PERMITTING
- CONSTRUCTION
- AS-BUILT
- OTHER:

ONLY PLANS ISSUED FOR CONSTRUCTION SHALL BE USED FOR CONSTRUCTION

OWNER:

SHELEEN CLARKE
96 DUCK COVE ROAD
NORTH KINGSTOWN, RI 02852

APPLICANT:

NEW ENGLAND PROPERTIES, LLC
257 WICKFORD CT.
NORTH KINGSTOWN, RI 02852

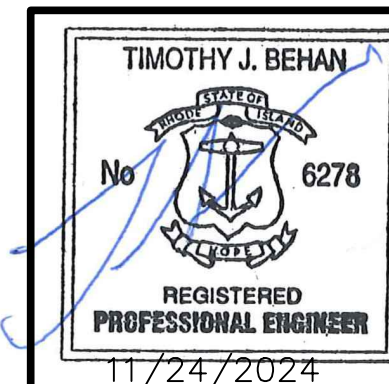

PERMIT AGENCY REVIEW PLAN
FOR
VILLAGE AT BROAD ROCK
PLAT 33, LOT 24
ON
BROAD ROCK ROAD
SOUTH KINGSTOWN, RHODE ISLAND
NOTES AND LEGEND PLAN

SCALE: AS SHOWN	SHEET NO: 2 OF 17	
DRAWN BY: SMA	DESIGN BY: SMA	CHECKED BY: TJB
DATE: FEBRUARY 2024	PROJECT NO 23011.00	

LEGEND

ABUTTER LINE	—————	BUILDING SETBACK LINE	-----
LOT LINE	=====	EXISTING CONTOUR	-----
EDGE OF ROAD PAVEMENT	-----	EXISTING SPOT GRADE	x123.0
RIGHT OF WAY CENTERLINE	-----	PROPOSED LOT CONTOUR	⊠
ROADWAY STATION	2+00	PROPOSED SPOT GRADE	X63.50
TEST HOLE	TH	DRAINAGE MANHOLE	● DMH
PERC TEST	PT	HYDRANT	⊗
LEDGE TEST	LT	DRAIN LINE	— D —
UTILITY POLE	—	WATERLINE	— W —
WETLAND EDGE	WF-A6 WF-A7	OVERHEAD WIRES	— OHW —
200' RIVER BUFFER ZONE	-----	UNDERGROUND ELECTRIC/TELE.	— E —
20' STRUCTURE SETBACK	-----	SOIL BOUNDARY LINE	-----
EXISTING STONEWALL	⊘⊘⊘⊘⊘⊘⊘⊘	FEMA 100-YR FLOOD ZONE	-----
UNDERGROUND TELE/COMM	— T —	CURB STOP	⊗
		WATER VALVE	⊗
		PROPOSED STONE WALL	⊘⊘⊘⊘⊘⊘⊘⊘

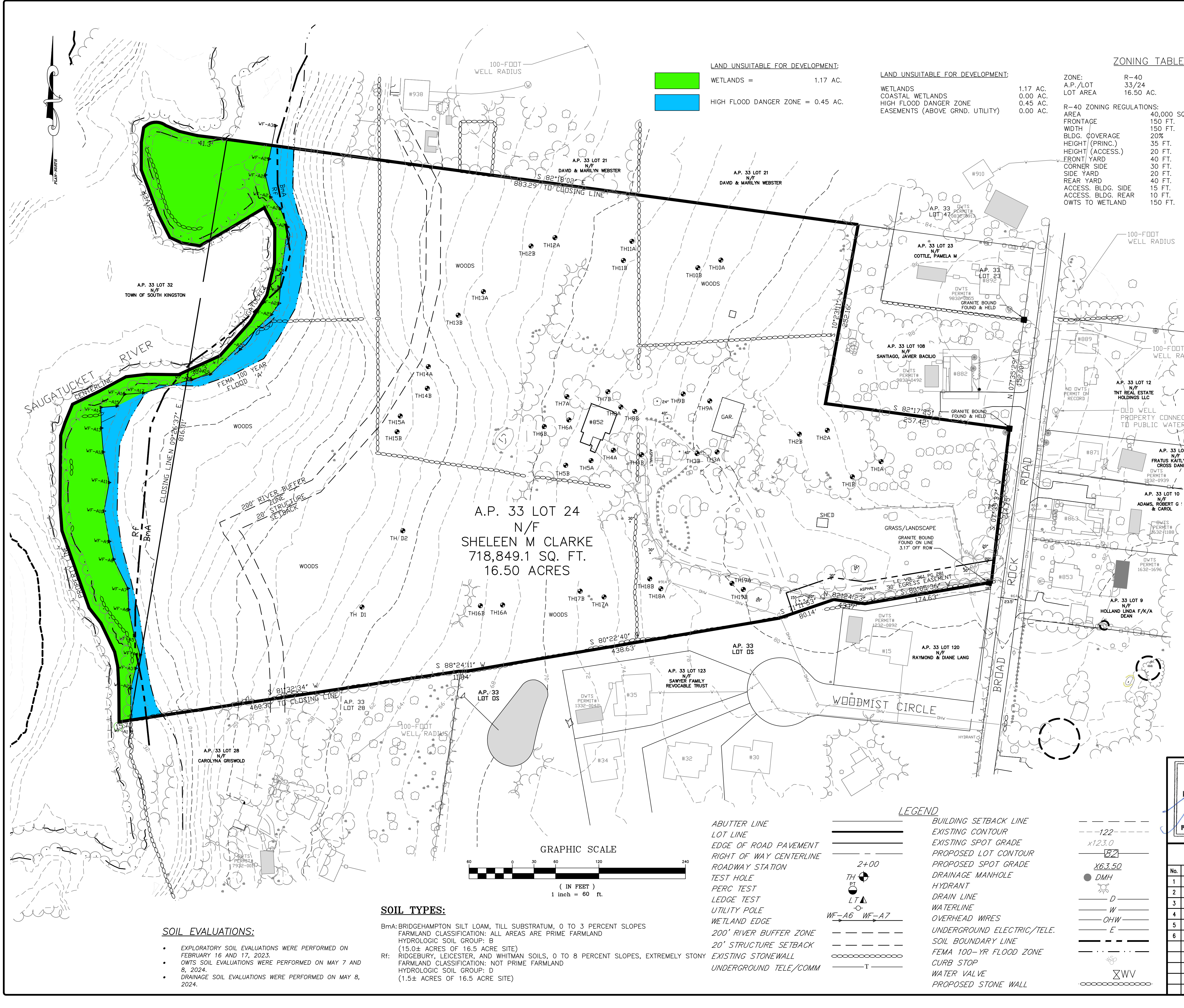

LAND UNSUITABLE FOR DEVELOPMENT:

WETLANDS = 1.17 AC.

HIGH FLOOD DANGER ZONE = 0.45 AC.

LAND UNSUITABLE FOR DEVELOPMENT:

WETLANDS 1.17 AC.

COASTAL WETLANDS 0.00 AC.

HIGH FLOOD DANGER ZONE 0.45 AC.

EASEMENTS (ABOVE GRND. UTILITY) 0.00 AC.

ZONING TABLE:

ZONE:	R-40
A.P./LOT:	33/24
LOT AREA:	16.50 AC.
R-40 ZONING REGULATIONS:	
AREA:	40,000 SQ. FT.
FRONTAGE:	150 FT.
WIDTH:	150 FT.
BLDG. COVERAGE:	20%
HEIGHT (PRINC.):	35 FT.
HEIGHT (ACCESS.):	20 FT.
FRONT YARD:	40 FT.
CORNER SIDE:	30 FT.
SIDE YARD:	20 FT.
REAR YARD:	40 FT.
ACCESS, BLDG. SIDE:	15 FT.
ACCESS, BLDG. REAR:	10 FT.
OWTS TO WETLAND:	150 FT.



LOCUS MAP
NOT TO SCALE

- NOTES:**
- EXISTING PARCEL (A.P. 33 LOT 24) CONSIST OF 16.50±ACRES THAT ARE ZONED R-40.
 - WETLAND FLAGS DELINEATED BY AVIZINS ENVIRONMENTAL SERVICES, INC. 2022.
 - OFF SITE BUILDING LOCATIONS ARE APPROXIMATE AND HAVE BEEN TAKEN FROM AERIAL PHOTOGRAPHY.
 - ABUTTING PROPERTY OWTS TAKEN FROM PLANS OF RECORD.
 - ELEVATIONS BASED ON NAVD88 VERTICAL DATUM.
 - A SMALL PORTION OF SUBJECT SITE IS SITUATED IN FEMA 100-YR FLOOD ZONE 'A' AS DEPICTED ON MAP 44009C0201J, EFFECTIVE 4/3/2020. THE REMAINING PORTION OF THE SITE IS SITUATED IN ZONE 'X' WHICH IS AREA OF MINIMAL FLOOD HAZARD.
 - THERE ARE NO EXISTING, ACTIVE AREAS OF AGRICULTURAL USE.
 - THE BmA SOIL TYPE IS CONSIDERED A 'PRIME AGRICULTURAL SOIL'.
 - SUBJECT SITE LIES IN THE 'SAUGATUCKET RIVER' SUB WATERSHED. THERE ARE NO BOUNDARY LINE IN SUBJECT SITE OR IN THE IMMEDIATE AREA.
 - THERE ARE NO KNOWN ROCK OUTCROPPINGS, CLIFFS OR COASTAL FEATURES ON SUBJECT SITE.
 - THERE ARE NO KNOWN STREETS, DRIVEWAYS, FARM ROADS, WOOD ROADS AND/OR TRAILS THAT HAVE BEEN IN PUBLIC USE.
 - THERE ARE NO KNOWN CEMETERIES OR IMMEDIATELY ADJACENT TO SUBJECT PROPERTY.
 - THERE ARE NO KNOWN UNIQUE NATURAL FEATURES ON SUBJECT SITE.
 - SUBJECT SITE IS SITUATED IN A NATURAL HERITAGE AREA AND TMDL WATERSHED AND IS NOT SITUATED IN A SAMP PLAN AREA, S.K. GROUND WATER PROTECTION OVERLAY DISTRICT, RIEM OWTS CRITICAL RESOURCE AREA, AND DRINKING WATER SUPPLY WATERSHED.
 - SUBJECT PARCEL AND STRUCTURES IS NOT LISTED ON THE NATIONAL REGISTER OF HISTORIC PLACES.
 - THIS IS NOT A SURVEY BOUNDARY PLAN, REFER TO SURVEY PLAN AT THE REAR OF THE PLAN SET. SURVEY INFORMATION PROVIDED BY COMMONWEALTH LAND SURVEYORS, INC.

SURVEY NOTE:

- THIS IS NOT A SURVEY BOUNDARY PLAN, REFER TO SURVEY PLAN AT THE REAR OF THE PLAN SET. SURVEY INFORMATION PROVIDED BY COMMONWEALTH LAND SURVEYORS, INC.

DRAWING ISSUE:

- CONCEPT
 - CUSTOMER APPROVAL
 - PERMITTING
 - CONSTRUCTION
 - AS-BUILT
 - OTHER:
- ONLY PLANS ISSUED FOR CONSTRUCTION SHALL BE USED FOR CONSTRUCTION

OWNER:

SHELEEN CLARKE
96 DUCK COVE ROAD
NORTH KINGSTOWN, RI 02852

APPLICANT:

NEW ENGLAND PROPERTIES, LLC
257 WICKFORD CT.
NORTH KINGSTOWN, RI 02852

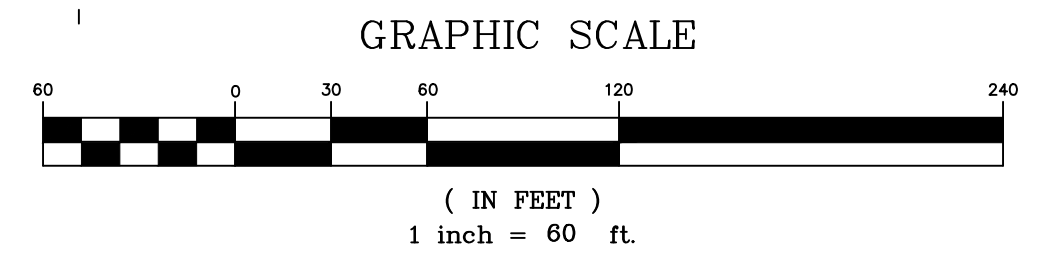

SOIL TYPES:

BmA: BRIDGEHAMPTON SILT LOAM, TILL SUBSTRATUM, 0 TO 3 PERCENT SLOPES
FARMLAND CLASSIFICATION: ALL AREAS ARE PRIME FARMLAND
HYDROLOGIC SOIL GROUP: B
(15.0± ACRES OF 16.5 ACRE SITE)

Rt: RIDGEBURY, LEICESTER, AND WHITMAN SOILS, 0 TO 8 PERCENT SLOPES, EXTREMELY STONY
FARMLAND CLASSIFICATION: NOT PRIME FARMLAND
HYDROLOGIC SOIL GROUP: D
(1.5± ACRES OF 16.5 ACRE SITE)

- SOIL EVALUATIONS:**
- EXPLORATORY SOIL EVALUATIONS WERE PERFORMED ON FEBRUARY 16 AND 17, 2023.
 - OWTS SOIL EVALUATIONS WERE PERFORMED ON MAY 7 AND 8, 2024.
 - DRAINAGE SOIL EVALUATIONS WERE PERFORMED ON MAY 8, 2024.

LEGEND

- ABUTTER LINE
- LOT LINE
- EDGE OF ROAD PAVEMENT
- RIGHT OF WAY CENTERLINE
- ROADWAY STATION
- TEST HOLE
- PERC TEST
- LEDGE TEST
- UTILITY POLE
- WETLAND EDGE
- 200' RIVER BUFFER ZONE
- 20' STRUCTURE SETBACK
- EXISTING STONEWALL
- UNDERGROUND TELE/COMM
- BUILDING SETBACK LINE
- EXISTING CONTOUR
- EXISTING SPOT GRADE
- PROPOSED LOT CONTOUR
- PROPOSED SPOT GRADE
- DRAINAGE MANHOLE
- HYDRANT
- DRAIN LINE
- WATERLINE
- OVERHEAD WIRES
- UNDERGROUND ELECTRIC/TELE.
- SOIL BOUNDARY LINE
- FEMA 100-YR FLOOD ZONE
- CURB STOP
- WATER VALVE
- PROPOSED STONE WALL

TIMOTHY J. BEHAN
REGISTERED PROFESSIONAL ENGINEER
No. 6278
11/24/2024

COMMONWEALTH ENGINEERS & CONSULTANTS, INC.
400 SMITH STREET
PROVIDENCE, RHODE ISLAND 02908
(401) 273-6600

REVISIONS

No.	DATE	DRWN	CHKD
1	4/2/24	TB	TB
2	4/18/24	TB	TB
3	9/6/24	SMA	TB
4	9/30/24	SMA	TB
5	10/21/24	SMA	TB
6	11/24/24	SMA	TB

PERMIT AGENCY REVIEW PLAN
FOR
VILLAGE AT BROAD ROCK
PLAT 33, LOT 24
ON
BROAD ROCK ROAD
SOUTH KINGSTOWN, RHODE ISLAND
EXISTING CONDITIONS PLAN

SCALE: AS SHOWN	SHEET NO: 3 OF 17	
DRAWN BY: SMA	DESIGN BY: SMA	CHECKED BY: TJB
DATE: FEBRUARY 2024	PROJECT NO 23011.00	

LAND UNSUITABLE FOR DEVELOPMENT:
 WETLANDS = 1.17 AC.
 HIGH FLOOD DANGER ZONE = 0.45 AC.

OPEN SPACE CALCULATIONS:
 CALCULATIONS PERFORMED IN ACCORDANCE WITH SUBDIVISION AND LAND DEVELOPMENT REGULATIONS, ARTICLE IV, A, 11:
 TOTAL LAND AREA = 16.50 ACRES
 LAND UNSUITABLE FOR DEVELOPMENT = 1.62 ACRES
 LAND SUITABLE FOR DEVELOPMENT = 14.88 ACRES
 R-40 ZONE REQUIRES 50% OF LAND SUITABLE FOR DEVELOPMENT TO BE OPEN SPACE.
 OPEN SPACE REQUIRED = 14.88 X 50% = 7.44 ACRES
 TOTAL OPEN SPACE PROVIDED = 10.06 ACRES
 SUBTRACT OUT 1) LAND SUITABLE FOR DEVELOPMENT AND 2) STORMWATER AREAS. OPEN SPACE PROVIDED = 10.04 - 1.62 - 0.77 = 7.65 AC. > 7.44 AC.
 % OPEN SPACE MORE THAN THE MINIMUM = 2.7%

DENSITY CALCULATIONS:
 YIELD PLAN = 13 LOTS
INCLUSIONARY INCENTIVE BONUS:
 IN ACCORDANCE WITH RI GENERAL LAW §45-24-46.1.C, FOR EACH INCLUSIONARY LOT PROVIDED, 2 MARKET RATE LOTS SHALL BE PROVIDED AS A DENSITY BONUS.
 3 AFFORDABLE LOTS ARE PROVIDED; THEREFORE, 6 ADDITIONAL MARKET RATE LOTS ARE PROVIDED.
TOTAL LOTS = 13 + 6 = 19 LOTS
 LOTS 6, 11 AND 18 SHALL BE AFFORDABLE HOUSING LOTS

ZONING TABLE:
 ZONE: R-40
 A.P./LOT: 33/24
 LOT AREA: 16.50 AC.
 R-40 ZONING REGULATIONS:
 AREA: 40,000 SQ. FT.
 FRONTAGE: 150 FT.
 WIDTH: 150 FT.
 BLDG. COVERAGE: 20%
 HEIGHT (PRINC.): 35 FT.
 HEIGHT (ACCESS.): 40 FT.
 FRONT YARD: 30 FT.
 CORNER SIDE: 30 FT.
 SIDE YARD: 20 FT.
 REAR YARD: 40 FT.
 ACCESS. BLDG. SIDE: 15 FT.
 ACCESS. BLDG. REAR: 10 FT.
 OWTS TO WETLAND: 150 FT.

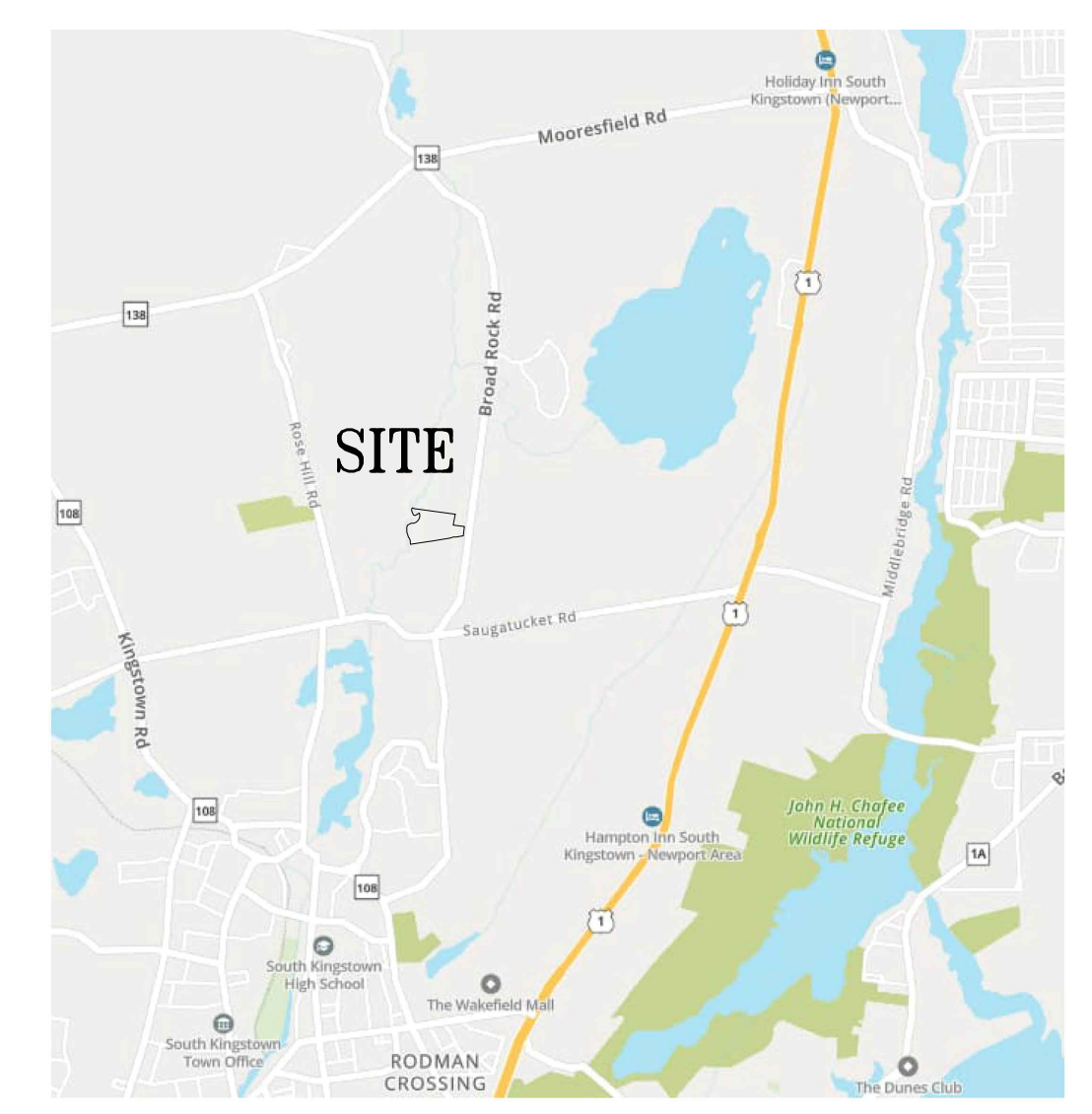

LOCUS MAP
NOT TO SCALE

PROPOSED SUBDIVISION LOT SUMMARY						
LOT	AREA (SQ. FT.)	TOP FOUNDATION (FT.)	GARAGE SLAB (FT.)	BASEMENT SLAB (FT.)	ESHWG ELEV. (FT.)	LOT IMPERVIOUS AREA (SQ. FT.)
1	10,713	85.40	83.90	NONE	80.00	2,800
2	10,347	85.50	82.50	78.00	77.00	2,645
3	12,376	82.50	80.95	75.00	73.00	2,633
4	11,086	78.50	75.75	71.00	69.00	2,677
5	10,583	75.20	73.85	67.70	65.00	2,742
6	10,859	71.50	65.70	64.00	61.00	2,644
7	10,484	73.50	69.70	66.00	64.00	2,737
8	11,174	77.50	75.50	70.00	68.00	2,474
9	16,014	83.50	77.40	76.00	74.00	2,605
10	18,851	80.50	78.40	73.00	71.00	2,617
11	10,158	75.50	73.50	68.00	66.00	2,546
12	14,139	73.50	71.50	66.00	62.00	2,408
13	12,679	70.00	68.80	62.50	59.00	2,448
14	10,082	68.50	67.30	61.00	54.00	2,435
15	12,784	65.50	65.00	58.00	50.00	2,438
16	12,026	71.20	68.70	63.70	61.00	2,425
17	10,306	75.75	73.30	68.25	66.00	2,390
18	10,848	80.00	77.50	72.50	70.50	2,466
19	11,430	82.50	81.25	75.00	73.00	2,386
TOTAL LOTS	226,939	SQ. FT.	5.21	ACRES		48,516
DRIVEWAY/UTILITY EASEMENT	53,689	SQ. FT.	1.23	ACRES		28,005
LAND UNSUITABLE	70,567	SQ. FT.	1.62	ACRES		
STORMWATER POND	33,424	SQ. FT.	0.77	ACRES		
OPEN SPACE	334,230	SQ. FT.	7.65	ACRES		

STONE WALL NOTES:
 EXISTING STONE WALL TO BE RELOCATED = 936± FEET
 PROPOSED FEET OF REPLACEMENT STONE WALL = 991± FEET

OWNER:
 SHELEEN CLARKE
 96 DUCK COVE ROAD
 NORTH KINGSTOWN, RI 02852
APPLICANT:
 NEW ENGLAND PROPERTIES, LLC
 257 WICKFORD CT.
 NORTH KINGSTOWN, RI 02852

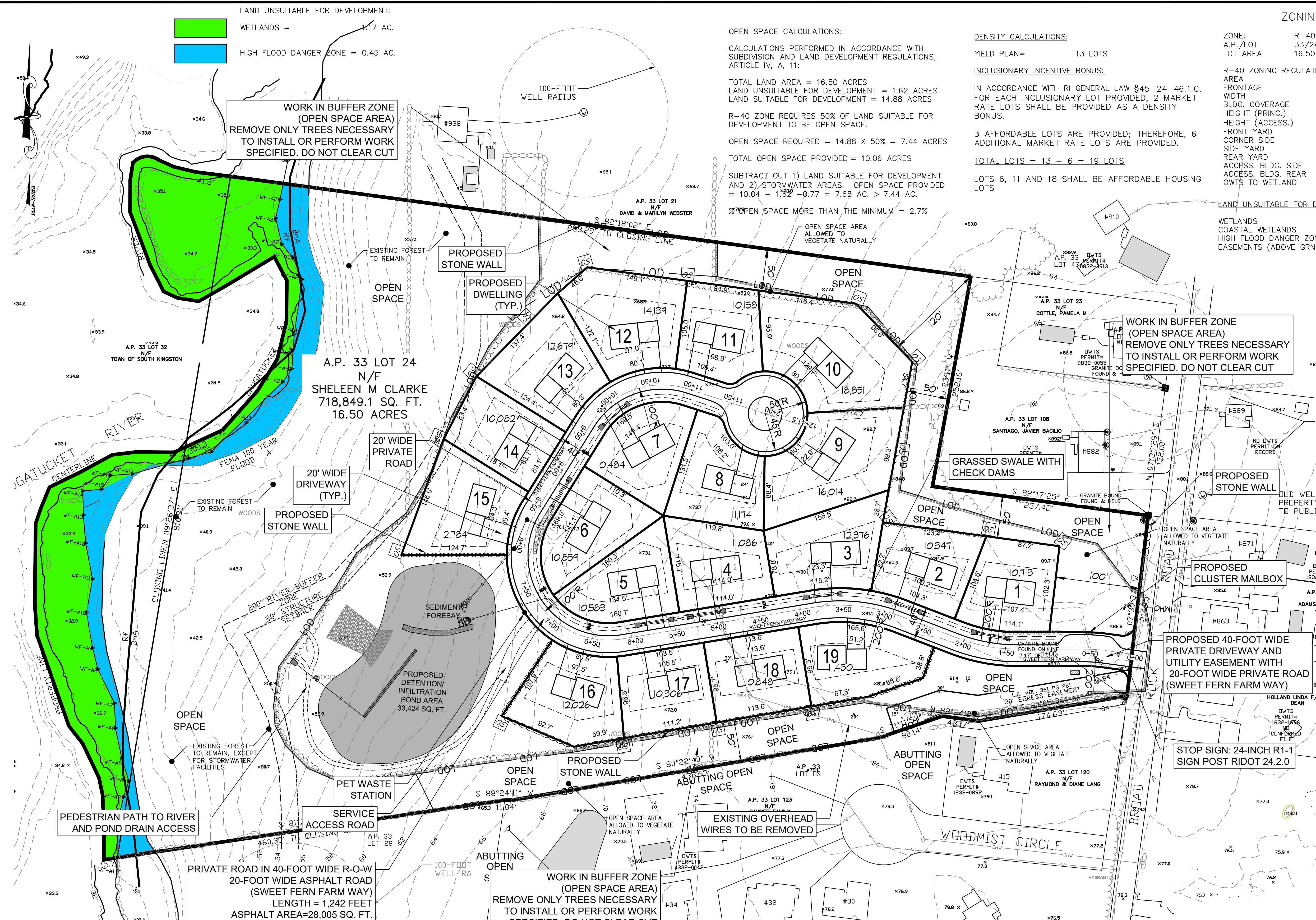

- NOTES:**
- EXISTING PARCEL (A.P. 33 LOT 24) CONSIST OF 16.50± ACRES THAT ARE ZONED R-40.
 - WETLAND FLAGS DELINEATED BY AVIZINIS ENVIRONMENTAL SERVICES, INC. 2022.
 - OFF SITE BUILDING LOCATIONS ARE APPROXIMATE AND HAVE BEEN TAKEN FROM AERIAL PHOTOGRAPHY.
 - ELEVATIONS BASED ON NAVD88 VERTICAL DATUM.
 - A SMALL PORTION OF SUBJECT SITE IS SITUATED IN FEMA 100-YR FLOOD ZONE 'A' AS DEPICTED ON MAP 44009C0201J, EFFECTIVE 4/3/2020. THE REMAINING PORTION OF THE SITE IS SITUATED IN ZONE 'X' WHICH IS AREA OF MINIMAL FLOOD HAZARD.
 - THERE IS NO EXISTING AGRICULTURAL USE ON THE SITE.
 - THE ENTIRE AND SURROUNDING PROPERTIES CONTAIN PRIME AGRICULTURAL SOILS AND FARMLAND SOILS OF IMPORTANCE, PROPERTY.
 - THERE ARE NO EXISTING STREETS, DRIVEWAYS, FARM ROADS, WOODS ROADS AND/OR TRAILS THAT HAVE BEEN IN PUBLIC USE.
 - THERE ARE NO HISTORIC CEMETERIES LOCATED ON OR ADJACENT TO THE SITE.
 - THE SITE IS LOCATED WITHIN A NATURAL HERITAGE AREA AS DEFINED BY RIDEM.
 - THE SITE IS NOT LOCATED WITHIN A DRINKING WATER RESERVOIR, GROUNDWATER RECHARGE AREA OR SOLE SOURCE AQUIFER AS DEFINED BY RIDEM.
 - THE SITE IS NOT LOCATED IN A CRMC SAMP AREA, A TOWN OF SOUTH KINGSTOWN GROUNDWATER PROTECTION OVERLAY DISTRICT OR AN OWTS CRITICAL RESOURCE AREA.
 - THE SITE AND ANY EXISTING BUILDINGS ON THE SITE ARE NOT LISTED ON THE NATIONAL REGISTER OF HISTORIC PLACES.
 - THE SAUGATUCKET RIVER HAS A TMDL FOR FECAL COLIFORM.

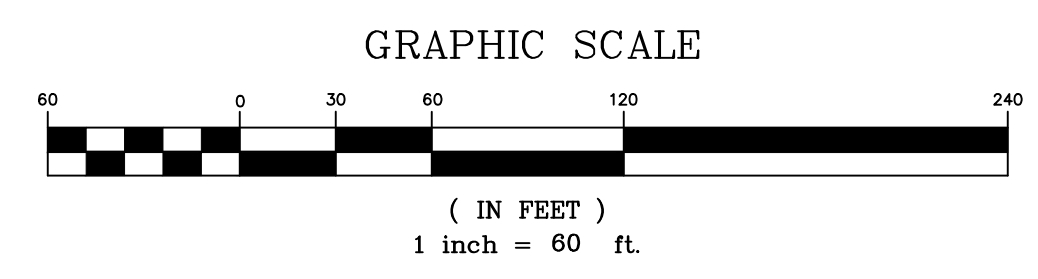

PROPOSED LAYOUT PLAN
SCALE: 1" = 60'

- LEGEND**
- ABUTTER LINE
 - LOT LINE
 - EDGE OF ROAD PAVEMENT
 - ROADWAY CENTERLINE
 - ROADWAY STATION
 - TEST HOLE
 - PERC TEST
 - LEDGE TEST
 - UTILITY POLE
 - WETLAND EDGE
 - 200' RIVER BUFFER ZONE
 - 20' STRUCTURE SETBACK
 - EXISTING STONEMALL
 - UNDERGROUND TELE/COMM
 - OPEN SPACE MARKER
 - BUILDING SETBACK LINE
 - EXISTING CONTOUR
 - EXISTING SPOT GRADE
 - PROPOSED LOT CONTOUR
 - PROPOSED SPOT GRADE
 - DRAINAGE MANHOLE
 - HYDRANT
 - DRAIN LINE
 - WATERLINE
 - OVERHEAD WIRES
 - UNDERGROUND ELECTRIC/TELE
 - SOIL BOUNDARY LINE
 - FEMA 100-YR FLOOD ZONE
 - CURB STOP
 - WATER VALVE
 - PROPOSED STONE WALL

TIMOTHY J. BEHAN
 No. 6278
 REGISTERED PROFESSIONAL ENGINEER
 11/24/2024

COMMONWEALTH ENGINEERS & CONSULTANTS, INC.
 400 SMITH STREET
 PROVIDENCE, RHODE ISLAND 02908
 (401) 273-6600

REVISIONS

No.	DATE	DRWN	CHKD
1	4/2/24	TB	TB
2	4/18/24	TB	TB
3	9/6/24	SMA	TB
4	9/30/24	SMA	TB
5	10/21/24	SMA	TB
6	11/24/24	SMA	TB

PERMIT AGENCY REVIEW PLAN
 FOR
 VILLAGE AT BROAD ROCK
 PLAT 33, LOT 24
 ON
 BROAD ROCK ROAD
 SOUTH KINGSTOWN, RHODE ISLAND
PROPOSED LAYOUT PLAN

SCALE: AS SHOWN SHEET NO: 4 OF 17
 DRAWN BY: SMA DESIGN BY: SMA CHECKED BY: TJB
 DATE: FEBRUARY 2024 PROJECT NO: 23011.00

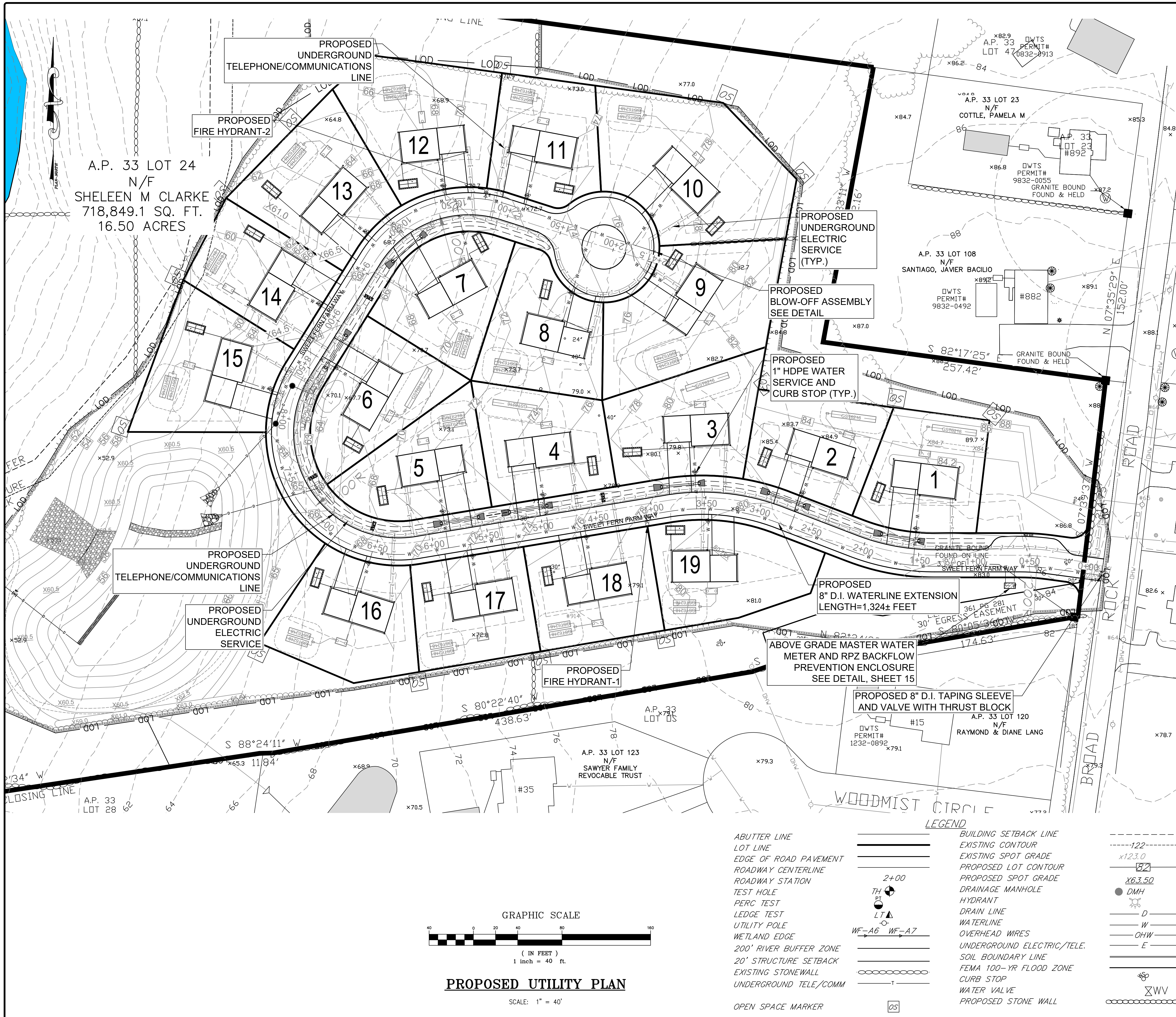

A.P. 33 LOT 24
N/F
SHELEEN M CLARKE
718,849.1 SQ. FT.
16.50 ACRES

- NOTES:**
- EXISTING PARCEL, (A.P. 33 LOT 24) CONSIST OF 16.50±ACRES THAT ARE ZONED R-40.
 - WETLAND FLAGS DELINEATED BY AVIZINIS ENVIRONMENTAL SERVICES, INC. 2022.
 - OFF SITE BUILDING LOCATIONS ARE APPROXIMATE AND HAVE BEEN TAKEN FROM AERIAL PHOTOGRAPHY.
 - ABUTTING PROPERTY OWTS' TAKEN FROM PLANS OF RECORD.
 - ELEVATIONS BASED ON NAVD88 VERTICAL DATUM.
 - A SMALL PORTION OF SUBJECT SITE IS SITUATED IN FEMA 100-YR FLOOD ZONE "A" AS DEPICTED ON MAP 440090201J, EFFECTIVE 4/3/2020. THE REMAINING PORTION OF THE SITE IS SITUATED IN ZONE "X" WHICH IS AREA OF MINIMAL FLOOD HAZARD.
 - THE BmA SOIL TYPE IS CONSIDERED A 'PRIME AGRICULTURAL SOIL'.
 - THIS IS NOT A SURVEY BOUNDARY PLAN, REFER TO SURVEY PLAN AT THE REAR OF THE PLAN SET. SURVEY INFORMATION PROVIDED BY COMMONWEALTH LAND SURVEYORS, INC.

UTILITY CONNECTION SUMMARY

LOT	WATER SERVICE STATION	ELECTRIC SERVICE STATION	TELE/COMM SERVICE STATION
LOT-1	1+54.20	1+19.40	1+21.40
LOT-2	2+68.20	2+38.25	2+40.25
LOT-3	3+58.75	3+32.50	3+34.50
LOT-4	4+94.90	4+65.00	4+67.00
LOT-5	5+86.75	6+18.10	6+16.10
LOT-6	8+62.65	8+88.80	8+86.80
LOT-7	10+53.35	9+56.70	9+54.70
LOT-8	11+76.35	12+01.75	12+03.75
LOT-9	12+13.75	12+34.20	12.32.20
LOT-10	12+15.20	12+30.20	12+28.20
LOT-11	11+12.75	10+86.45	10+84.45
LOT-12	10+45.30	10+67.75	10+69.75
LOT-13	9+77.45	9+98.60	9+96.60
LOT-14	9+03.60	8+72.30	8+74.30
LOT-15	8+19.60	8+39.25	8+37.25
LOT-16	6+51.75	6+34.60	6+36.60
LOT-17	5+66.85	5+36.85	5+38.85
LOT-18	4+62.60	4+32.60	4+34.60
LOT-19	3+47.40	3+51.40	3+53.40
HYDRANT-1	4+06.25	N/A	N/A
HYDRANT-2	10+77.75	N/A	N/A

ESTIMATED PROPOSED DAILY DESIGN WATER/WASTEWATER FLOWS PER RIDEM REGULATIONS

TYPE	DESIGN FLOW	DESIGN UNITS	DESIGN FLOW (GAL/DAY)
BEDROOMS	115 GAL/BEDROOM/DAY	19 UNITS x 4BEDROOMS EACH = 76	8,740
TOTAL ESTIMATED MAXIMUM DAILY DESIGN FLOW (GAL.)			8,740

DESIGN FLOW = MAXIMUM DAILY FLOW (PEAK FLOW)
 AVERAGE DAILY FLOW = DESIGN FLOW / 2.0 (SEE RULE 21)
 HOURLY PEAK FLOW FACTOR IS 5.7 (TR-16, FIGURE 2-1)

PEAK FLOW	8,740 GAL/DAY
AVERAGE DAILY FLOW	4370 GAL/DAY
HOURLY PEAK FLOW	= 4,370 GAL/DAY X 5.7 / 1,440 = 17.3 GAL/MIN.

OWNER:
SHELEEN CLARKE
96 DUCK COVE ROAD
NORTH KINGSTOWN, RI 02852

APPLICANT:
NEW ENGLAND PROPERTIES, LLC
257 WICKFORD CT.
NORTH KINGSTOWN, RI 02852

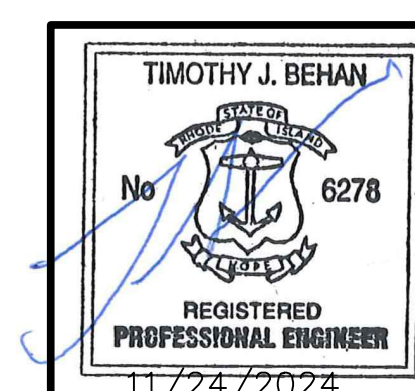

REVISIONS

No.	DATE	DRWN	CHKD
1	4/2/24	TB	TB
2	4/18/24	TB	TB
3	9/6/24	SMA	TB
4	9/30/24	SMA	TB
5	10/21/24	SMA	TB
6	11/24/24	SMA	TB

PERMIT AGENCY REVIEW PLAN
FOR
VILLAGE AT BROAD ROCK
PLAT 33, LOT 24
ON
BROAD ROCK ROAD
SOUTH KINGSTOWN, RHODE ISLAND
PROPOSED UTILITY PLAN

SCALE: AS SHOWN SHEET NO: 6 OF 17
 DRAWN BY: SMA DESIGN BY: SMA CHECKED BY: TJB
 DATE: FEBRUARY 2024 PROJECT NO: 23011.00

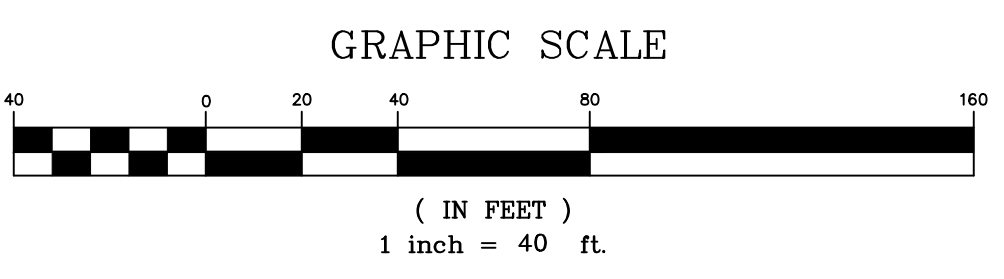

PROPOSED UTILITY PLAN
SCALE: 1" = 40'

- LEGEND**
- ABUTTER LINE
 - LOT LINE
 - EDGE OF ROAD PAVEMENT
 - ROADWAY CENTERLINE
 - ROADWAY STATION
 - TEST HOLE
 - HYDRANT
 - LEDGE TEST
 - UTILITY POLE
 - WETLAND EDGE
 - 200' RIVER BUFFER ZONE
 - 20' STRUCTURE SETBACK
 - EXISTING STONEWALL
 - UNDERGROUND TELE/COMM
 - OPEN SPACE MARKER
 - BUILDING SETBACK LINE
 - EXISTING CONTOUR
 - EXISTING SPOT GRADE
 - PROPOSED LOT CONTOUR
 - PROPOSED SPOT GRADE
 - DRAINAGE MANHOLE
 - HYDRANT
 - DRAIN LINE
 - WATERLINE
 - OVERHEAD WIRES
 - UNDERGROUND ELECTRIC/TELE.
 - SOIL BOUNDARY LINE
 - FEMA 100-YR FLOOD ZONE
 - CURB STOP
 - WATER VALVE
 - PROPOSED STONE WALL

NOTES:

- EXISTING PARCEL (A.P. 33 LOT 24) CONSIST OF 16.50±ACRES THAT ARE ZONED R-40.
- WETLAND FLAGS DELINEATED BY AVIZINIS ENVIRONMENTAL SERVICES, INC. 2022.
- OFF SITE BUILDING LOCATIONS ARE APPROXIMATE AND HAVE BEEN TAKEN FROM AERIAL PHOTOGRAPHY.
- ABUTTING PROPERTY OWTS TAKEN FROM PLANS OF RECORD.
- ELEVATIONS BASED ON NAVD88 VERTICAL DATUM.
- A SMALL PORTION OF SUBJECT SITE IS SITUATED IN FEMA 100-YR FLOOD ZONE 'A' AS DEPICTED ON MAP 44090201J, EFFECTIVE 4/3/2020. THE REMAINING PORTION OF THE SITE IS SITUATED IN ZONE 'X' WHICH IS AREA OF MINIMAL FLOOD HAZARD.
- THE BmA SOIL TYPE IS CONSIDERED A 'PRIME AGRICULTURAL SOIL'. THIS IS NOT A SURVEY BOUNDARY PLAN, REFER TO SURVEY PLAN AT THE REAR OF THE PLAN SET. SURVEY INFORMATION PROVIDED BY COMMONWEALTH LAND SURVEYORS, INC.

LAND UNSUITABLE FOR DEVELOPMENT:

- WETLANDS = 1.17 AC.
- HIGH FLOOD DANGER ZONE = 0.45 AC.

OWTS DESIGN SUMMARY TABLE														
LOT	NUMBER OF BEDROOMS	EXISTING GRADE AT CENTER OF LEACHFIELD	BUILDING SEWER AT FOUNDATION ELEV. (FT.)	SEPTIC TANK INLET ELEV. (FT.)	SEPTIC TANK OUTLET ELEV. (FT.)	INVERT DISTRIBUTION BOX INLET ELEV. (FT.)	INVERT DISTRIBUTION BOX OUTLET ELEV. (FT.)	INVERT DISTRIBUTION LINE ELEV. (FT.)	BOTTOM GST6218 LEACHFIELD ELEV. (FT.)	MIN. LEACHFIELD COVER ELEV. (FT.)	ESHWG ELEV. (FT.)	LEDGE ELEV. (FT.)	SLEEVED BUILDING SEWER (Y/N)	PUMP REQUIRED (Y/N)
LOT-1	4	88.0	82.00	81.87	81.62	85.21	85.04	84.87	83.20	85.70	80.00	78.00	N	Y
LOT-2	4	86.2	80.00	79.87	79.62	84.21	84.04	83.87	82.20	84.70	78.20	76.20	N	Y
LOT-3	4	82.3	80.00	79.87	79.62	79.51	79.34	79.17	77.50	80.00	74.30	72.30	N	Y
LOT-4	4	75.7	73.53	73.40	73.15	72.91	72.74	72.57	70.90	73.40	67.70	65.70	N	N
LOT-5	4	73.2	68.50	68.37	68.12	70.41	70.24	70.07	68.40	70.90	65.20	63.20	N	Y
LOT-6	4	71.4	68.00	67.87	67.62	69.61	69.44	69.27	67.60	70.10	64.40	62.40	N	Y
LOT-7	4	72.7	68.00	67.87	67.62	69.91	69.74	69.57	67.90	70.40	64.70	62.70	N	Y
LOT-8	4	73.7	71.65	71.52	71.27	70.91	70.74	70.57	68.90	71.40	65.70	63.70	N	N
LOT-9	4	82.2	80.53	80.40	80.15	79.41	79.24	79.07	77.40	79.90	74.20	72.20	N	N
LOT-10	4	75.5	75.40	75.28	75.03	72.71	72.54	72.37	70.70	73.20	67.50	65.50	N	N
LOT-11	4	71.7	71.99	71.86	71.61	71.21	71.04	70.87	69.20	71.70	66.00	64.00	N	N
LOT-12	4	67.5	65.45	65.33	65.08	64.71	64.54	64.37	62.70	65.20	59.50	57.50	N	N
LOT-13	4	64.3	62.36	61.99	61.74	61.51	61.34	61.17	59.50	62.00	56.30	54.30	Y	N
LOT-14	4	59.3	58.21	57.83	57.58	57.31	57.14	56.97	55.30	57.80	51.30	49.30	Y	N
LOT-15	4	55.5	57.42	57.06	56.81	56.51	56.34	56.17	54.50	57.00	47.50	45.50	Y	N
LOT-16	4	65.8	65.88	65.52	65.27	64.81	64.64	64.47	62.80	65.30	57.80	55.80	Y	N
LOT-17	4	72.0	71.52	71.16	70.91	70.51	70.34	70.17	68.50	71.00	64.00	62.00	Y	N
LOT-18	4	77.0	77.24	76.86	76.61	76.01	75.84	75.67	74.00	76.50	69.00	67.00	Y	N
LOT-19	4	80.1	79.19	79.07	78.82	78.36	78.19	78.02	76.35	78.85	72.10	70.10	N	N

LEACHFIELD SIZING CALCULATIONS:
 FLOW TO LEACHFIELD = 115 GAL./BEDROOM/DAY X 4 BEDROOMS = 460 GAL./DAY
 LOADING RATE = 0.48 GAL./SQ.FT./DAY (CAT. BM SOILS)
 SQUARE FEET REQ'D. = 460 / 0.48 = 958 S.F.
 USE GST LEACHING SYSTEM GST6218 = 24.8 S.F. PER L.F.
 PROVIDED = 40 L.F. X 24.8 S.F./L.F. = 992 S.F. > 958 S.F., OK

TANK SIZING CALCULATIONS:

SEPTIC TANK
 4-BEDROOM RESIDENTIAL HOUSE
 1,000 GALLON TANK FOR 3-BEDROOMS PLUS 250 GALLONS PER ADDITIONAL BEDROOM
 1,000 GAL. + 250 GAL. = 1,250 MIN. TANK SIZE
 1,500 GAL. 2-COMPARTMENT TANK PROVIDED

OWTS NOTES:

- SEPARATION DISTANCES FROM PUBLIC WELLS, PRIVATE WELLS, PER RULE 6.21 (B) (4) (B & C) HAVE BEEN VERIFIED. WATER COURSES WITHIN 200-FOOT AND EXISTING OWTS WITHIN 100-FOOT HAVE BEEN SHOWN PER RULE 6.21 (B) (4) (A & D).
- ADDITIONAL SOIL EVALUATION TEST RESULTS MAY BE REQUIRED FOR INDIVIDUAL OWTS APPLICATION SUBMITTALS.

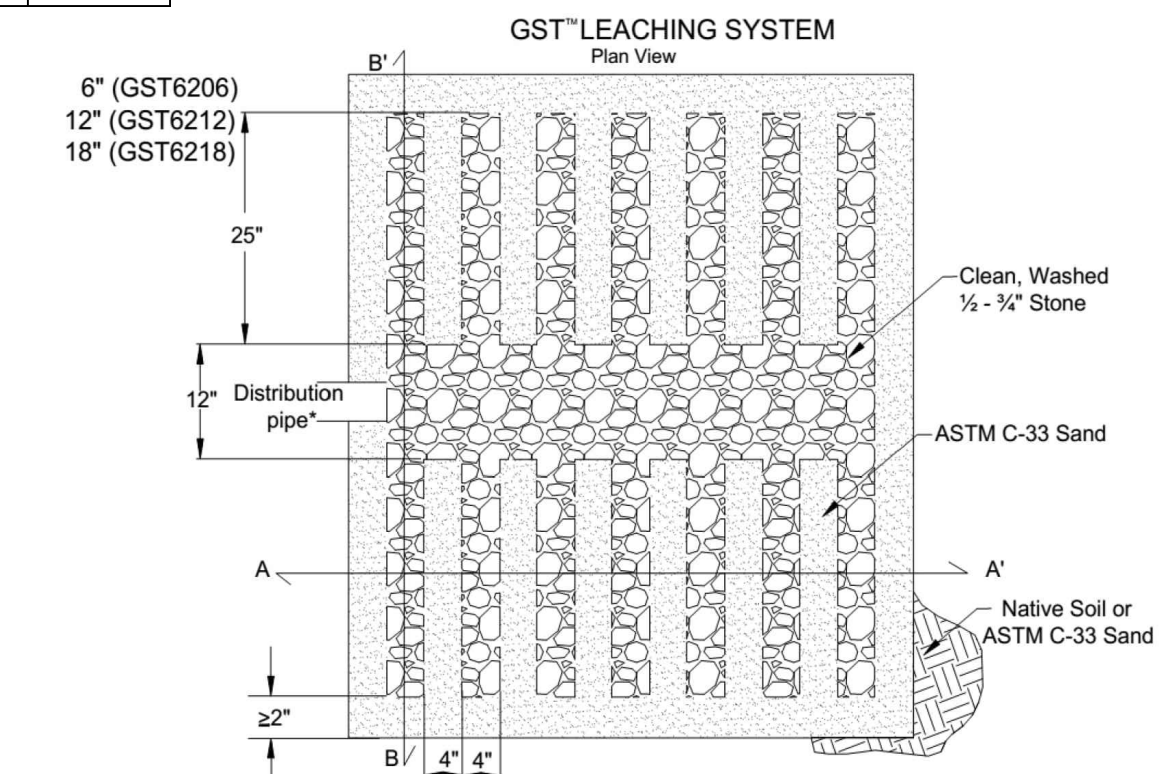

* Distribution pipe for gravity systems shall comply with RIDEM OWTS Rule 6.34C
 Distribution pipe for pressure applications shall comply with RIDEM Guidelines for the Design, Use and Maintenance of Pressurized Drainfields

Figure 4

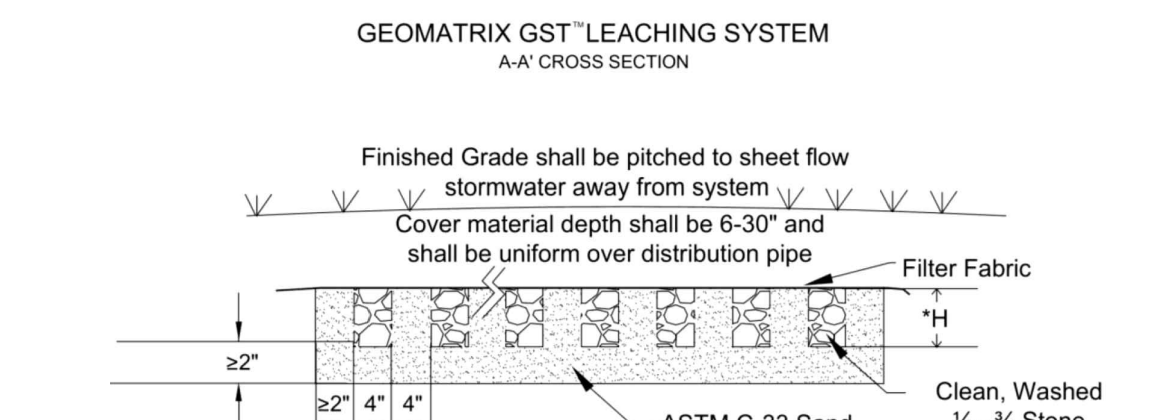

"H" = 6" (GST6206)
 12" (GST6212)
 18" (GST6218)

Figure 5

OWNER:
 SHELEEN CLARKE
 96 DUCK COVE ROAD
 NORTH KINGSTOWN, RI 02852

APPLICANT:
 NEW ENGLAND PROPERTIES, LLC
 257 WICKFORD CT.
 NORTH KINGSTOWN, RI 02852

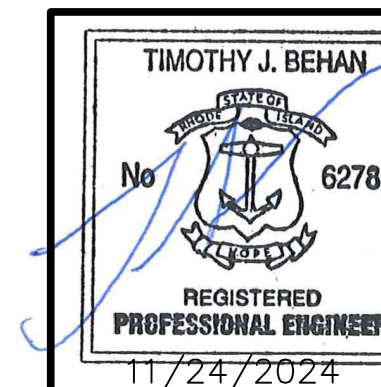

REVISIONS

No.	DATE	DRWN	CHKD
1	4/2/24	TB	TB
2	4/18/24	TB	TB
3	9/6/24	SMA	TB
4	9/30/24	SMA	TB
5	10/21/24	SMA	TB
6	11/24/24	SMA	TB

PERMIT AGENCY REVIEW PLAN
 FOR
 VILLAGE AT BROAD ROCK
 PLAT 33, LOT 24
 ON
 BROAD ROCK ROAD
 SOUTH KINGSTOWN, RHODE ISLAND
PROPOSED OWTS LOCATION PLAN

SCALE: AS SHOWN SHEET NO: 7 OF 17
 DRAWN BY: SMA DESIGN BY: SMA CHECKED BY: TJB
 DATE: FEBRUARY 2024 PROJECT NO: 23011.00

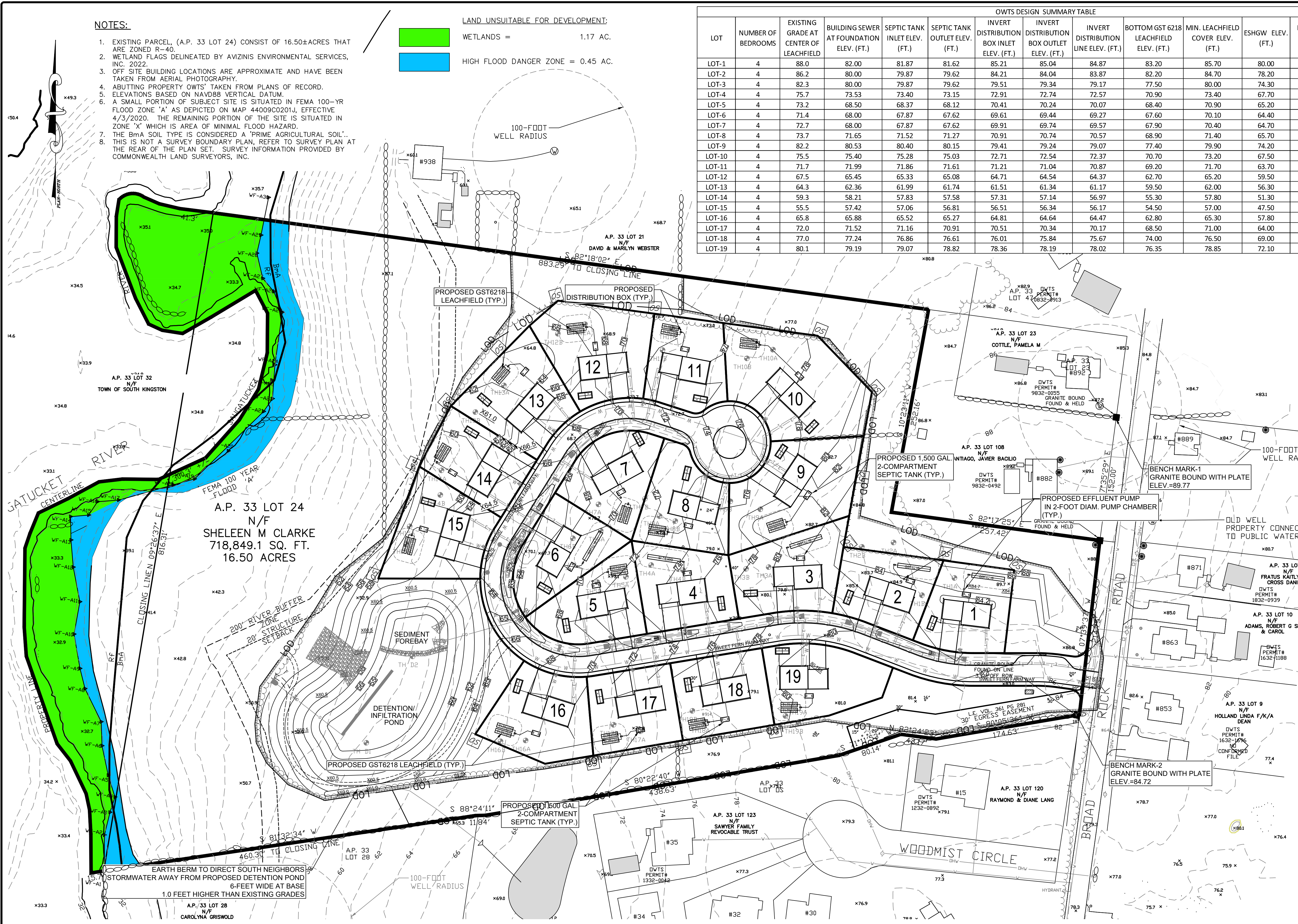

LEGEND

ABUTTER LINE	---	BUILDING SETBACK LINE	---
LOT LINE	---	EXISTING CONTOUR	---
EDGE OF ROAD PAVEMENT	---	EXISTING SPOT GRADE	---
ROADWAY CENTERLINE	---	PROPOSED LOT CONTOUR	---
ROADWAY STATION	---	PROPOSED SPOT GRADE	---
TEST HOLE	TH	DRAINAGE MANHOLE	---
PERC TEST	PT	HYDRANT	---
LEDGE TEST	L7	DRAIN LINE	---
UTILITY POLE	U	WATERLINE	---
WETLAND EDGE	WF-A6, WF-A7	OVERHEAD WIRES	---
200' RIVER BUFFER ZONE	---	UNDERGROUND ELECTRIC/TELE.	---
20' STRUCTURE SETBACK	---	SOIL BOUNDARY LINE	---
EXISTING STONEWALL	---	FEMA 100-YR FLOOD ZONE	---
UNDERGROUND TELE/COMM	---	CURB STOP	---
OPEN SPACE MARKER	OS	WATER VALVE	---
		PROPOSED STONE WALL	---

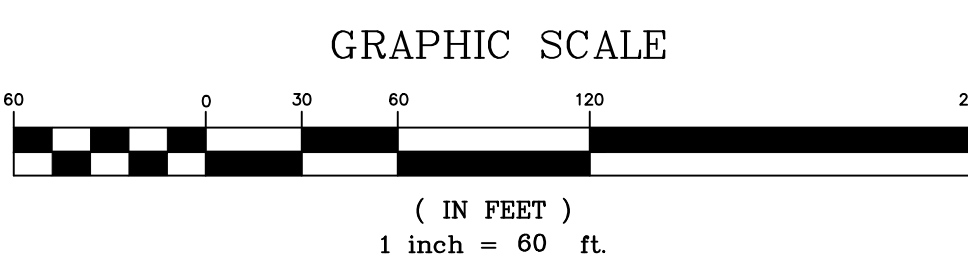

PROPOSED OWTS LOCATION PLAN

SCALE: 1" = 60'

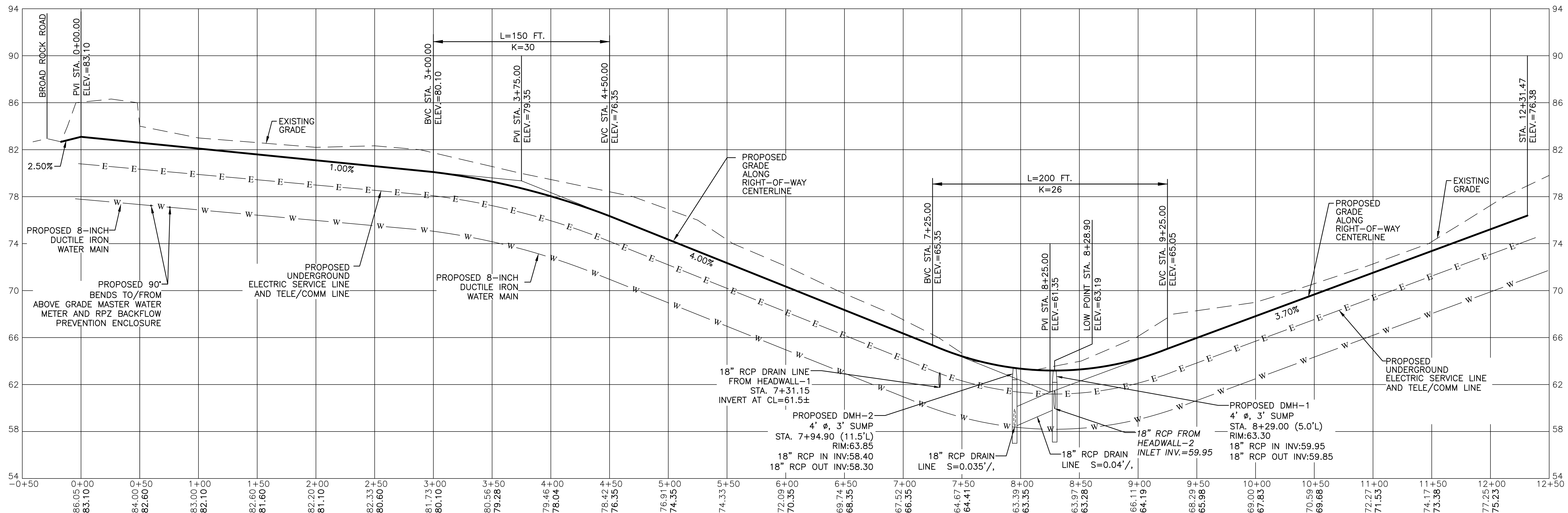

UTILITY CONNECTION SUMMARY			
LOT	WATER SERVICE STATION	ELECTRIC SERVICE STATION	TELE/COMM SERVICE STATION
LOT-1	1+54.20	1+19.40	1+21.40
LOT-2	2+68.20	2+38.25	2+40.25
LOT-3	3+58.75	3+32.50	3+34.50
LOT-4	4+94.90	4+65.00	4+67.00
LOT-5	5+86.75	6+18.10	6+16.10
LOT-6	8+62.65	8+88.80	8+86.80
LOT-7	10+53.35	9+56.70	9+54.70
LOT-8	11+76.35	12+01.75	12+03.75
LOT-9	12+13.75	12+34.20	12.32.20
LOT-10	12+15.20	12+30.20	12+28.20
LOT-11	11+12.75	10+86.45	10+84.45
LOT-12	10+45.30	10+67.75	10+69.75
LOT-13	9+77.45	9+98.60	9+96.60
LOT-14	9+03.60	8+72.30	8+74.30
LOT-15	8+19.60	8+39.25	8+37.25
LOT-16	6+51.75	6+34.60	6+36.60
LOT-17	5+66.85	5+36.85	5+38.85
LOT-18	4+62.60	4+32.60	4+34.60
LOT-19	3+47.40	3+51.40	3+53.40
HYDRANT-1	6+22.30	N/A	N/A
HYDRANT-2	12+38.55	N/A	N/A

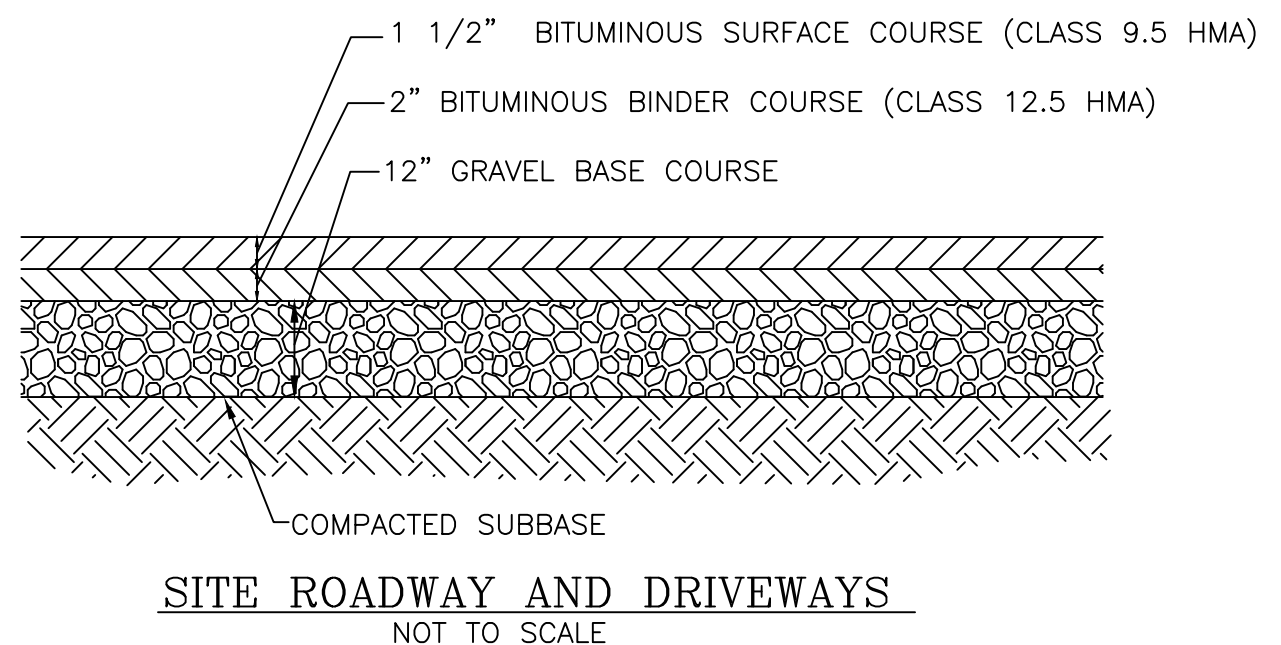

PROFILE VIEW
SCALE
HORIZONTAL: 1-INCH= 40- FEET
VERTICAL: 1-INCH= 4- FEET

OWNER:
SHELEEN CLARKE
96 DUCK COVE ROAD
NORTH KINGSTOWN, RI 02852

APPLICANT:
NEW ENGLAND PROPERTIES, LLC
257 WICKFORD CT.
NORTH KINGSTOWN, RI 02852

- NOTES:**
- EXISTING PARCEL (A.P. 33 LOT 24) CONSIST OF 16.50±ACRES THAT ARE ZONED R-40.
 - WETLAND FLAGS DELINEATED BY AVIZINIS ENVIRONMENTAL SERVICES, INC. 2022.
 - OFF SITE BUILDING LOCATIONS ARE APPROXIMATE AND HAVE BEEN TAKEN FROM AERIAL PHOTOGRAPHY.
 - ABUTTING PROPERTY OWNS' TAKEN FROM PLANS OF RECORD.
 - ELEVATIONS BASED ON NAVD83 VERTICAL DATUM.
 - A SMALL PORTION OF SUBJECT SITE IS SITUATED IN FEMA 100-YR FLOOD ZONE 'A' AS DEPICTED ON MAP 44009C0201J, EFFECTIVE 4/3/2020. THE REMAINING PORTION OF THE SITE IS SITUATED IN ZONE 'X' WHICH IS AREA OF MINIMAL FLOOD HAZARD.
 - THE BmA SOIL TYPE IS CONSIDERED A 'PRIME AGRICULTURAL SOIL'.. THIS IS NOT A SURVEY BOUNDARY PLAN, REFER TO SURVEY PLAN AT THE REAR OF THE PLAN SET. SURVEY INFORMATION PROVIDED BY COMMONWEALTH LAND SURVEYORS, INC.

LEGEND

ABUTTER LINE	=====	BUILDING SETBACK LINE	-----122-----
LOT LINE	=====	EXISTING CONTOUR	x123.0
EDGE OF ROAD PAVEMENT	=====	EXISTING SPOT GRADE	☒
ROADWAY CENTERLINE	=====	PROPOSED LOT CONTOUR	x63.50
ROADWAY STATION	2+00	PROPOSED SPOT GRADE	☒
TEST HOLE	TH	DRAINAGE MANHOLE	● DMH
PERC TEST	LT	HYDRANT	⊗
LEDGE TEST	LT	DRAIN LINE	— D —
UTILITY POLE	WF-A6 WF-A7	WATERLINE	— W —
WETLAND EDGE	=====	OVERHEAD WIRES	— OHW —
200' RIVER BUFFER ZONE	=====	UNDERGROUND ELECTRIC/TELE.	— E —
20' STRUCTURE SETBACK	=====	SOIL BOUNDARY LINE	=====
EXISTING STONEWALL	=====	FEMA 100-YR FLOOD ZONE	=====
UNDERGROUND TELE/COMM	=====	CURB STOP	⊗
		WATER VALVE	⊗
		PROPOSED STONE WALL	=====
OPEN SPACE MARKER	⊗		

TIMOTHY J. BEHAN
REGISTERED PROFESSIONAL ENGINEER
11/24/2024

REVISIONS			
No.	DATE	DRWN	CHKD
1	4/2/24	TB	TB
2	4/18/24	TB	TB
3	9/6/24	SMA	TB
4	9/30/24	SMA	TB
5	10/21/24	SMA	TB
6	11/24/24	SMA	TB

COMMONWEALTH ENGINEERS & CONSULTANTS, INC.
400 SMITH STREET
PROVIDENCE, RHODE ISLAND 02908
(401) 273-6600

PERMIT AGENCY REVIEW PLAN
FOR
VILLAGE AT BROAD ROCK
PLAT 33, LOT 24
ON
BROAD ROCK ROAD
SOUTH KINGSTOWN, RHODE ISLAND
PROPOSED ROADWAY PROFILE PLAN

SCALE: AS SHOWN	SHEET NO: 8 OF 17	
DRAWN BY: SMA	DESIGN BY: SMA	CHECKED BY: TJB
DATE: FEBRUARY 2024	PROJECT NO: 23011.00	

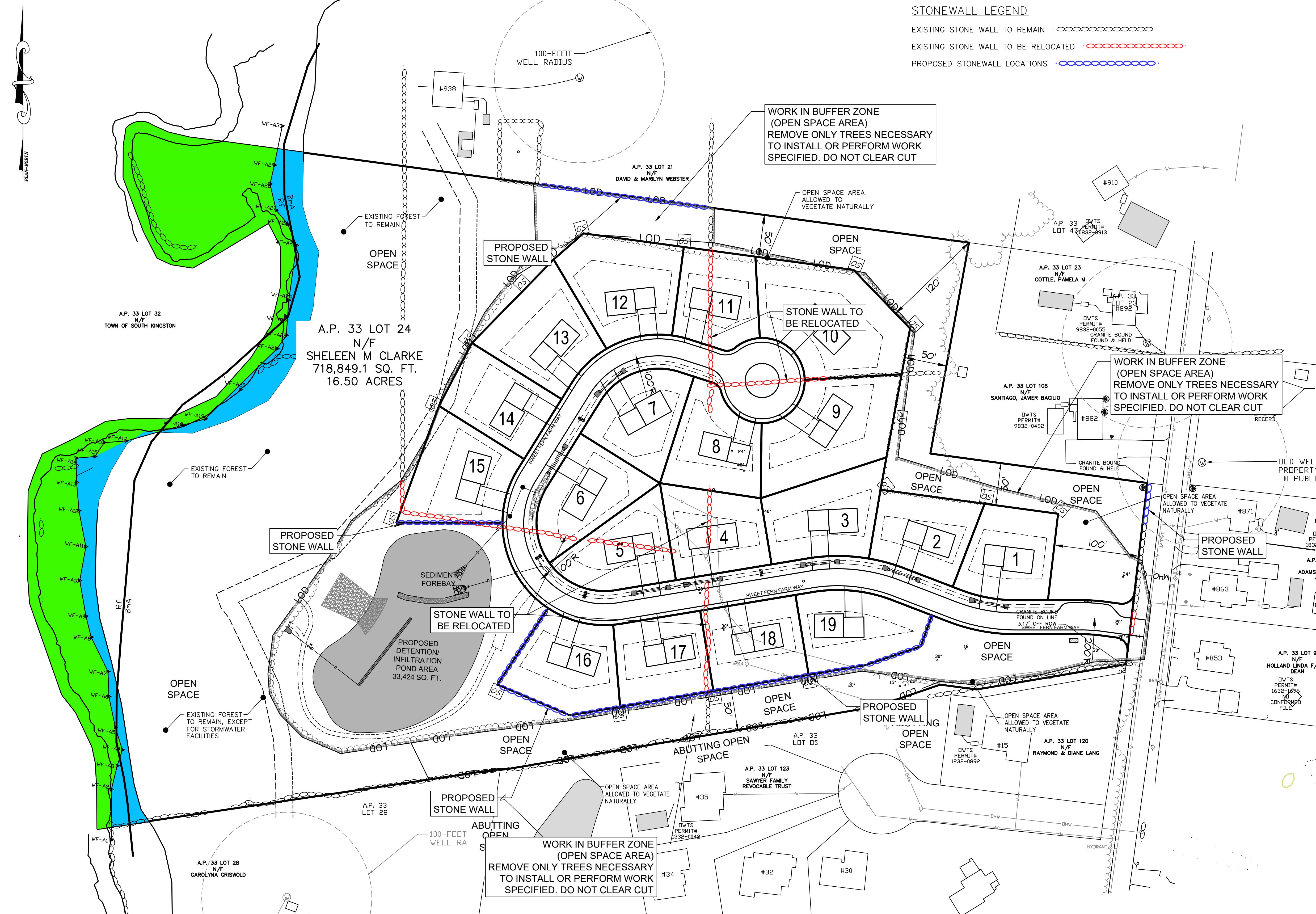

- NOTES:**
- EXISTING PARCEL (A.P. 33 LOT 24) CONSIST OF 16.50±ACRES THAT ARE ZONED R-40.
 - WETLAND FLAGS DELINEATED BY AVIZINIS ENVIRONMENTAL SERVICES, INC. 2022.
 - OFF SITE BUILDING LOCATIONS ARE APPROXIMATE AND HAVE BEEN TAKEN FROM AERIAL PHOTOGRAPHY.
 - ELEVATIONS BASED ON NAVD88 VERTICAL DATUM.
 - A SMALL PORTION OF SUBJECT SITE IS SITUATED IN FEMA 100-YR FLOOD ZONE 'A' AS DEPICTED ON MAP 44009C0201J, EFFECTIVE 4/3/2020. THE REMAINING PORTION OF THE SITE IS SITUATED IN ZONE 'X' WHICH IS AREA OF MINIMAL FLOOD HAZARD.
 - THERE IS NO EXISTING AGRICULTURAL USE ON THE SITE.
 - THE ENTIRE AND SURROUNDING PROPERTIES CONTAIN PRIME AGRICULTURAL SOILS AND FARMLAND SOILS OF IMPORTANCE, PROPERTY.
 - THERE ARE NO EXISTING STREETS, DRIVEWAYS, FARM ROADS, WOODS ROADS AND/OR TRAILS THAT HAVE BEEN IN PUBLIC USE.
 - THERE ARE NO HISTORIC CEMETERIES LOCATED ON OR ADJACENT TO THE SITE.
 - THE SITE IS LOCATED WITHIN A NATURAL HERITAGE AREA AS DEFINED BY RIDEM.
 - THE SITE IS NOT LOCATED WITHIN A DRINKING WATER RESERVOIR, GROUNDWATER RECHARGE AREA OR SOLE SOURCE AQUIFER AS DEFINED BY RIDEM.
 - THE SITE IS NOT LOCATED IN A CRMC SAMP AREA, A TOWN OF SOUTH KINGSTOWN GROUNDWATER PROTECTION OVERLAY DISTRICT OR AN OWTS CRITICAL RESOURCE AREA.
 - THE SITE AND ANY EXISTING BUILDINGS ON THE SITE ARE NOT LISTED ON THE NATIONAL REGISTER OF HISTORIC PLACES.
 - THE SAUGATUCKET RIVER HAS A TMDL FOR FECAL COLIFORM.

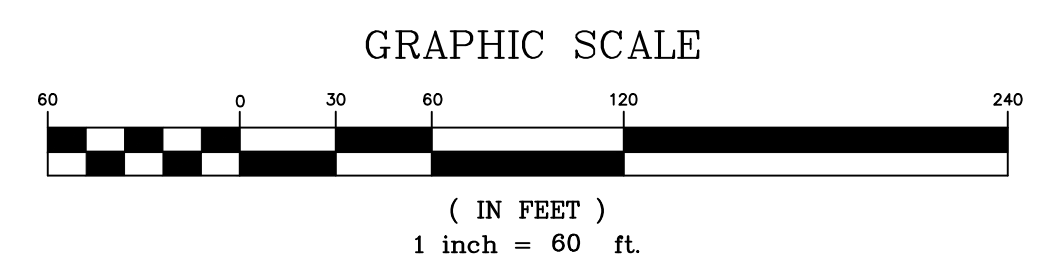

PROPOSED STONEWALL PLAN
SCALE: 1" = 60'

STONEWALL LEGEND

- EXISTING STONE WALL TO REMAIN
- EXISTING STONE WALL TO BE RELOCATED
- PROPOSED STONEWALL LOCATIONS

WORK IN BUFFER ZONE (OPEN SPACE AREA) REMOVE ONLY TREES NECESSARY TO INSTALL OR PERFORM WORK SPECIFIED. DO NOT CLEAR CUT

WORK IN BUFFER ZONE (OPEN SPACE AREA) REMOVE ONLY TREES NECESSARY TO INSTALL OR PERFORM WORK SPECIFIED. DO NOT CLEAR CUT

WORK IN BUFFER ZONE (OPEN SPACE AREA) REMOVE ONLY TREES NECESSARY TO INSTALL OR PERFORM WORK SPECIFIED. DO NOT CLEAR CUT

LEGEND

- ABUTTER LINE
- LOT LINE
- EDGE OF ROAD PAVEMENT
- ROADWAY CENTERLINE
- ROADWAY STATION
- TEST HOLE
- PERC TEST
- LEDGE TEST
- UTILITY POLE
- WETLAND EDGE
- 200' RIVER BUFFER ZONE
- 20' STRUCTURE SETBACK
- EXISTING STONEWALL
- UNDERGROUND TELE/COMM
- OPEN SPACE MARKER
- BUILDING SETBACK LINE
- EXISTING CONTOUR
- EXISTING SPOT GRADE
- PROPOSED LOT CONTOUR
- PROPOSED SPOT GRADE
- DRAINAGE MANHOLE
- HYDRANT
- DRAIN LINE
- WATERLINE
- OVERHEAD WIRES
- UNDERGROUND ELECTRIC/TELE.
- SOIL BOUNDARY LINE
- FEMA 100-YR FLOOD ZONE
- CURB STOP
- WATER VALVE
- PROPOSED STONE WALL

STONE WALL NOTES:

- EXISTING STONEWALL VARY FROM RUBBLE PILES TO 2-FOOT WIDE AND 2-FOOT TALL
- EXISTING STONE WALL TO BE RELOCATED = 936± FEET
936 FT. X 3 FT. X 2 FT.=5,616 CF.
5,616 CF. / 27 (CF./CY.)=208 CUBIC YARDS
- PROPOSED FEET OF REPLACEMENT STONE WALL= 991± FEET
991 FT. X 3 FT. X 2 FT.= 5,946 CF.
5,946 CF. / 27 (CF./CY.)=220 CUBIC YARDS
- ALL EXISTING STONE SHALL BE REUSED ON SITE. STONE REMOVED DURING SITE CONSTRUCTION WILL BE REUSED ON SITE. ADDITIONAL STONE WILL BE IMPORTED AS NEEDED.
- PROPOSED STONEWALLS HEIGHTS SHALL BE CONSTRUCTED TO MATCH THE HEIGHT OF EXISTING WALLS IN THE IMMEDIATE AREA.
- STONE QUANTITIES ASSUME 1.0 FT OF STONE BELOW GRADE AND AN AVERAGE 2.0 FT. ABOVE FINISH GRADE

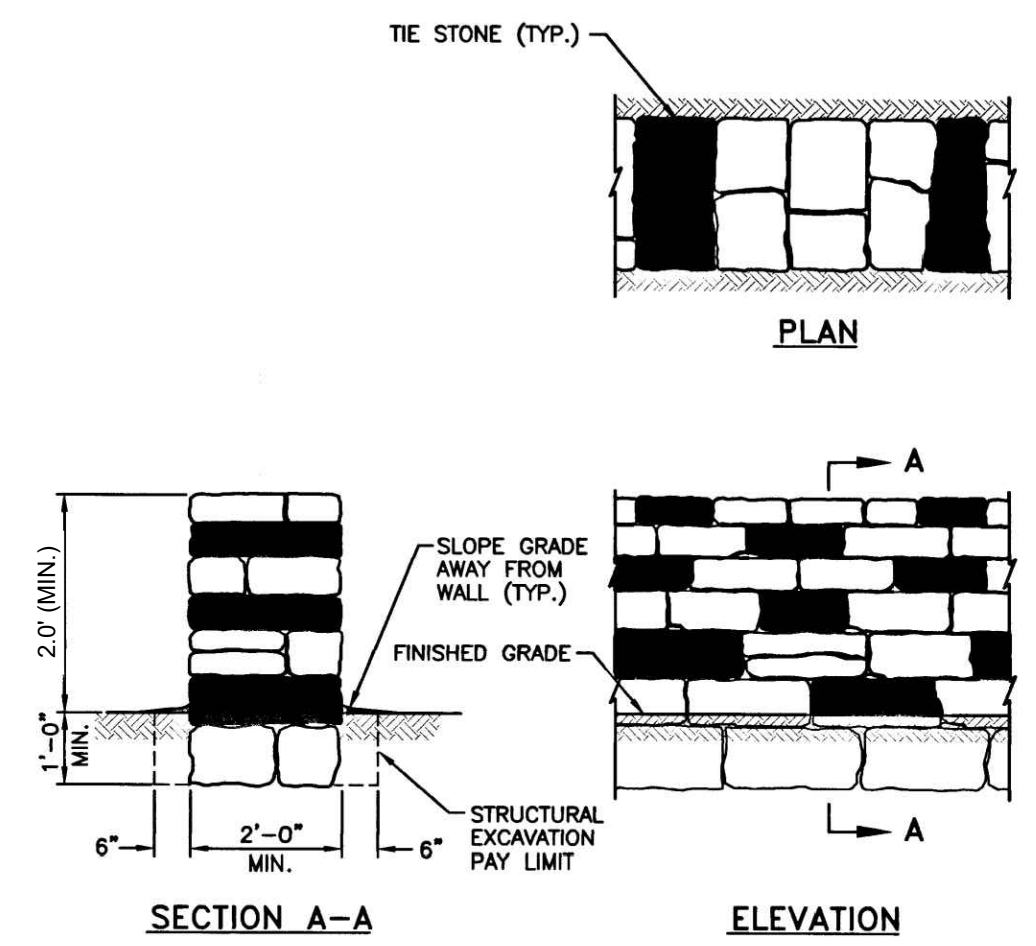

STONEWALL CONSTRUCTION DETAIL
NOT TO SCALE

OWNER:
SHELEEN CLARKE
96 DUCK COVE ROAD
NORTH KINGSTOWN, RI 02852

APPLICANT:
NEW ENGLAND PROPERTIES, LLC
257 WICKFORD CT.
NORTH KINGSTOWN, RI 02852

TIMOTHY J. BEHAN
No. 6278
REGISTERED PROFESSIONAL ENGINEER
11/24/2024

COMMONWEALTH ENGINEERS & CONSULTANTS, INC.
400 SMITH STREET
PROVIDENCE, RHODE ISLAND 02908
(401) 273-6600

REVISIONS

No.	DATE	DRWN	CHKD
1	4/2/24	TB	TB
2	4/18/24	TB	TB
3	9/6/24	SMA	TB
4	9/30/24	SMA	TB
5	10/21/24	SMA	TB
6	11/24/24	SMA	TB

PERMIT AGENCY REVIEW PLAN
FOR
VILLAGE AT BROAD ROCK
PLAT 33, LOT 24
ON
BROAD ROCK ROAD
SOUTH KINGSTOWN, RHODE ISLAND
PROPOSED STONEWALL PLAN

SCALE: AS SHOWN	SHEET NO: 9 OF 17
DRAWN BY: SMA	DESIGN BY: SMA
DATE: FEBRUARY 2024	CHECKED BY: TJB
	PROJECT NO 23011.00

SEDIMENT TRAP DESIGN CALCULATIONS

TRAP #	TOTAL DEPTH (FT)	TRAP WATERSHED AREA (ACRES)	STORAGE VOLUME REQUIRED (CF)	1" OVER WATERSHED (CF)	WET STORAGE VOLUME (Vw) (CF)	Dw (FT)	Aw (SF)	Aw PROVIDED (SF)	DRY STORAGE VOLUME (Vd) (CF)	Dd (FT)	Ad (SF)	Ad PROVIDED (SF)
1	3	2.26	8,170	8,198	4,099	1.5	3,215	7,210	4099	1.5	9,082	9,205
2	3	1.59	5,756	5,775	2,887	1.5	2,265	4,785	2887	1.5	6,583	6,696
3A & 3B	3	1.64	5,922	5,942	2,971	1.5	2,300	5,144	2971	2.5	6,583	7,318
4A & 4B	3	1.53	5,532	5,551	2,775	1.5	2,177	5,144	2775	1.5	6,149	7,318
5	3	2.91	10,544	10,579	5,290	1.5	4,149	9,374	5290	1.5	11,720	12,084

Dw = THE MAXIMUM DEPTH FROM BOTTOM OF TRAP TO THE BASE OF THE STONE OUTLET
 Dd = THE DEPTH FROM THE BASE OF THE STONE OUTLET TO THE TOP OF THE STONE OUTLET
 Aw = THE SURFACE AREA OF THE FLOODED AREA AT THE BASE OF THE STONE OUTLET
 Ad = THE SURFACE AREA OF THE FLOODED AREA AT THE TOP OF THE STONE OUTLET
 STORAGE VOLUME REQUIRED = 134 CUBIC YARDS PER ACRE OR 1" OVER WATER SHED AREA, WHICH EVER IS GREATER

$Vw = 0.85 * Aw * Dw$
 $Vd = ((Aw + Ad) / 2) * Dd$

LAND UNSUITABLE FOR DEVELOPMENT:
 WETLANDS = 1.17 AC.
 HIGH FLOOD DANGER ZONE = 0.45 AC.

- NOTES:
- EXISTING PARCEL (A.P. 33 LOT 24) CONSIST OF 16.50±ACRES THAT ARE ZONED R-40.
 - WETLAND FLAGS DELINEATED BY AVIZINIS ENVIRONMENTAL SERVICES, INC. 2022.
 - OFF SITE BUILDING LOCATIONS ARE APPROXIMATE AND HAVE BEEN TAKEN FROM AERIAL PHOTOGRAPHY.
 - ABUTTING PROPERTY OWNS "TAKEN FROM PLANS OF RECORD.
 - ELEVATIONS BASED ON NAVD88 VERTICAL DATUM.
 - A SMALL PORTION OF SUBJECT SITE IS SITUATED IN FEMA 100-YR FLOOD ZONE "A" AS DEPICTED ON MAP 44009C0201J, EFFECTIVE 4/3/2020. THE REMAINING PORTION OF THE SITE IS SITUATED IN ZONE "X" WHICH IS AREA OF MINIMAL FLOOD HAZARD.
 - THE Bm_a SOIL TYPE IS CONSIDERED A "PRIME AGRICULTURAL SOIL".
 - THIS IS NOT A SURVEY BOUNDARY PLAN, REFER TO SURVEY PLAN AT THE REAR OF THE PLAN SET. SURVEY INFORMATION PROVIDED BY COMMONWEALTH LAND SURVEYORS, INC.

OWNER:
 SHELEEN CLARKE
 96 DUCK COVE ROAD
 NORTH KINGSTOWN, RI 02852

APPLICANT:
 NEW ENGLAND PROPERTIES, LLC
 257 WICKFORD CT.
 NORTH KINGSTOWN, RI 02852

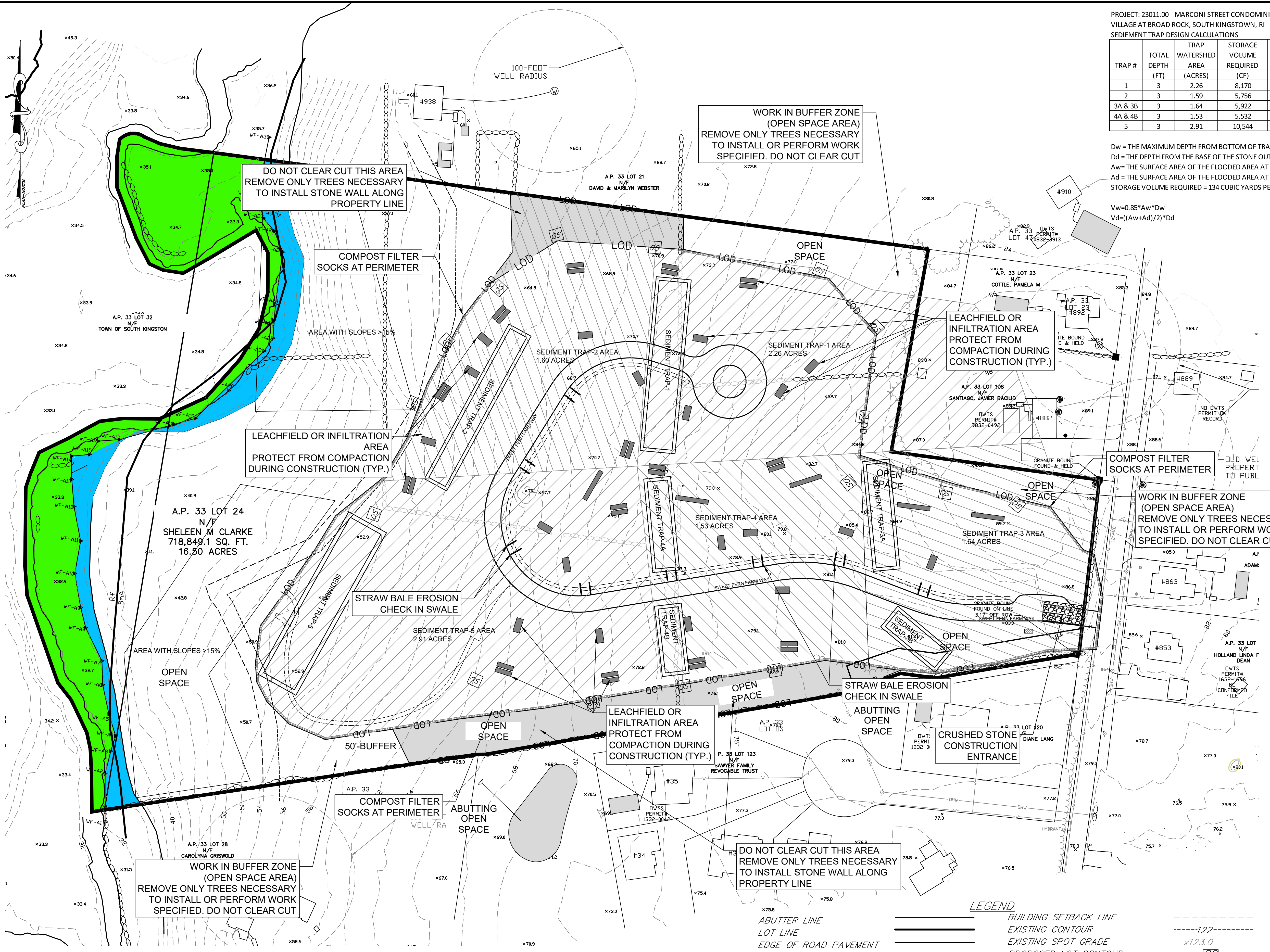

- SESC NOTES:
- CONTRACTOR TO DETERMINE SOIL STOCK PILE AREAS.
 - CONTRACTOR TO DETERMINE CONCRETE WASHOUT AREAS.
 - EXISTING TOPSOIL (LOAM) SHALL BE REUSED ON SITE TO THE EXTENT PRACTICAL.
 - INSTALL ADDITIONAL COMPOST FILTER SOCKS ON SITE AS NEEDED AND AS SHOWN IN THE DETAIL ON SHEET 10.

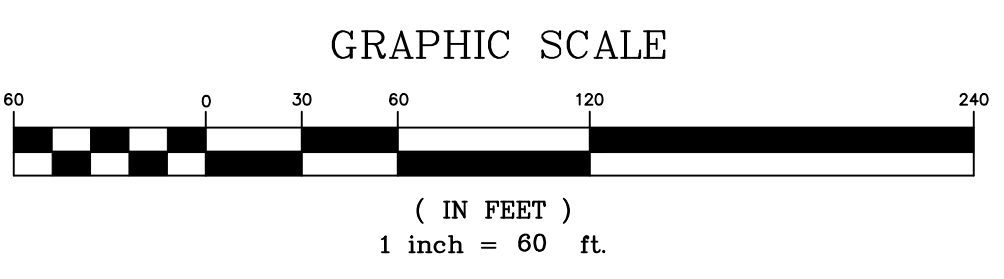

SOIL EROSION AND SEDIMENT CONTROL PLAN

LEGEND

---	BUILDING SETBACK LINE	---	UNDERGROUND ELECTRIC/TELE.
---	EXISTING CONTOUR	---	SOIL BOUNDARY LINE
---	EXISTING SPOT GRADE	---	FEMA 100-YR FLOOD ZONE
---	PROPOSED LOT CONTOUR	---	CURB STOP
---	PROPOSED SPOT GRADE	---	WATER VALVE
---	DRAINAGE DRAINAGE MANHOLE	---	PROPOSED STONE WALL
---	HYDRANT	---	
---	DRAIN LINE	---	
---	WATERLINE	---	
---	OVERHEAD WIRES	---	
---	WETLAND EDGE	---	
---	200' RIVER BUFFER ZONE	---	
---	20' STRUCTURE SETBACK	---	
---	EXISTING STONEMALL	---	
---	UNDERGROUND TELE/COMM	---	
---	ABUTTER LINE	---	
---	LOT LINE	---	
---	EDGE OF ROAD PAVEMENT	---	
---	ROADWAY CENTERLINE	---	
---	ROADWAY STATION	---	
---	TEST HOLE	---	
---	PERC TEST	---	
---	LEDGE TEST	---	
---	UTILITY POLE	---	
---	WETLAND EDGE	---	
---	200' RIVER BUFFER ZONE	---	
---	20' STRUCTURE SETBACK	---	
---	EXISTING STONEMALL	---	
---	UNDERGROUND TELE/COMM	---	
---	ABUTTER LINE	---	
---	LOT LINE	---	
---	EDGE OF ROAD PAVEMENT	---	
---	ROADWAY CENTERLINE	---	
---	ROADWAY STATION	---	
---	TEST HOLE	---	
---	PERC TEST	---	
---	LEDGE TEST	---	
---	UTILITY POLE	---	
---	WETLAND EDGE	---	
---	200' RIVER BUFFER ZONE	---	
---	20' STRUCTURE SETBACK	---	
---	EXISTING STONEMALL	---	
---	UNDERGROUND TELE/COMM	---	
---	ABUTTER LINE	---	
---	LOT LINE	---	
---	EDGE OF ROAD PAVEMENT	---	
---	ROADWAY CENTERLINE	---	
---	ROADWAY STATION	---	
---	TEST HOLE	---	
---	PERC TEST	---	
---	LEDGE TEST	---	
---	UTILITY POLE	---	
---	WETLAND EDGE	---	
---	200' RIVER BUFFER ZONE	---	
---	20' STRUCTURE SETBACK	---	
---	EXISTING STONEMALL	---	
---	UNDERGROUND TELE/COMM	---	
---	ABUTTER LINE	---	
---	LOT LINE	---	
---	EDGE OF ROAD PAVEMENT	---	
---	ROADWAY CENTERLINE	---	
---	ROADWAY STATION	---	
---	TEST HOLE	---	
---	PERC TEST	---	
---	LEDGE TEST	---	
---	UTILITY POLE	---	
---	WETLAND EDGE	---	
---	200' RIVER BUFFER ZONE	---	
---	20' STRUCTURE SETBACK	---	
---	EXISTING STONEMALL	---	
---	UNDERGROUND TELE/COMM	---	
---	ABUTTER LINE	---	
---	LOT LINE	---	
---	EDGE OF ROAD PAVEMENT	---	
---	ROADWAY CENTERLINE	---	
---	ROADWAY STATION	---	
---	TEST HOLE	---	
---	PERC TEST	---	
---	LEDGE TEST	---	
---	UTILITY POLE	---	
---	WETLAND EDGE	---	
---	200' RIVER BUFFER ZONE	---	
---	20' STRUCTURE SETBACK	---	
---	EXISTING STONEMALL	---	
---	UNDERGROUND TELE/COMM	---	
---	ABUTTER LINE	---	
---	LOT LINE	---	
---	EDGE OF ROAD PAVEMENT	---	
---	ROADWAY CENTERLINE	---	
---	ROADWAY STATION	---	
---	TEST HOLE	---	
---	PERC TEST	---	
---	LEDGE TEST	---	
---	UTILITY POLE	---	
---	WETLAND EDGE	---	
---	200' RIVER BUFFER ZONE	---	
---	20' STRUCTURE SETBACK	---	
---	EXISTING STONEMALL	---	
---	UNDERGROUND TELE/COMM	---	
---	ABUTTER LINE	---	
---	LOT LINE	---	
---	EDGE OF ROAD PAVEMENT	---	
---	ROADWAY CENTERLINE	---	
---	ROADWAY STATION	---	
---	TEST HOLE	---	
---	PERC TEST	---	
---	LEDGE TEST	---	
---	UTILITY POLE	---	
---	WETLAND EDGE	---	
---	200' RIVER BUFFER ZONE	---	
---	20' STRUCTURE SETBACK	---	
---	EXISTING STONEMALL	---	
---	UNDERGROUND TELE/COMM	---	
---	ABUTTER LINE	---	
---	LOT LINE	---	
---	EDGE OF ROAD PAVEMENT	---	
---	ROADWAY CENTERLINE	---	
---	ROADWAY STATION	---	
---	TEST HOLE	---	
---	PERC TEST	---	
---	LEDGE TEST	---	
---	UTILITY POLE	---	
---	WETLAND EDGE	---	
---	200' RIVER BUFFER ZONE	---	
---	20' STRUCTURE SETBACK	---	
---	EXISTING STONEMALL	---	
---	UNDERGROUND TELE/COMM	---	
---	ABUTTER LINE	---	
---	LOT LINE	---	
---	EDGE OF ROAD PAVEMENT	---	
---	ROADWAY CENTERLINE	---	
---	ROADWAY STATION	---	
---	TEST HOLE	---	
---	PERC TEST	---	
---	LEDGE TEST	---	
---	UTILITY POLE	---	
---	WETLAND EDGE	---	
---	200' RIVER BUFFER ZONE	---	
---	20' STRUCTURE SETBACK	---	
---	EXISTING STONEMALL	---	
---	UNDERGROUND TELE/COMM	---	
---	ABUTTER LINE	---	
---	LOT LINE	---	
---	EDGE OF ROAD PAVEMENT	---	
---	ROADWAY CENTERLINE	---	
---	ROADWAY STATION	---	
---	TEST HOLE	---	
---	PERC TEST	---	
---	LEDGE TEST	---	
---	UTILITY POLE	---	
---	WETLAND EDGE	---	
---	200' RIVER BUFFER ZONE	---	
---	20' STRUCTURE SETBACK	---	
---	EXISTING STONEMALL	---	
---	UNDERGROUND TELE/COMM	---	
---	ABUTTER LINE	---	
---	LOT LINE	---	
---	EDGE OF ROAD PAVEMENT	---	
---	ROADWAY CENTERLINE	---	
---	ROADWAY STATION	---	
---	TEST HOLE	---	
---	PERC TEST	---	
---	LEDGE TEST	---	
---	UTILITY POLE	---	
---	WETLAND EDGE	---	
---	200' RIVER BUFFER ZONE	---	
---	20' STRUCTURE SETBACK	---	
---	EXISTING STONEMALL	---	
---	UNDERGROUND TELE/COMM	---	
---	ABUTTER LINE	---	
---	LOT LINE	---	
---	EDGE OF ROAD PAVEMENT	---	
---	ROADWAY CENTERLINE	---	
---	ROADWAY STATION	---	
---	TEST HOLE	---	
---	PERC TEST	---	
---	LEDGE TEST	---	
---	UTILITY POLE	---	
---	WETLAND EDGE	---	
---	200' RIVER BUFFER ZONE	---	
---	20' STRUCTURE SETBACK	---	
---	EXISTING STONEMALL	---	
---	UNDERGROUND TELE/COMM	---	
---	ABUTTER LINE	---	
---	LOT LINE	---	
---	EDGE OF ROAD PAVEMENT	---	
---	ROADWAY CENTERLINE	---	
---	ROADWAY STATION	---	
---	TEST HOLE	---	
---	PERC TEST	---	
---	LEDGE TEST	---	
---	UTILITY POLE	---	
---	WETLAND EDGE	---	
---	200' RIVER BUFFER ZONE	---	
---	20' STRUCTURE SETBACK	---	
---	EXISTING STONEMALL	---	
---	UNDERGROUND TELE/COMM	---	
---	ABUTTER LINE	---	
---	LOT LINE	---	
---	EDGE OF ROAD PAVEMENT	---	
---	ROADWAY CENTERLINE	---	
---	ROADWAY STATION	---	
---	TEST HOLE	---	
---	PERC TEST	---	
---	LEDGE TEST	---	
---	UTILITY POLE	---	
---	WETLAND EDGE	---	
---	200' RIVER BUFFER ZONE	---	
---	20' STRUCTURE SETBACK	---	
---	EXISTING STONEMALL	---	
---	UNDERGROUND TELE/COMM	---	
---	ABUTTER LINE	---	
---	LOT LINE	---	
---	EDGE OF ROAD PAVEMENT	---	
---	ROADWAY CENTERLINE	---	
---	ROADWAY STATION	---	
---	TEST HOLE	---	
---	PERC TEST	---	
---	LEDGE TEST	---	
---	UTILITY POLE	---	
---	WETLAND EDGE	---	
---	200' RIVER BUFFER ZONE	---	
---	20' STRUCTURE SETBACK	---	
---	EXISTING STONEMALL	---	
---	UNDERGROUND TELE/COMM	---	
---	ABUTTER LINE	---	
---	LOT LINE	---	
---	EDGE OF ROAD PAVEMENT	---	
---	ROADWAY CENTERLINE	---	
---	ROADWAY STATION	---	
---	TEST HOLE	---	
---	PERC TEST	---	
---	LEDGE TEST	---	
---	UTILITY POLE	---	
---	WETLAND EDGE	---	
---	200' RIVER BUFFER ZONE	---	
---	20' STRUCTURE SETBACK	---	
---	EXISTING STONEMALL	---	
---	UNDERGROUND TELE/COMM	---	
---	ABUTTER LINE	---	
---	LOT LINE	---	
---	EDGE OF ROAD PAVEMENT	---	
---	ROADWAY CENTERLINE	---	
---	ROADWAY STATION	---	
---	TEST HOLE	---	
---	PERC TEST	---	
---	LEDGE TEST	---	
---	UTILITY POLE	---	
---	WETLAND EDGE	---	
---	200' RIVER BUFFER ZONE	---	
---	20' STRUCTURE SETBACK	---	
---	EXISTING STONEMALL	---	
---	UNDERGROUND TELE/COMM	---	
---	ABUTTER LINE	---	
---	LOT LINE	---	
---	EDGE OF ROAD PAVEMENT	---	
---	ROADWAY CENTERLINE	---	
---	ROADWAY STATION	---	
---	TEST HOLE	---	
---	PERC TEST	---	
---	LEDGE TEST	---	
---	UTILITY POLE	---	
---	WETLAND EDGE	---	
---	200' RIVER BUFFER ZONE	---	
---	20' STRUCTURE SETBACK	---	
---	EXISTING STONEMALL	---	
---	UNDERGROUND TELE/COMM	---	
---	ABUTTER LINE	---	
---	LOT LINE	---	
---	EDGE OF ROAD PAVEMENT	---	
---	ROADWAY CENTERLINE	---	
---	ROADWAY STATION	---	
---	TEST HOLE	---	
---	PERC TEST	---	
---	LEDGE TEST	---	
---	UTILITY POLE	---	
---	WETLAND EDGE	---	
---	200' RIVER BUFFER ZONE	---	
---	20' STRUCTURE SETBACK	---	
---	EXISTING STONEMALL	---	
---	UNDERGROUND TELE/COMM	---	
---	ABUTTER LINE	---	
---	LOT LINE	---	
---	EDGE OF ROAD PAVEMENT	---	
---	ROADWAY CENTERLINE	---	
---	ROADWAY STATION	---	
---	TEST HOLE	---	
---	PERC TEST	---	
---	LEDGE TEST	---	
---	UTILITY POLE	---	
---	WETLAND EDGE	---	
---	200' RIVER BUFFER ZONE	---	

SEDIMENT TRAP DETAILS

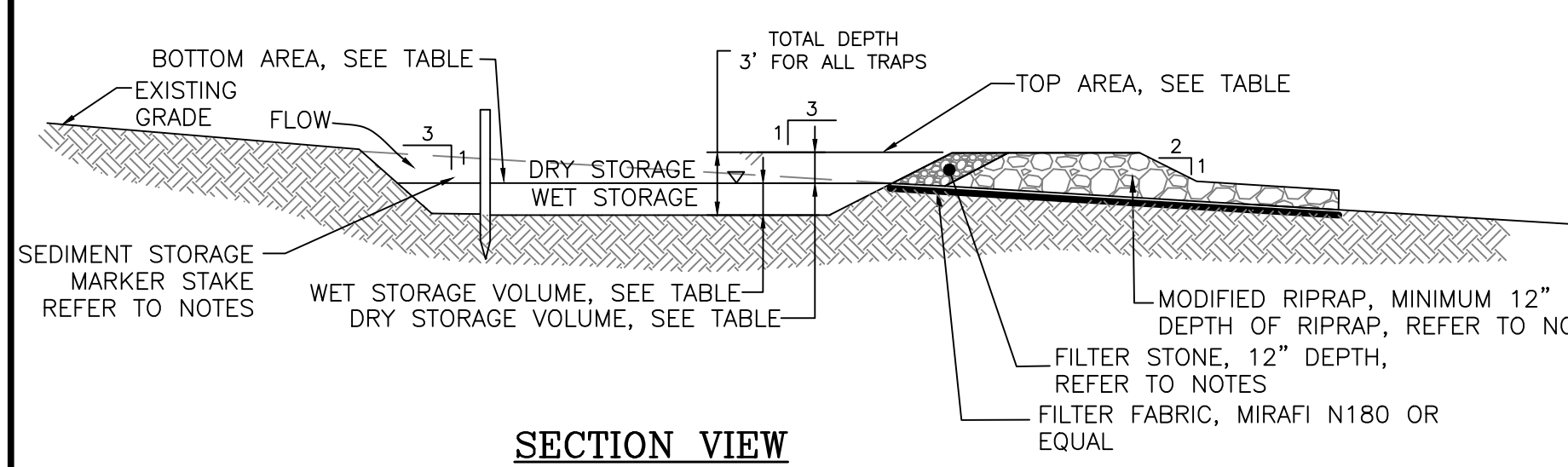

SECTION VIEW

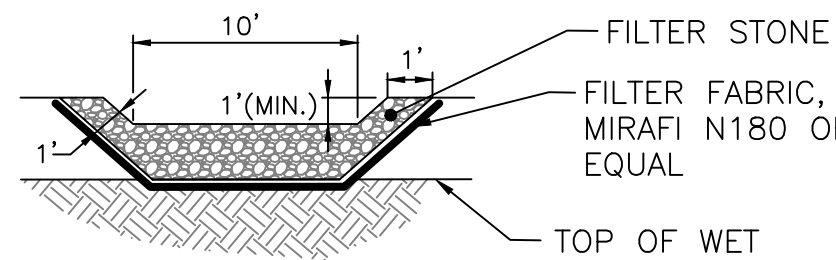

OVERFLOW WEIR SECTION

GENERAL NOTES:

1. THE TEMPORARY SEDIMENT TRAP SHALL MEET ALL REQUIREMENTS FOR TEMPORARY SEDIMENT TRAPS OUTLINED IN THE RHODE ISLAND SOIL EROSION AND SEDIMENT CONTROL HANDBOOK (LATEST REVISION) SECTION SIX: SEDIMENT CONTROL MEASURES.
2. THE TEMPORARY SEDIMENT TRAP SHALL HAVE AN INITIAL STORAGE VOLUME OF 134 CUBIC YARDS PER ACRE OF DRAINAGE AREA.
3. ALL CUT AND FILL SLOPES SHALL BE 2:1 OR FLATTER.
4. THE OUTLET SHALL BE LOCATED AT THE MOST DISTANT HYDRAULIC POINT FROM THE INLET.
5. THE OUTLET CONSISTS OF A PERVIOUS STAKE DIKE WITH A CORE OF MODIFIED RIP RAP AND FACED ON THE UPSTREAM SIDE WITH STONE.
6. TEMPORARY SEDIMENT TRAPS MUST OUTLET ONTO STABILIZED GROUND.
7. MAXIMUM HEIGHT OF A TEMPORARY SEDIMENT TRAP EMBANKMENT IS LIMITED TO FIVE FEET.
8. SIDE SLOPES OF THE EMBANKMENT SHALL BE 2:1 OR FLATTER.
9. MODIFIED RIP RAP SHALL MEET THE REQUIREMENTS OF RIDOT STANDARD SPECIFICATIONS FOR ROAD AND BRIDGE CONSTRUCTION SUBSECTION M.10.03.2 AND BE R-4 GRADE RIPRAP.
10. FILTER STONE SHALL MEET THE REQUIREMENTS OF RIDOT STANDARD SPECIFICATIONS FOR ROAD AND BRIDGE CONSTRUCTION SUBSECTION M.01.03 TABLE 1 COLUMN V FILTER STONE.

INSTALLATION NOTES:

1. CLEAR GRUB AND STRIP ANY VEGETATION AND ROOT MAT FROM ANY PROPOSED EMBANKMENT AND OUTLET AREA.
2. REMOVE STONES AND ROCKS WHOSE DIAMETER IS GREATER THAN 3 INCHES AND OTHER DEBRIS.
3. EXCAVATE WET STORAGE AND CONSTRUCT THE EMBANKMENT AND/OR OUTLET AS NEEDED TO ATTAIN THE NECESSARY STORAGE REQUIREMENTS.
4. USE ONLY FILL MATERIAL FOR THE EMBANKMENT THAT IS FREE FROM EXCESSIVE ORGANICS, DEBRIS, LARGE ROCKS (OVER SIX INCHES) OR OTHER UNSUITABLE MATERIALS. COMPACT THE EMBANKMENT IN 9 INCH LAYERS BY TRAVERSING WITH EQUIPMENT WHILE IT IS BEING CONSTRUCTED.
5. STABILIZE THE EARTHEN EMBANKMENT USING ANY OF THE FOLLOWING MEASURES: SEEDING FOR TEMPORARY VEGETATION COVER, SEEDING FOR PERMANENT VEGETATIVE COVER, OR SLOPE PROTECTION, IMMEDIATELY AFTER INSTALLATION.

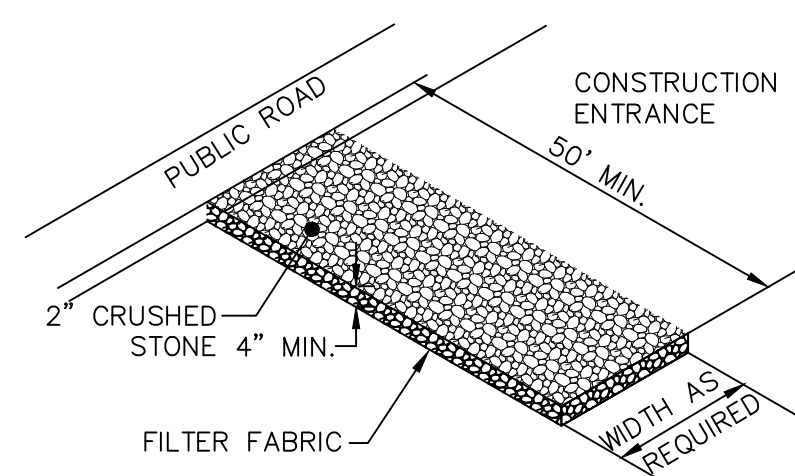

MATERIALS SIZE

SQUARE MESH SIEVES	2" CRUSHED STONE OR GRAVEL	ASTM C-33 NO. 2	ASTM C-33 NO. 3
2-1/2 INCHES	100	90-100	100
2 INCHES	95-100	35-70	90-100
1-1/2 INCHES	30-55	0-15	35-70
1-1/4 INCHES	0-25	-	-
1 INCH	0-5	-	0-15
3/4 INCH	-	0-5	-
1/2 INCH	-	-	0-5
3/8 INCH	-	-	-

NOTE:
STABILIZATION PAD TO BE IN CONFORMANCE WITH STANDARDS SET FORTH IN THE "RHODE ISLAND GUIDELINES FOR SOIL & SEDIMENT CONTROL."

RIP-RAP STABILIZATION PAD @ CONSTRUCTION ENTRANCE

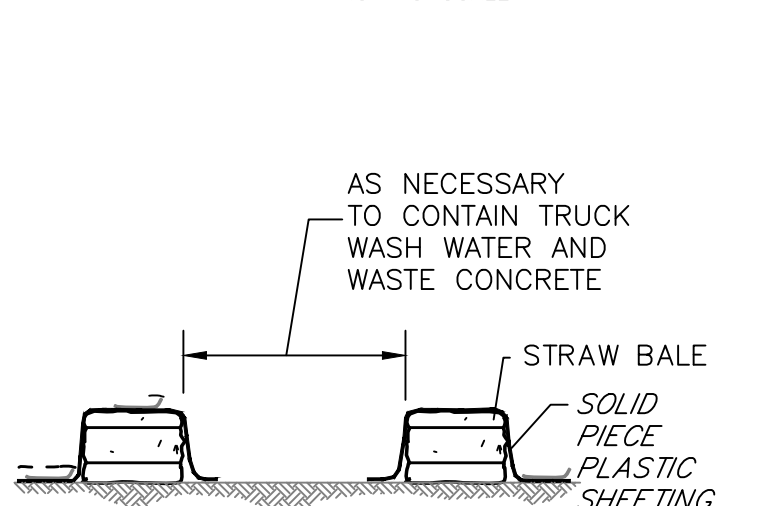

CONCRETE WASHOUT

SEDIMENTATION CONTROL PROGRAM:

1. EXTREME CARE SHALL BE EXERCISED SO AS TO PREVENT ANY UNSUITABLE MATERIAL FROM ENTERING DOWNSTREAM WATERCOURSES AND STORMWATER DRAINAGE SYSTEMS.
2. DURING CONSTRUCTION, THE CONTRACTOR AND/OR DEVELOPER SHALL BE RESPONSIBLE FOR MAINTAINING DRAINAGE AND RUN-OFF FLOW DURING STORMS.
3. SEDIMENTATION CONTROL DEVICES SHALL BE INSPECTED CLOSELY AND MAINTAINED PROMPTLY AFTER EACH RAINFALL.
4. CARE SHALL BE TAKEN SO AS NOT TO PLACE "REMOVED SEDIMENTS" WITHIN THE PATH OF EXISTING, NEWLY CREATED (BOTH TEMPORARY AND PERMANENT) OR PROPOSED WATERCOURSES OR THOSE AREAS SUBJECTED TO STORMWATER FLOWAGE.
5. ADDITIONAL STRAW BALES OR SANDBAGS SHALL BE LOCATED AS CONDITIONS WARRANT OR AS DIRECTED BY THE ENGINEER.
6. EROSION AND SEDIMENTATION CONTROLS SHALL BE INSTALLED AT THE SITE PRIOR TO THE START OF CONSTRUCTION AND BE PROPERLY MAINTAINED UNTIL ALL DISTURBED AREAS ARE STABILIZED INCLUDING:
7. ALL DISTURBED AREAS ARE TO BE PERMANENTLY STABILIZED WITH APPROVED GROUND COVER PRIOR TO THE COMPLETION OF THE PROJECT. AREAS EXPOSED FOR EXTENDED PERIODS ARE TO BE COMPLETELY COVERED WITH SPREAD STRAW MULCH.
8. ALL CONTROL MEASURES WILL BE MAINTAINED IN EFFECTIVE CONDITION THROUGHOUT THE CONSTRUCTION PERIOD.
9. THE LIMITS OF ALL CLEARING, GRADING AND DISTURBANCE SHALL BE KEPT TO A MINIMUM WITHIN THE PROPOSED AREA OF CONSTRUCTION. ALL AREAS OUTSIDE OF THE LIMITS OF DISTURBANCE SHALL REMAIN TOTALLY UNDISTURBED.
10. INSPECT TEMPORARY DIVERSIONS AND THEIR COMPONENTS ONCE A WEEK AND AFTER EVERY RAINFALL. DAMAGE CAUSED BY CONSTRUCTION TRAFFIC OR OTHER ACTIVITY SHOULD BE REPAIRED BEFORE THE END OF EACH WORKING DAY.

POLLUTION PREVENTION NOTES:

1. REFERENCE IS MADE TO APPENDIX G "POLLUTION PREVENTION AND SOURCE CONTROLS" OF THE RHODE ISLAND STORMWATER DESIGN AND INSTALLATION STANDARDS MANUAL, DECEMBER 2010 AS AMENDED. THIS DOCUMENT SHALL BE REFERENCED WHEN IMPLEMENTING THE POLLUTION PREVENTION TECHNIQUES. A BRIEF SUMMARY OF THE TECHNIQUES IS PROVIDED BELOW, REFER TO THE ABOVE REFERENCE FOR ALL TECHNIQUES TO BE IMPLEMENTED.
2. **SOLID WASTE CONTAINMENT:**
 - A. OWNER TO PROVIDE TRASH CONTAINER. CONTAINER TO HAVE A COVER TO PREVENT TRASH FROM BLOWING OUT.
 - B. SWEEP STREET/PARKING AREA ANNUALLY.
 - C. HAZARDOUS MATERIALS CONTAINMENT:
 - A. CONTRACTOR TO STORE ALL HAZARDOUS MATERIALS INSIDE STORAGE LOCKERS OR OTHER APPROVED METHODS WHICH HAVE SECONDARY CONTAINMENT SYSTEMS.
 - B. SECONDARY CONTAINMENT MUST BE INCLUDED WHEREVER SPILLS MIGHT OCCUR (E.G. FUELING AND HAZARDOUS MATERIAL TRANSFER AND LOADING AREAS).
3. **ROADS AND PARKING AREA MANAGEMENT:**
 - A. SWEEP STREET/PARKING AREA ANNUALLY.
 - B. USE DEICING CHEMICALS AND SAND JUDICIOUSLY SINCE THEY CAUSE WATER QUALITY PROBLEMS. PROVIDE AND SPREAD IN ACCORDANCE WITH APPENDIX G RECOMMENDATIONS.
 - C. PLOW SNOW AND STORE ACCUMULATED SNOW PILES AWAY FROM CATCH BASINS INLETS.
 - * DEBRIS SHOULD BE CLEANED FROM THE SITE PRIOR USING THE SITE FOR SNOW DISPOSAL.
 - * DEBRIS SHOULD BE CLEANED FROM THE SITE AND PROPERLY DISPOSED OF AT THE END OF THE SNOW SEASON.
 - D. ONLY USE ASPHALT BASED SEALANTS WHEN SEALING THE PAVEMENTS. DO NOT USE COAL-TAR BASED SEALANTS SINCE THESE ARE MORE TOXIC.
4. **SEPTIC SYSTEM:**
 - A. NO SEPTIC SYSTEMS PROPOSED.
5. **LAWN, GARDEN, AND LANDSCAPE MANAGEMENT:**
 - A. **LAWN CONVERSION** - REDUCE THE AMOUNT OF LAWN BY REPLANTING LAWN WITH GARDEN BEDS CONTAINING FLOWERS/SHRUBS. LAWNS REQUIRE MORE MAINTENANCE THAN FLOWER BEDS.
 - B. **SOIL BUILDING** - MAINTAIN A HEALTHY LAWN BY TESTING SOIL FOR pH, FERTILITY, COMPACTION, TEXTURE, AND EARTH WORM CONTENT.
 - C. **GRASS SELECTION** - SELECT DROUGHT TOLERANT GRASS SPECIES. REFER TO APPENDIX G FOR ADDITIONAL INFORMATION.
 - D. **MOWING AND THATCH MANAGEMENT** - KEEP GRASS HEIGHT HIGH SUCH AS 2 TO 3 INCHES IN HEIGHT. THIS WILL REDUCE WEED GROWTH.
 - E. **FERTILIZATION** - MINIMIZE FERTILIZATION. FERTILIZE NO MORE THAN TWICE A YEAR. APPLY CAREFULLY SO FERTILIZER DOES NOT SPREAD ONTO IMPERVIOUS SURFACES. REFER TO APPENDIX G FOR ADDITIONAL INFORMATION.
 - F. **WEED MANAGEMENT** - NEVER USE CHEMICAL HERBICIDES TO ELIMINATE OR CONTROL WEEDS. OWNER SHALL REMOVE WEEDS BY PULLING OR DIGGING OUT. REFER TO APPENDIX G FOR ADDITIONAL INFORMATION.
 - G. **PEST MANAGEMENT** - LIMIT PESTICIDE USE. CHOOSE PESTICIDES THAT POSE THE LEAST RISK TO HUMAN HEALTH AND THE ENVIRONMENT. REFER TO APPENDIX G FOR ADDITIONAL INFORMATION.
 - H. **SENSIBLE IRRIGATION** - WATER NO MORE THAN 1" PER WEEK. USE DROUGHT-RESISTANT GRASSES. CUT GRASS AT 2-3 INCHES.

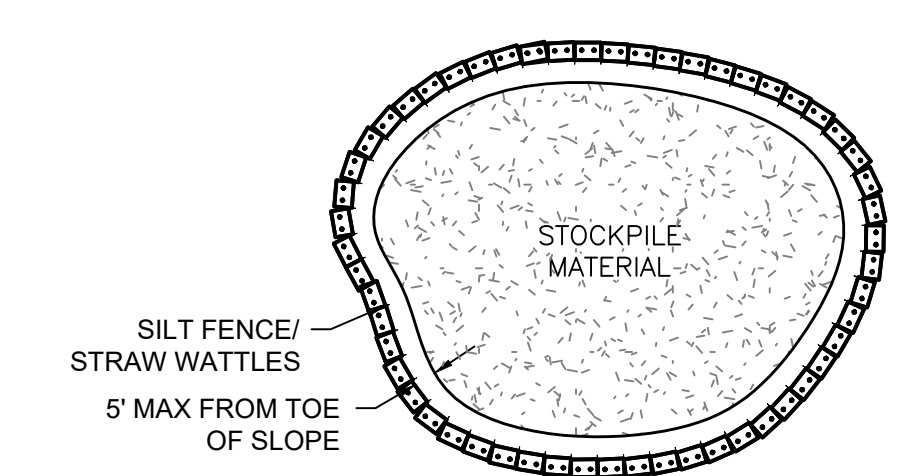

MATERIAL STOCKPILE DETAIL

STOCKPILE NOTES:

1. COVERINGS MUST BE SECURED AND INSPECTED DAILY AND REPAIRED/REPLACED AS NEEDED.
2. WORKING ENTRANCE TO STOCKPILE SHALL BE ON THE UP-GRADE SIDE OF THE STOCK PILE.
3. PERIMETER EROSION CONTROLS SHALL BE INSPECTED DAILY AND REPAIRED/REPLACED AS NEEDED.
4. CONTRACTOR TO DETERMINE STOCKPILE LOCATIONS.

STORMWATER INFILTRATION PRACTICES

1. STORMWATER INFILTRATION MEASURES ARE HEAVILY RELIANT ON THE INFILTRATION CAPACITY OF THE UNDERLYING IN-SITU SOILS FOR THEIR PROPER FUNCTION AND LONGEVITY. OVER-COMPACTING OF UNDERLYING SOILS WILL COMPROMISE THE EFFECTIVENESS OF SUCH PRACTICES.
2. THE CONTRACTOR SHALL TAKE ALL DUE CARE TO PREVENT OVER-COMPACTING OF UNDERLYING SOILS IN AREAS OF PROPOSED STORMWATER INFILTRATION MEASURES, BY MARKING OFF THE LOCATION BEFORE THE START OF CONSTRUCTION AND CONSTRUCTING THE INFILTRATION PRACTICE LAST, CONNECTING UPSTREAM DRAINAGE AREAS ONLY AFTER CONSTRUCTION IS COMPLETE AND THE CONTRIBUTING AREA IS STABILIZED.
3. INFILTRATION PRACTICES SHALL NEVER SERVE AS SEDIMENT CONTROL DEVICES DURING THE SITE CONSTRUCTION PHASE. THE CONTRACTOR SHALL SUBMIT A PLAN TO THE DESIGNATED AUTHORITY (FOR APPROVAL) INDICATING HOW SEDIMENT WILL BE PREVENTED FROM ENTERING THE AREA OF AN INFILTRATION FACILITY.
4. ANY ACCUMULATED SEDIMENT SHALL BE REMOVED DOWN TO NATIVE UNDISTURBED MATERIAL PRIOR TO CONSTRUCTING THE FINAL INFILTRATION PRACTICES.
5. IF NECESSARY OR DIRECTED, THE CONTRACTOR SHALL RESTORE THE INFILTRATION CAPACITY OF ALL COMPACTED IN-SITU SOILS BENEATH INFILTRATION MEASURES BY TILLING OR SCARIFYING COMPACTED SOILS TO A MINIMUM DEPTH OF 18" BENEATH THE BOTTOM OF THE PROPOSED INFILTRATION MEASURE.
6. THE DESIGNATED AUTHORITY MAY REQUIRE THE CONTRACTOR TO PERFORM, AT ITS SOLE EXPENSE, INFILTRATION TESTING OF THE IN-SITU SUBGRADE SOILS PRIOR TO INSTALLATION OF THE INFILTRATION PRACTICE TO DEMONSTRATE THAT THE NECESSARY SOIL INFILTRATION CAPACITY WILL BE PROVIDED BY THE UNDERLYING SOILS.

SUGGESTED SEQUENCE & STAGING OF WORK:

1. NOTIFY RIDEM AND THE TOWN PRIOR TO THE START OF EARTH DISTURBING ACTIVITIES (REFER TO THE SPECIFIC NOTIFICATION REQUIREMENTS FOR EACH ENTITY).
 2. SURVEY AND STAKE LIMITS OF DISTURBANCE FOR PLACEMENT OF PERIMETER SESC MEASURES.
 3. PERFORM LIMITED VEGETATIVE CLEARING (BUT NOT GRUBBING) SUFFICIENT FOR THE INSTALLATION OF PERIMETER SESC MEASURES, AND INSTALL PERIMETER SESC MEASURES. IN NO CASE SHALL THE LIMIT OF WORK EXTEND BEYOND SAID PERIMETER MEASURES.
 4. CONSTRUCT CONSTRUCTION ENTRANCE PAD FROM BROAD ROCK ROAD.
 5. CLEAR AND GRUB PROPOSED COMMON DRIVEWAY AREA WITHIN THE LIMIT OF DISTURBANCE AND PROPOSED TEMPORARY SEDIMENTATION BASIN (TSB) AREAS, AND SUFFICIENT OFF-DRIVEWAY STAGING/STORAGE AREAS FOR MATERIAL STOCKPILES, VEHICLES AND EQUIPMENT. MINIMIZE CLEARING & GRUBBING OF OFF-DRIVEWAY AREAS TO THE EXTENT PRACTICABLE.
 6. CONSTRUCT TEMPORARY SEDIMENT BASIN (TSB) AND EARTH BERMS THAT SHALL FEED TO THE TSB. ENSURE THAT ALL BASIN AND WATERWAY SURFACES ARE ADEQUATELY STABILIZED PRIOR TO START OF COMMON DRIVEWAY/UTILITY CONSTRUCTION.
 7. ROUGH-GRADE PROPOSED COMMON DRIVEWAY TO PROPOSED SUBBASE ELEVATIONS. INSTALL PROPOSED STORM DRAINAGE COLLECTION, CONVEYANCE SYSTEMS. ENSURE THAT NO RUNOFF FROM UNSTABILIZED AREAS ENTERS THE NEW DRAINAGE SYSTEM. INSTALL BALED STRAW SEDIMENTATION CHECKS IN GRASSED SWALES.
 8. INSTALL AND PRESSURE-TEST PROPOSED PRIVATE WATER SYSTEM PIPING, FITTINGS AND APPURTENANCES.
 9. INSTALL COMMON DRIVEWAY GRAVEL BASE COURSE; ALLOW TO WEATHER FOR MINIMUM SIXTY (60) DAYS AFTER COMPLETION OF UTILITY (STORM DRAINAGE & WATER) WORK.
 10. FINE-GRADE AND COMPACT GRAVEL BASE COURSE AFTER WEATHERING PERIOD AND INSTALL COMMON DRIVEWAY BITUMINOUS CONCRETE PAVEMENT BASE COURSE.
 11. REMOVE TEMPORARY SEDIMENT TRAPS & EARTH BERMS AS THE SITE DEVELOPS AND IS STABILIZED.
 12. CONSTRUCT STORMWATER INFILTRATION POND AND STABILIZE.
 13. CONSTRUCT PROPOSED DWELLING UNITS AND ASSOCIATED SITE FEATURES (E.G. INDIVIDUAL PAVED DRIVEWAYS, ROOF DRAIN INFILTRATION UNITS, OWTS, OFF-ROAD GRADING & LANDSCAPING).
 14. DWELLING CONSTRUCTION MAY BE PHASED OVER MULTIPLE CONSTRUCTION SEASONS; MAINTAIN AND ADJUST INTERIOR SESC MEASURES AS APPROPRIATE DURING ALL PHASES OF THIS CONSTRUCTION, IN ACCORDANCE WITH THE SESC PLAN.
 15. INSTALL COMMON DRIVEWAY BITUMINOUS CONCRETE SURFACE COURSE.
 16. CLEAN OUT ALL DRAINAGE STRUCTURES AS NEEDED, REMOVE AND LEGALLY DISPOSE ALL ACCUMULATED SEDIMENT IN A SUITABLE OFF-SITE LOCATION.
 17. UPON COMMENCEMENT OF SITE CONSTRUCTION ACTIVITIES, THE OPERATOR SHALL INITIATE APPROPRIATE STABILIZATION PRACTICES ON ALL DISTURBED AREAS AS SOON AS POSSIBLE, BUT NOT MORE THAN FOURTEEN (14) DAYS AFTER THE CONSTRUCTION ACTIVITY IN THAT AREA HAS TEMPORARILY OR PERMANENTLY CEASED. SUCH TEMPORARY OR PERMANENT SOIL STABILIZATION MEASURES MUST BE INSTALLED PRIOR TO INITIATING LAND DISTURBANCE IN SUBSEQUENT PHASES.
 18. ROUTINE INSPECTION AND MAINTENANCE AND/OR MODIFICATION OF EROSION, RUNOFF, AND SEDIMENT CONTROLS AND TEMPORARY POLLUTION PREVENTION MEASURES WHILE EARTHWORK IS ONGOING IS REQUIRED.
 19. FINAL SITE STABILIZATION OF ANY DISTURBED AREAS AFTER EARTHWORK HAS BEEN COMPLETED AND REMOVAL OF TEMPORARY EROSION, RUNOFF, AND SEDIMENT CONTROLS AND TEMPORARY POLLUTION PREVENTION MEASURES.
- NOTE: THE DEVELOPER MAY MODIFY THE PRECEDING SUGGESTED SEQUENCE OF CONSTRUCTION IF NECESSARY OR PRACTICAL, SO LONG AS THE INTENT OF THE SESC PLAN IS MET AT ALL TIMES.

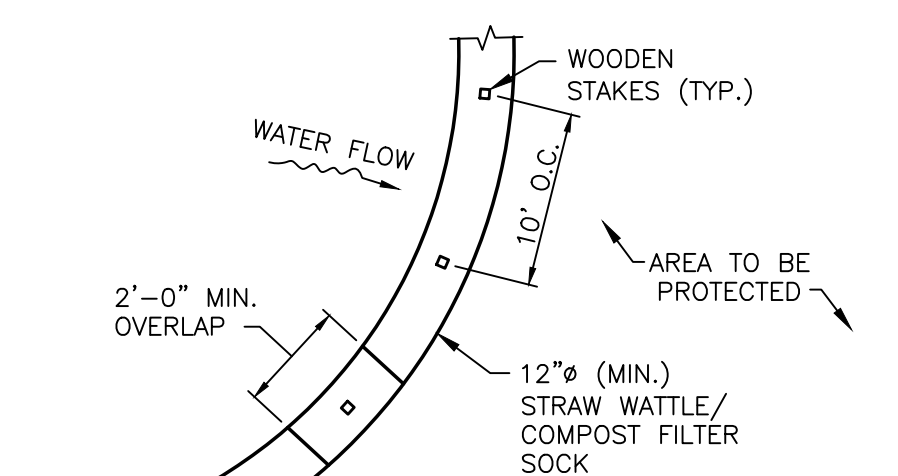

STRAW WATTLE/COMPOST FILTER SOCK

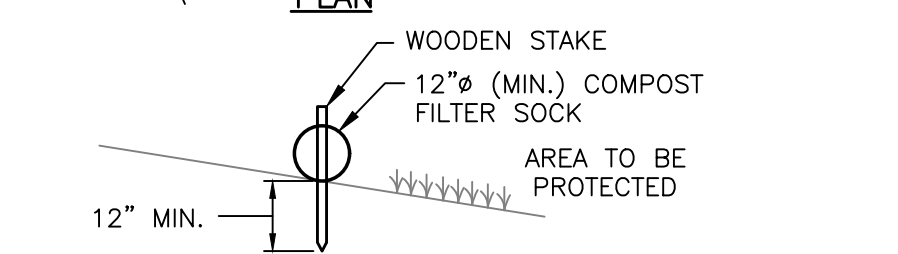

SECTION

- NOTES:**
1. ALL MATERIAL TO MEET REQUIREMENTS OF SECTION 206 OF RI STANDARD SPECIFICATIONS.
 2. SUBMIT SHOP DRAWING OF COMPOST MATERIAL FOR REVIEW AND APPROVAL PRIOR TO PLACEMENT.
 3. COMPOST FILTER SOCK IS AN APPROVED "OR EQUAL" TO COMPOST FILTER BERM WHEN INSTALLED IN ACCORDANCE WITH THE TABLE BELOW:

MAXIMUM LENGTH ABOVE COMPOST FILTER SOCK (FEET) AND CORRESPONDING DIAMETER OF SOCK REQUIRED:

UPGRADE SLOPE	8"φ	12"φ	18"φ	24"φ
2%	300'	375'	500'	650'
5%	200'	250'	275'	325'
10%	100'	125'	150'	200'
20%	50'	65'	70'	130'
30%	30'	40'	45'	85'
40%	30'	40'	45'	50'
50%	20'	25'	30'	35'

STRAW WATTLE/COMPOST FILTER SOCK

EROSION CONTROL AND SOIL STABILIZATION PROGRAM:

1. TEMPORARY TREATMENTS SHALL CONSIST OF A STRAW, FIBER MULCH OR PROTECTIVE COVERS SUCH AS A MAT OR FIBER LINING (BURLAR, JUTE, FIBERGLASS NETTING, EXCELSIOR BLANKETS). THEY SHALL BE INCORPORATED INTO THE WORK AS WARRANTED OR AS ORDERED BY THE ENGINEER.
2. STRAW APPLICATIONS SHOULD BE IN THE AMOUNT OF 2000 LBS/ACRE.
3. ALL STRAW BALES OR TEMPORARY PROTECTION SHALL REMAIN IN-PLACE UNTIL AN ACCEPTABLE STAND OF GRASS OR APPROVED GROUND COVER IS ESTABLISHED.
4. THE TOPSOIL SHALL HAVE A SANDY LOAM TEXTURE RELATIVELY FREE OF SUBSOIL MATERIAL, STONES, ROOTS, LUMPS OF SOIL, TREE LIMBS, TRASH OR CONSTRUCTION DEBRIS AND SHALL CONFORM WITH RHODE ISLAND STANDARD SPECIFICATION M.20.01, AS AMENDED. THE SEED MIX SHALL BE INOCULATED WITHIN 24-HOURS BEFORE MIXING AND PLANTING, WITH APPROPRIATE INOCULUM FOR EACH VARIETY.
6. THE DESIGN MIX UTILIZED IN ALL DISTURBED AREAS TO BE SEEDED SHALL BE COMPRISED OF THE FOLLOWING:

TYPE	% BY WEIGHT	SEEDING DATE	CREeping RED
FESCUE	70	APRIL 1 - JUNE 15	
ASTORIA BENTGRASS	5		
BIRDFOOT TREEFOIL	15	AUGUST 15 - OCT.	
PERENNIAL RYEGRASS	10		
APPLICATION RATE	100 LBS/ACRE		
LIMING AND FERTILIZING AS REQUIRED TO COMPLIMENT OR EXISTING CONDITIONS.			UPGRADE
7. THE CONTRACTOR MUST REPAIR AND/OR RESEED ANY AREAS THAT DO NOT DEVELOP WITHIN THE PERIOD OF ONE YEAR, AND SHALL DO SO AT NO ADDITIONAL EXPENSE.
8. THE NORMAL ACCEPTABLE SEASONAL SEEDING DATES ARE APRIL 1ST THROUGH OCTOBER 15TH.
9. STABILIZATION OF ONE FORM OR ANOTHER AS DESCRIBED ABOVE SHALL BE ACHIEVED WITHIN FIFTEEN (15) DAYS OF FINAL GRADING.
10. STOCKPILES OF TOPSOIL AND EARTH MATERIALS SHALL NOT BE LOCATED NEAR WATERWAYS. THEY SHALL HAVE SIDE SLOPES NO GREATER THAN THIRTY PERCENT (30%) AND STOCKPILE SHALL ALSO BE SEEDED AND/OR STABILIZED.
11. ON BOTH STEEP AND LONG SLOPES, CONSIDERATION SHOULD BE GIVEN TO "CRIMPING" OR "TRACKING" TO TACK DOWN MULCH APPLICATIONS.
12. TREES TO BE RETAINED SHALL BE FENCED OR ROPED OFF TO PROTECT THEM FROM CONSTRUCTION EQUIPMENT.
13. ALL PROPOSED PLANTINGS MUST BE ACCOMPLISHED AS EARLY AS POSSIBLE UPON COMPLETION OF GRADING AND CONSTRUCTION, AND AT LEAST PRIOR TO ANY ON-SITE OCCUPANCY.
14. ALL PROPOSED PLANTINGS MUST BE MAINTAINED BY THE PROPERTY OWNER TO ENSURE SURVIVAL.
15. SHOULD ANY OR ALL OF THE PROPOSED PLANTS FAIL TO SURVIVE AT LEAST ONE (1) FULL GROWING SEASON FROM THE TIME THEY HAVE BEEN PLANTED, THE OWNER SHALL BE FULLY RESPONSIBLE FOR REPLACING AND MAINTAINING THE SAME PLANT SPECIES FOR ONE (1) ADDITIONAL GROWING SEASON.
16. ALL DISTURBED AREAS MUST BE SEEDED OR PLANTED WITHIN THE CONSTRUCTION SEASON.
17. TEMPORARY SEEDING MUST BE DONE WITHIN ONE (1) MONTH AFTER DISTURBANCE.
18. ALL DISTURBED AREAS MUST BE PERMANENTLY SEED OR PLANTED BEFORE OCTOBER 1ST, IF NOT THEY MUST BE TEMPORARILY SEED.
19. SLOPES CONSTRUCTED AT, OR STEEPER THAN, 15% SHALL HAVE TEMPORARY EROSION CONTROL MATTING UTILIZED AS A SUPPORTIVE METHOD IN ADDITION TO THE METHODS DESCRIBED ABOVE.
20. ALL PROPOSED INLETS AND OUTLETS SHALL BE PROTECTED WITH RIPRAP BOTH TEMPORARILY AND PERMANENTLY. SEE DETAIL.
21. ALL CONSTRUCTION SHALL BE IN ACCORDANCE WITH THE STANDARDS AND PROCEDURES SET FORTH IN THE CITY SUBDIVISION REGULATIONS AND ZONING ORDINANCES, RHODE ISLAND STORMWATER DESIGN AND INSTALLATION STANDARDS MANUAL DEC. 2010 AS PREPARED BY THE RIDEM AND CRMC, AND RHODE ISLAND EROSION AND SEDIMENT CONTROL HANDBOOK AS PREPARED BY RHODE ISLAND STATE CONSERVATION COMMITTEE, REVISED 2014, (AS REVISED).
22. INFILTRATION PRACTICES SHALL NEVER SERVE AS A SEDIMENT CONTROL DEVICE DURING SITE CONSTRUCTION PHASE. GREAT CARE MUST BE TAKEN TO PREVENT ANY INFILTRATION AREA FROM COMPACTION BY MARKING OFF THE LOCATION BEFORE THE START OF

CONSTRUCTION AT THE SITE AND CONSTRUCTING THE INFILTRATION PRACTICE LAST, CONNECTING UPSTREAM DRAINAGE AREAS ONLY AFTER CONSTRUCTION IS COMPLETE, AND THE CONTRIBUTING AREA IS STABILIZED. THE CONTRACTOR SHALL SUBMIT A PLAN TO THE TOWN (FOR APPROVAL) HOW SEDIMENT WILL BE PREVENTED FROM ENTERING THE SITE OF AN INFILTRATION FACILITY.

EXTREME CARE SHALL BE EXERCISED AS TO PREVENT ANY MATERIALS FROM ENTERING WETLANDS, THE ROADWAYS, ROADWAY DRAINAGE SYSTEMS, AND ADJACENT PROPERTY. STAKED STRAW BALES OR SILT FENCE SHALL BE INSTALLED WHERE SHOWN ON THE PLAN AND AS REQUIRED TO PREVENT SEDIMENTATION ONTO ADJACENT PROPERTIES, WETLANDS AND THE ROADWAY DRAINAGE SYSTEM.

NO UNDISTURBED AREAS SHALL BE CLEARED OF EXISTING VEGETATION AFTER OCTOBER 15 OF ANY CALENDAR YEAR OR DURING ANY PERIOD OF FULL OR LIMITED WINTER SHUTDOWN. ALL DISTURBED SOILS EXPOSED PRIOR TO COVERED BY ANY CALENDAR YEAR SHALL BE SEED OR PROTECTED BY THAT DATE. ANY SUCH AREAS THAT DO NOT HAVE ADEQUATE VEGETATIVE STABILIZATION, AS DETERMINED BY THE RESIDENT ENGINEER OR ENVIRONMENTAL INSPECTOR, BY NOVEMBER 15 OF ANY CALENDAR YEAR, MUST BE STABILIZED THROUGH THE USE OF EROSION CONTROL MATTING OR STRAW MULCH, IN ACCORDANCE WITH SPECIFICATIONS CONTAINED WITHIN THE RI, SOIL EROSION AND SEDIMENT CONTROL HANDBOOK. IF WORK CONTINUES WITHIN ANY OF THESE AREAS DURING THE PERIOD FROM OCTOBER 15 THROUGH APRIL 15, CARE MUST BE TAKEN TO ENSURE THAT ONLY THE AREA REQUIRED FOR THAT DAY'S WORK IS EXPOSED, AND ALL ERODIBLE SOIL MUST BE RESTABILIZED WITHIN 5 WORKING DAYS. ANY WORK TO CORRECT PROBLEMS RESULTING FROM FAILURE TO COMPLY WITH THIS PROVISION SHALL BE THE RESPONSIBILITY OF THE CONTRACTOR. THERE WILL BE NO SEPARATE PAYMENT FOR THIS PROVISION. IT SHALL BE CONSIDERED INCIDENTAL TO CONSTRUCTION OPERATIONS. STABILIZATION OF ONE FORM OR ANOTHER AS DESCRIBED ABOVE SHALL BE ACHIEVED WITHIN 2 WEEKS OF FINAL GRADING. PREPARE TEMPORARY SEEDING AREA, PROVIDE AND PLANT SEED IN ACCORDANCE WITH "RHODE ISLAND EROSION AND SEDIMENT CONTROL HANDBOOK" AS PREPARED BY THE RHODE ISLAND STATE CONSERVATION COMMITTEE, REVISED 2014, (AS REVISED).

SEED MIX:
ANNUAL RYE GRASS 1.5 LBS/1,000 SQ. FT.

TEMPORARY TREATMENTS TO STABILIZE EXPOSED SOILS SHALL CONSIST OF STRAW OR FIBER MULCH OR PROTECTIVE COVERS, SUCH AS A MAT OR FIBER LINING (BURLAR, JUTE, FIBERGLASS NETTING, EXCELSIOR BLANKETS). THEY SHALL BE INCORPORATED INTO THE WORK WHEN SOILS ARE EXPOSED FOR TWO WEEKS OR MORE OR AS ORDERED BY THE TOWN, ENGINEER OR OWNER AT NO ADDITIONAL COST. STRAW APPLICATIONS SHALL BE IN THE AMOUNT OF 3,000-4,000 LBS/ACRE. ALL NEW STRAW BALES OR TEMPORARY PROTECTION SHALL REMAIN IN PLACE UNTIL AN ACCEPTABLE STAND OF GRASS OR APPROVED GROUND COVER IS ESTABLISHED AND POTENTIAL SEDIMENTATION SOURCES ARE REMOVED. STOCKPILES SHALL HAVE NO SLOPE GREATER THAN 2:1 AND SHALL BE SURROUNDED BY STAKED STRAW BALES OR SILT FENCE. STOCKPILES EXPOSED FOR EXCESSIVE PERIODS OF TIME SHALL RECEIVE TEMPORARY TREATMENT CONSISTING OF PLANTING ANNUAL RYE GRASS OR PROTECTING WITH STRAW OR FIBER MATTING. DURING CONSTRUCTION, THE CONTRACTOR SHALL BE RESPONSIBLE FOR ALL EROSION CONTROL MAINTENANCE AND SHALL INSPECT/REPLACE AS NEEDED. ADDITIONAL STRAW BALES/SILT FENCE OR OTHER TREATMENTS SHALL BE PROVIDED AS DIRECTED BY ENGINEER, RIDEM OR LOCAL REPRESENTATIVES AT NO ADDITIONAL COST. THE CONTRACTOR SHALL INSPECT THE SOIL EROSION CONTROL DEVICES AFTER EVERY RAIN STORM EVENT AND EVERY 7 DAYS (WHICH EVER COMES FIRST). ANY SOIL MIGRATION PAST THE DEVICES SHALL BE REMOVED AND THE SOIL EROSION CONTROL DEVICES SHALL BE RE-ESTABLISHED TO PREVENT SOIL EROSION. ALL ACCUMULATED SEDIMENT IN FRONT OF THE DEVICES SHALL BE REMOVED AFTER EVERY RAIN STORM EVENT. ALL DISTURBED SOIL AREAS SHALL BE PROTECTED AGAINST SOIL EROSION BY PLACEMENT OF STRAW BALES AND/OR SILT FENCE ON THE DOWN GRADIENT SIDE OF THE DISTURBED AREAS(S). SHOULD THE VOLUME AND/OR RATE OF STORMWATER RUNOFF BE TOO GREAT FOR A SINGLE DEVICE, THEN MULTIPLE DEVICES ARE REQUIRED SUCH AS SILT FENCE BACKED-UP WITH STRAW BALES. THESE ADDITIONAL DEVICES ARE NOT SHOWN ON THE PLAN BUT SHALL BE PROVIDED AND INSTALLED BY THE CONTRACTOR AT NO ADDITIONAL COST TO THE OWNER. AT THE END OF THE PROJECT ALL SEDIMENT IN MANHOLE SUMPS SHALL BE REMOVED.

TIMOTHY J. BEHAY
REGISTERED PROFESSIONAL ENGINEER
11/24/2024

COMMONWEALTH ENGINEERS & CONSULTANTS, INC.
400 SMITH STREET
PROVIDENCE, RHODE ISLAND 02908
(401) 273-6600

PERMIT AGENCY REVIEW PLAN
FOR
VILLAGE AT BROAD ROCK
PLAT 33, LOT 24
ON
BROAD ROCK ROAD
SOUTH KINGSTOWN, RHODE ISLAND
SOIL EROSION AND SEDIMENT CONTROL DETAILS

No.	DATE	DRWN	CHKD
1	4/2/24	TB	TB
2	4/18/24	TB	TB
3	9/6/24	SMA	TB
4	9/30/24	SMA	TB
5	10/21/24	SMA	TB
6	11/24/24	SMA	TB

SCALE: AS SHOWN SHEET NO: 11 OF 17
DRAWN BY: SMA DESIGN BY: SMA CHECKED BY: TJB
DATE: FEBRUARY 2024 PROJECT NO: 23011.00

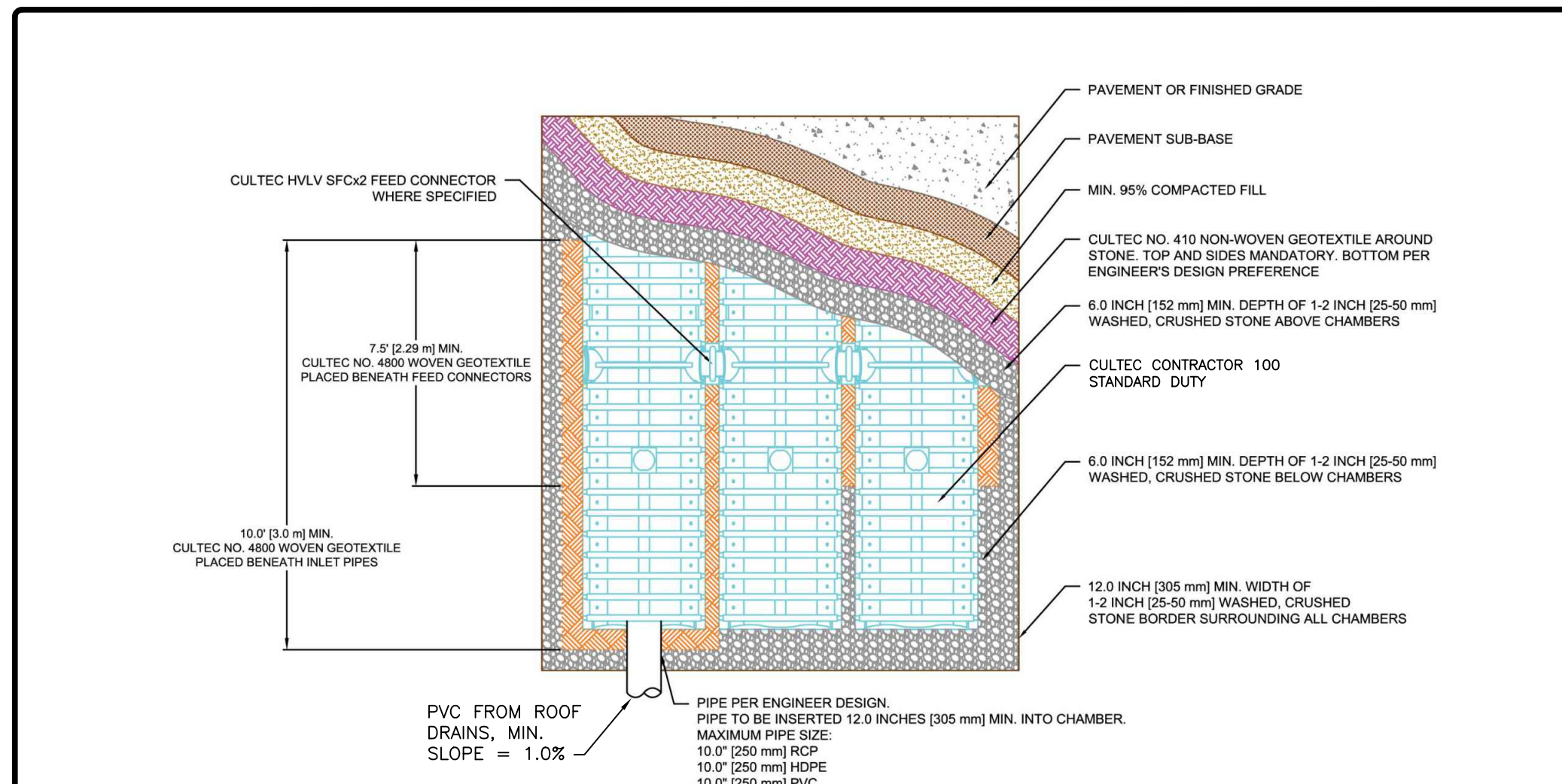

CULTEC PLAN
NOT TO SCALE

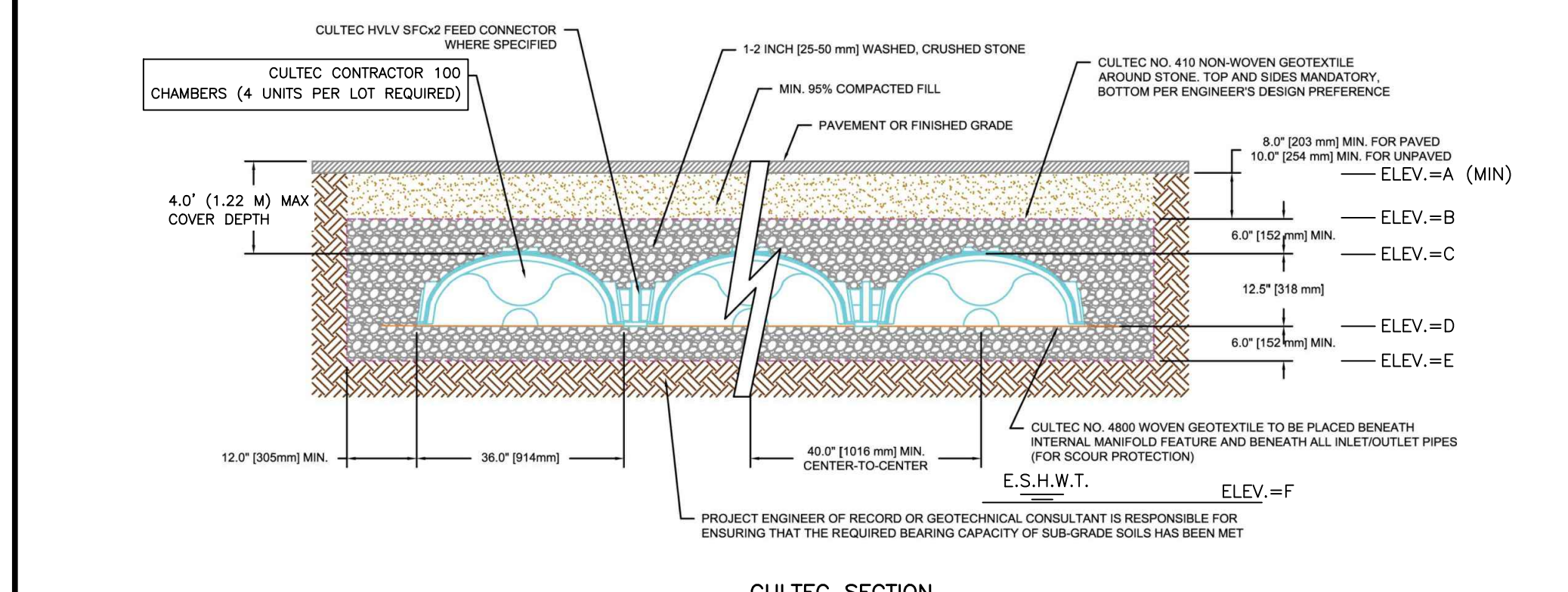

CULTEC SECTION
NOT TO SCALE

ROOF INFILTRATION SYSTEM DETAILS & NOTES

- NOTE:**
- REMOVE ALL LEDGE WITHIN 5' OF BOTTOM OF SYSTEM, IF APPLICABLE.
 - KEEP CHAMBER FIELD AT LEAST 15' OFF SEPTIC DRAIN FIELD, 10' OFF BASEMENTS (UNLESS LOCATED BELOW SLAB ELEVATION) AND 50 FEET OFF WELLS.

ROOF INFILTRATION ELEVATION SUMMARY

LOT	A= MIN. COVER ELEV. (FT.)	B=TOP COVER STONE ELEV. (FT.)	C=TOP CHAMBER ELEV. (FT.)	D= BOTTOM CHAMBER (INLET) ELEV. (FT.)	E=BOTTOM STONE ELEV. (FT.)	F=ESHGW ELEV. (FT.)
LOT-1	81.64	80.64	80.14	79.10	78.60	76.00
LOT-2	80.24	79.24	78.74	77.70	77.20	75.00
LOT-3	77.54	76.54	76.04	75.00	74.50	72.00
LOT-4	75.74	74.74	74.24	73.20	72.70	70.50
LOT-5	68.04	67.04	66.54	65.50	65.00	62.00
LOT-6	65.79	64.79	64.29	63.25	62.75	60.00
LOT-7	70.04	69.04	68.54	67.50	67.00	64.00
LOT-8	72.04	71.04	70.54	69.50	69.00	66.00
LOT-9	77.24	76.24	75.74	74.70	74.20	72.00
LOT-10	78.24	77.24	76.74	75.70	75.20	73.00
LOT-11	72.04	71.04	70.54	69.50	69.00	66.00
LOT-12	66.24	65.24	64.74	63.70	63.20	61.00
LOT-13	61.24	60.24	59.74	58.70	58.20	56.00
LOT-14	60.24	59.24	58.74	57.70	57.20	55.00
LOT-15	57.04	56.04	55.54	54.50	54.00	48.50
LOT-16	66.04	65.04	64.54	63.50	63.00	59.00
LOT-17	70.54	69.54	69.04	68.00	67.50	63.50
LOT-18	75.54	74.54	74.04	73.00	72.50	69.00
LOT-19	79.04	78.04	77.54	76.50	76.00	72.00

- CULTEC SYSTEM NOTES:**
- ALL WORK PERFORMED IN ACCORDANCE WITH CULTEC RECOMMENDATIONS.
 - CULTEC SYSTEM INSTALLATION MUST BE INSPECTED BY THE PROJECT ENGINEER.
 - CULTEC SYSTEMS MAY BE SPLIT INTO TWO SYSTEMS EACH RECEIVING HALF OF THE ROOF AREA.
 - INFILTRATION SYSTEM CHAMBERS SHALL BE CULTEC CONTRACTOR 100 UNITS.
 - STONE AROUND INFILTRATORS SHALL BE WASHED, CRUSHED STONE.
 - CULTEC SYSTEMS SHALL BE LOCATED 25' MIN. FROM DWG'S, 50' FROM WELLS AND 10' MIN. FROM BUILDINGS AND PROPERTY LINES.
 - ALL PIPE UNDER DRIVEWAYS SHALL BE SDR35 PVC OR APPROVED EQUAL AND BEDDED IN 2" CRUSHED STONE 8" MIN. AROUND PIPE.

- CULTEC SYSTEM MAINTENANCE NOTES:**
- INFILTRATOR CHAMBERS SHALL BE PERIODICALLY INSPECTED AND MAINTAINED DURING CONSTRUCTION AND A MINIMUM OF TWICE PER YEAR UPON COMPLETION OF CONSTRUCTION.
 - THE CONTRACTOR SHALL BE RESPONSIBLE FOR INSPECTION AND MAINTENANCE OF ALL DRAINAGE FACILITIES, AS PER THEIR RESPECTIVE PROGRAMS, UNTIL FINAL ACCEPTANCE BY THE OWNER.
 - UPON FINAL ACCEPTANCE, THE OWNER SHALL BE RESPONSIBLE FOR ALL DRAINAGE INSPECTION AND MAINTENANCE.
 - ANY INADVERTENT OR DELIBERATE DISCHARGE OF WASTE OIL OR ANY OTHER POLLUTANT TO THE STORMWATER DISPOSAL SYSTEM REQUIRES IMMEDIATE NOTIFICATION OF THE RIDEM-UIC PROGRAM.
 - ANY INCIDENT OF GROUNDWATER CONTAMINATION RESULTING FROM THE IMPROPER DISCHARGE OF CONTAMINANTS TO THE DISPOSAL SYSTEM SHALL BE THE RESPONSIBILITY OF THE PROPERTY OWNER. THE RIDEM WILL REQUIRE THE PROPERTY OWNER TO REMEDIATE ANY INCIDENTS THAT MAY ADVERSELY IMPACT THE QUALITY OF THE GROUNDWATER.
 - VEHICLE TRAFFIC OVER THE SYSTEM IS NOT PERMITTED.

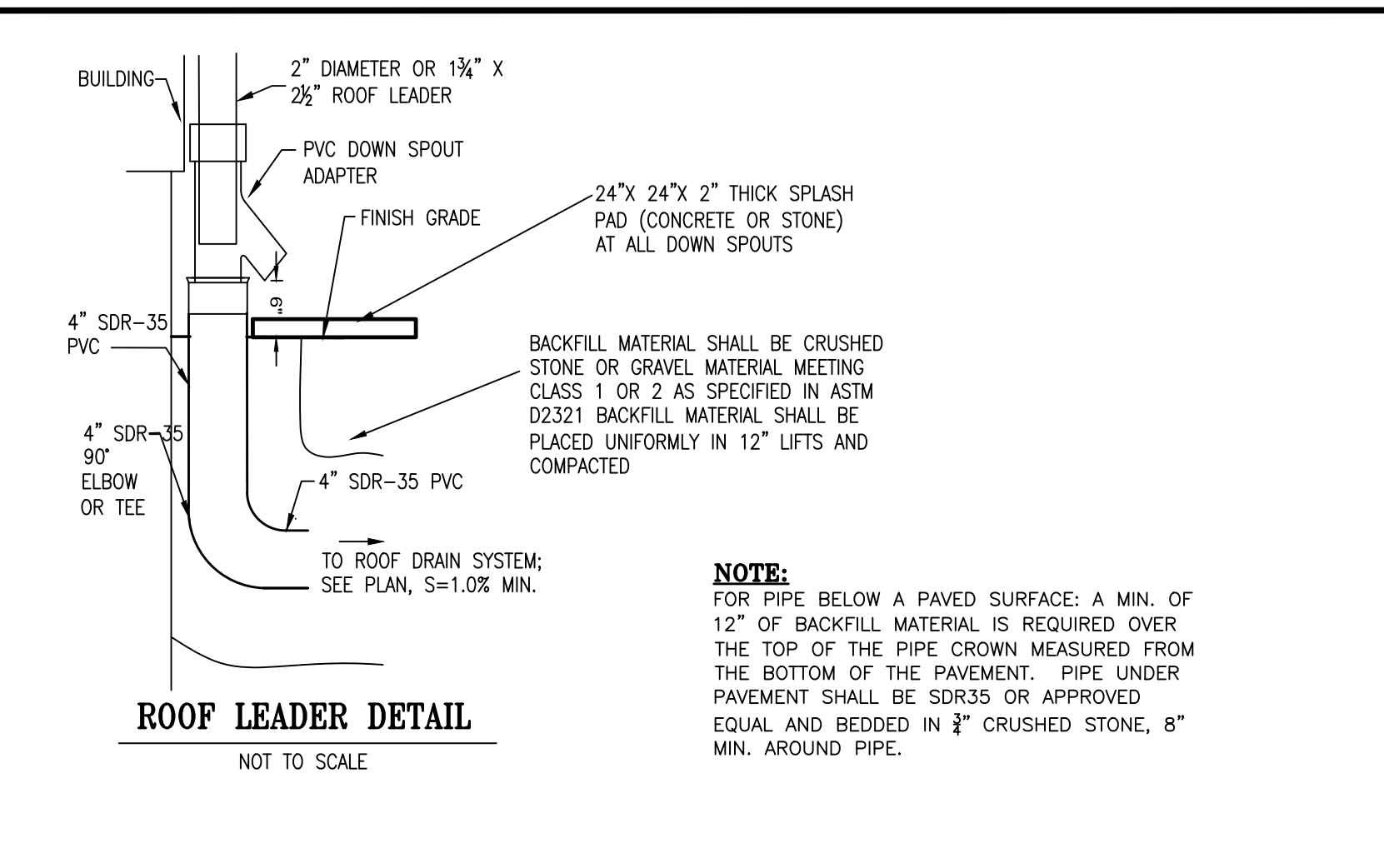

ROOF LEADER DETAIL
NOT TO SCALE

NOTE:
FOR PIPE BELOW A PAVED SURFACE, A MIN. OF 12" OF BACKFILL MATERIAL IS REQUIRED OVER THE TOP OF THE PIPE CROWN MEASURED FROM THE BOTTOM OF THE PAVEMENT. PIPE UNDER PAVEMENT SHALL BE SDR35 OR APPROVED EQUAL AND BEDDED IN 2" CRUSHED STONE, 8" MIN. AROUND PIPE.

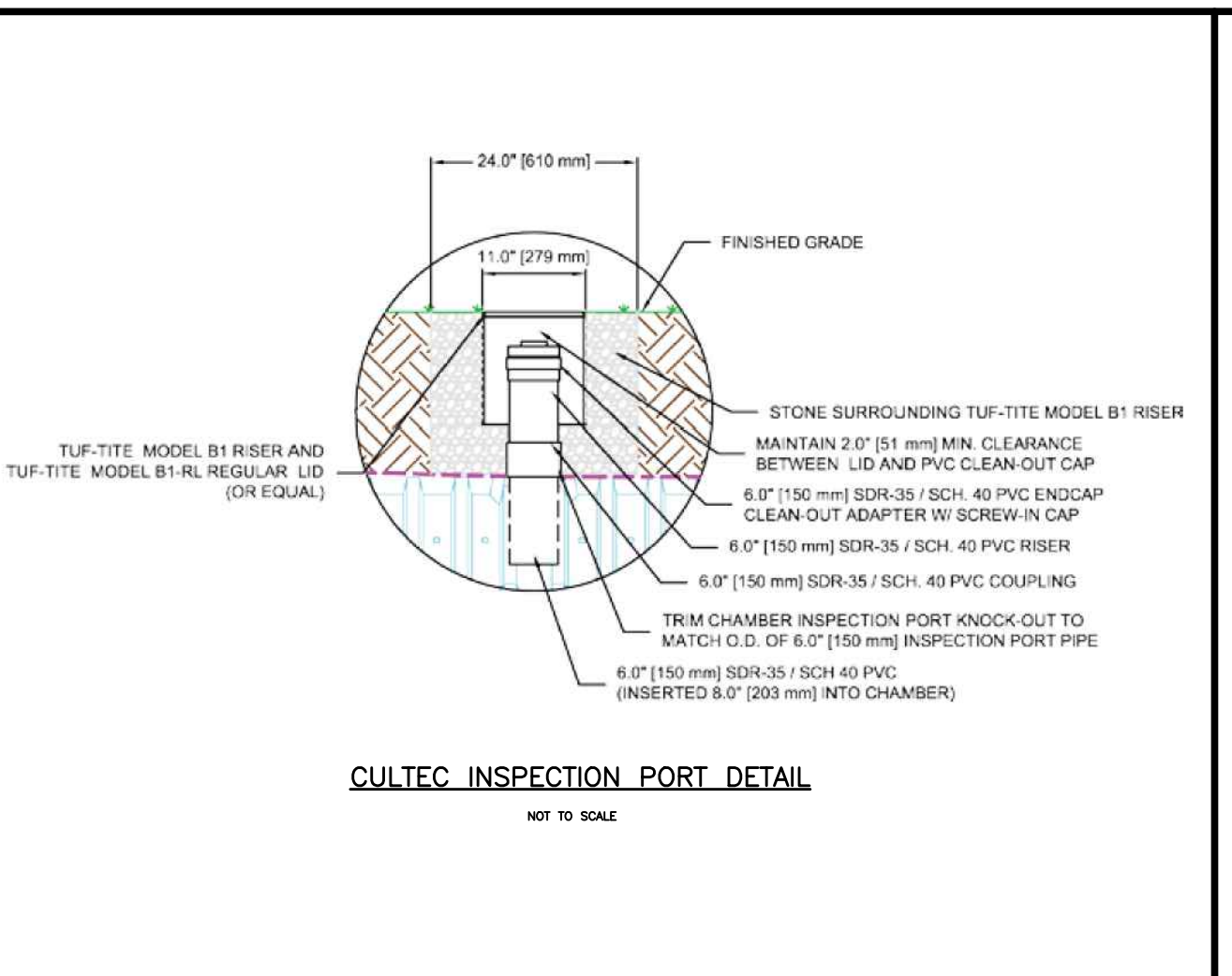

CULTEC INSPECTION PORT DETAIL
NOT TO SCALE

DRAINAGE SYSTEM-INSPECTION, MAINTENANCE & REPAIR:

- THE OWNER SHALL MAINTAIN THE PROPOSED DRAINAGE SYSTEM COMPONENTS WHICH INCLUDE THE CATCH BASINS, MANHOLES, PIPING, SWALE, SAND FILTERS, INFILTRATION PONDS AND DETENTION POND. A LEGALLY BINDING AND ENFORCEABLE MAINTENANCE AGREEMENT SHALL BE EXECUTED BETWEEN THE OWNER AND A MAINTENANCE COMPANY TRAINED AND EXPERIENCED WITH THE MAINTENANCE REQUIREMENTS DETAILED IN THE 'RHODE ISLAND STORMWATER DESIGN AND INSTALLATION STANDARDS MANUAL', LATEST EDITION KNOWN AS THE 'MANUAL'.
 - INSPECTIONS ARE ESSENTIAL FOR THE LONGEVITY OF THE DRAINAGE SYSTEMS. THE DRAINAGE SYSTEM SHALL BE INSPECTED IN ACCORDANCE WITH THE 'MANUAL' AND THE SITE-SPECIFIC OPERATION AND MANAGEMENT PLAN BY THE MAINTENANCE COMPANY. RECORDS OF INSPECTIONS SHALL BE MAINTAINED BY THE OWNER AND MAINTENANCE COMPANY. IN NO CASE SHALL LESS THAN TWO INSPECTIONS OCCUR EACH CALENDAR YEAR, TYPICALLY SPRING AND FALL. THE ENTIRE SYSTEM SHALL ALSO BE INSPECTED AFTER STORM EVENTS GREATER THAN OR EQUAL TO THE 1-YEAR, 24-HOUR TYPE III PRECIPITATION EVENT (2.7 INCHES OF RAIN).
 - INSPECTIONS SHALL BE IN ACCORDANCE WITH THE 'MANUAL'. A SUMMARY OF THE REQUIREMENTS ARE DESCRIBED BELOW, THE MAJORITY OF WHICH IS TAKEN DIRECTLY FROM THE 'MANUAL'. THE INSPECTOR SHALL REFER TO THE 'MANUAL' FOR ADDITIONAL INSIGHT ON INSPECTION METHODS AND REQUIREMENTS. ALL CHECKLISTS IN THE MANUAL SHALL BE FILLED OUT BY THE INSPECTOR. ALL DEFICIENCIES DISCOVERED SHALL BE BROUGHT TO THE OWNER'S ATTENTION IN WRITING.
- DRAINAGE MANHOLES:**
DRAINAGE MANHOLES SHALL BE INSPECTED ON A QUARTERLY BASIS IN ADDITION TO INSPECTIONS AFTER STORM EVENTS GREATER THAN OR EQUAL TO THE 1-YEAR, 24-HOUR TYPE III PRECIPITATION EVENT (2.7 INCHES OF RAIN).
- SCHEDULED MAINTENANCE:**
- REMOVE TRASH AND LITTER.
 - REPAIR ALL STRUCTURAL DEFECTS IMMEDIATELY.
 - REMOVE ALL ACCUMULATED SEDIMENT AND DISPOSED OFF-SITE IN ACCORDANCE WITH STATE & FEDERAL REGULATIONS.
- SCHEDULED MAINTENANCE:**
CATCH BASINS SHALL BE CLEANED A MINIMUM OF ONE (1) TIME PER YEAR (PREFERABLY IN THE SPRING), REGARDLESS OF THE DEPTH OF ACCUMULATED MATERIAL IN THE CATCH BASINS AT THE TIME OF THE CLEANING.
- CORRECTIVE MAINTENANCE:**
IF AT ANY TIME THE DEPTH OF ACCUMULATED MATERIAL WITHIN THE CATCH BASIN IS GREATER THAN OR EQUAL TO TWO (2) FEET, ALL ACCUMULATED MATERIAL SHALL BE REMOVED FROM THE CATCH BASIN TO THE BOTTOM OF THE SUMP AND LEGALLY DISPOSED OF AT AN OFF-SITE LOCATION.

- PIPES & OUTLETS:**
- INSPECTIONS:**
DRAINAGE PIPES AND OUTLETS SHALL BE INSPECTED ON A QUARTERLY BASIS IN ADDITION TO INSPECTIONS AFTER STORM EVENTS GREATER THAN OR EQUAL TO THE 1-YEAR, 24-HOUR TYPE III PRECIPITATION EVENT (2.7 INCHES OF RAIN).
- SCHEDULED MAINTENANCE:**
- REMOVE TRASH AND LITTER.
 - INSPECT OUTLET RIP RAP AREAS. REPAIR ALL ERODED AREAS BY SUPPLEMENTING WITH MORE RIP RAP AND ESTABLISHING NEW VEGETATIVE GROWTH.
- CORRECTIVE MAINTENANCE:**
ALL CLOGGED OR SEDIMENT FILLED PIPES WHICH ARE MORE THAN 10% SEDIMENT FILLED SHALL BE CLEANED OUT IMMEDIATELY. WHEN CLEANING OUT PIPES, ENSURE DOWNSTREAM AREAS ARE PROTECTED FROM SEDIMENT DISCHARGES. DISPOSE OFF-SITE IN ACCORDANCE WITH STATE & FEDERAL REGULATIONS.

- GRASS SWALE:**
- INSPECTIONS:**
THE GRASS SWALE SHALL BE INSPECTED ON AN ANNUAL BASIS AND AFTER STORMS OF GREATER THAN OR EQUAL TO THE 1-YEAR, 24-HOUR TYPE III PRECIPITATION EVENT (2.7 INCHES OF RAIN).
- SCHEDULED MAINTENANCE:**
THE MAINTENANCE OBJECTIVE FOR THIS PRACTICE INCLUDES PRESERVING THE HYDRAULIC AND REMOVAL EFFICIENCY OF THE CHANNEL AND MAINTAINING A DENSE, HEALTHY VEGETATIVE COVER. THE FOLLOWING ACTIVITIES ARE RECOMMENDED ON AN ANNUAL BASIS OR AS NEEDED:
- MOWING AND LITTER/ DEBRIS REMOVAL. MAINTAIN AN AVERAGE 6-INCH GRASS HEIGHT.
 - STABILIZATION OF ERODED SIDE SLOPES AND BOTTOM.
 - NUTRIENT AND PESTICIDE USE MANAGEMENT.
 - DE-THATCHING SWALE BOTTOM AND REMOVAL OF THATCHING, AND
 - DISKING OR AERATION OF SWALE BOTTOM.
- ALL RIP RAP CHECK DAMS SHALL BE REFRESHED AS REQUIRED TO MAINTAIN VOID SPACE AND FLOW DIFFUSION EFFECTIVENESS; THIS SHALL CONSIST OF THE REMOVAL OF ACCUMULATED SEDIMENTS WITHIN THE RIP RAP VOIDS AND RESTORATION OF THE RIP RAP STONE TO ORIGINAL LIMITS AND GRADES.
- EVERY FIVE YEARS, SCRAPING OF THE CHANNEL BOTTOM AND REMOVAL OF SEDIMENT TO RESTORE ORIGINAL CROSS SECTION AND INFILTRATION RATE, AND SEEDING TO RESTORE GROUND COVER IS RECOMMENDED.

- CORRECTIVE MAINTENANCE:**
WHEN SEDIMENT ACCUMULATES TO A DEPTH OF APPROXIMATELY 3 INCHES, IT SHALL BE REMOVED, AND THE SWALE SHALL BE RECONFIGURED TO ITS ORIGINAL DIMENSIONS. THE VEGETATION IN THE GRASSES SWALE SHALL BE MOWED AS REQUIRED TO MAINTAIN HEIGHTS IN THE 4-6 INCH RANGE, WITH MANDATORY MOWING ONCE HEIGHTS EXCEED 10 INCHES. IF THE SURFACE OF THE GRASS SWALE BECOMES CLOGGED TO THE POINT THAT STANDING WATER IS OBSERVED ON THE SURFACE 48 HOURS AFTER PRECIPITATION EVENTS, THE BOTTOM SHALL BE ROTO-TILLED OR CULTIVATED TO BREAK UP ANY HARD-PACKED SEDIMENT, AND THEN RESEEDED. TRASH AND DEBRIS SHALL BE REMOVED AND PROPERLY DISPOSED OF.
- SEDIMENT FOREBAY:**
- INSPECTIONS:**
THE SEDIMENT FOREBAY SHALL BE INSPECTED QUARTERLY AND AFTER STORM EVENTS GREATER THAN OR EQUAL TO THE 1-YEAR, 24 HOUR TYPE III PRECIPITATION EVENT.
- SCHEDULED MAINTENANCE:**
- MATERIALS DEPOSITED ON THE SURFACE (E.G., TRASH AND LITTER) SHOULD BE REMOVED MANUALLY.
 - VEGETATION SHALL BE MAINTAINED AT LESS THAN 18" IN HEIGHT.
 - SEDIMENT/SILT SHALL BE REMOVED WHEN IT ACCUMULATES TO MORE THAN ONE-HALF THE DESIGN DEPTH.
- CORRECTIVE MAINTENANCE:**
IF STANDING WATER IS OBSERVED IN THE SEDIMENT FOREBAY FOR MORE THAN 36 HOURS AFTER A STORM EVENT, THEN THE TOP 6 INCHES OF MATERIAL SHALL BE REMOVED AND REPLACED WITH NEW MATERIAL. IF DISCOLORED OR CONTAMINATED MATERIAL IS FOUND BELOW THE REMOVED SURFACE THEN THAT MATERIAL SHALL ALSO BE REMOVED AND REPLACED UNTIL ALL CONTAMINATED SAND HAS BEEN REMOVED FROM THE SEDIMENT FOREBAY. THE MATERIAL SHALL BE DISPOSED OF IN ACCORDANCE WITH ALL APPLICABLE FEDERAL AND LOCAL REGULATIONS.

- THE BERM AROUND THE SEDIMENT FOREBAY SHALL BE INSPECTED FOR EROSION AND GULLYING. REINFORCE EXISTING RIPRAP IF RIPRAP IS FOUND TO BE DEFICIENT OR IF EROSION IS PRESENT AT THE OUTFALLS OF ANY CONTROL STRUCTURES, OR THE EXISTING RIPRAP HAS BEEN COMPROMISED. ALL STRUCTURAL COMPONENTS, WHICH INCLUDE, BUT ARE NOT LIMITED TO, TRASH RACKS, ACCESS GATES, VALVES, PIPES, WEIR WALLS, ORIFICE STRUCTURES, AND SPILLWAY STRUCTURES, SHALL BE INSPECTED AND ANY DEFICIENCIES SHALL BE REPORTED. THIS INCLUDES A VISUAL INSPECTION OF ALL STORMWATER CONTROL STRUCTURES FOR DAMAGE AND/OR ACCUMULATION OF SEDIMENT. ACCUMULATED SEDIMENT SHALL BE REMOVED FROM THE BASIN WHEN THE DEPTH OF SEDIMENT IS GREATER THAN 12 INCHES.

- INFILTRATION BASIN/DETENTION POND:**
- MAINTENANCE:**
A LEGALLY BINDING AND ENFORCEABLE MAINTENANCE AGREEMENT SHALL BE EXECUTED BETWEEN THE FACILITY OWNER AND THE RESPONSIBLE AUTHORITY TO ENSURE THE FOLLOWING:
INFILTRATION PRACTICES SHALL NEVER SERVE AS A SEDIMENT CONTROL DEVICE DURING SITE CONSTRUCTION PHASE. GREAT CARE MUST BE TAKEN TO PREVENT THE INFILTRATION AREA FROM COMPACTION BY MARKING OFF THE LOCATION BEFORE THE START OF CONSTRUCTION AT THE SITE AND CONSTRUCTING THE INFILTRATION PRACTICE LAST, CONNECTING UPSTREAM DRAINAGE AREAS ONLY AFTER CONSTRUCTION IS COMPLETE, AND THE CONTRIBUTING AREA IS STABILIZED.
- INSPECTIONS:**
INFILTRATION BASIN SHOULD BE INSPECTED A MINIMUM OF ONE (1) TIME PER YEAR, PREFERABLY IN THE SPRING. IN ADDITION, BASIN SHALL BE INSPECTED AFTER ANY STORM GREATER THAN OR EQUAL TO THE 1-YEAR, 24-HOUR, TYPE III STORM EVENT.
- SCHEDULED MAINTENANCE:**
- SEDIMENT, TRASH OR OTHER DEBRIS IN INFILTRATION BASIN SHALL BE CLEANED A MINIMUM OF ONE (1) TIME PER YEAR (PREFERABLY IN THE SPRING), REGARDLESS OF THE DEPTH OF ACCUMULATED MATERIAL IN THE BASIN AT THE TIME OF THE CLEANING.
 - MOW ALL VEGETATED BASIN SLOPES AT LEAST FOUR (4) TIMES ANNUALLY DURING THE GROWING SEASON (TYPICALLY APRIL-NOVEMBER); MAINTAIN GRASS AT A HEIGHT OF 4-6". REMOVE AND DISPOSE OF ANY AND ALL OTHER VEGETATION (BUSHES, SHRUBS, TREES) THAT MAY BEGIN TO GROW WITHIN THE BASIN BEFORE IT BECOMES ESTABLISHED.
 - ALL RIP RAP PADS SHALL BE REFRESHED AS REQUIRED TO MAINTAIN VOID SPACE AND FLOW DIFFUSION EFFECTIVENESS; THIS SHALL CONSIST OF THE REMOVAL OF ACCUMULATED SEDIMENTS WITHIN THE RIP RAP VOIDS AND RESTORATION OF THE RIP RAP STONE TO ORIGINAL LIMITS AND GRADES.
- CORRECTIVE MAINTENANCE:**
IF EROSION OR GULLYING OF THE BASIN SLOPES IS OBSERVED, THE AFFECTED SLOPES SHALL BE PROMPTLY FILLED WITH THE ORIGINAL MATERIAL (OR SUITABLE REPLACEMENT MATERIAL), RE-LOAMED TO ORIGINAL GRADE, RE-SEEDED AND MAINTAINED UNTIL SUCH TIME AS THE AFFECTED AREA HAS SUFFICIENTLY STABILIZED. SUPPLEMENTAL SLOPE STABILIZATION (RIP RAP OR GEOTEXTILE SLOPE REINFORCEMENT) SHALL BE INSTALLED IN LOCATIONS DEMONSTRATING REPETITIVE EROSION OR GULLYING, AND IN SEVERE CASES FLOW REDIRECTION AWAY FROM THE AFFECTED AREA SHALL BE IMPLEMENTED IF NECESSARY.
- ANY BLOCKAGES OF OUTLET DEVICES/STRUCTURES SHALL BE PROMPTLY REMOVED AND THE DEVICE/STRUCTURE CAPACITY RESTORED.
DEFICIENCIES IN ANY STRUCTURAL COMPONENTS OF THE BASIN (INLET & OUTLET STRUCTURES, WEIRS & ORIFICES, WALLS, SPILLWAYS, ETC.) SHALL BE PROMPTLY REPAIRED TO ORIGINAL CONDITION OR REPLACED IN-KIND.
IF SEDIMENT OR ORGANIC DEBRIS BUILD-UP HAS LIMITED THE INFILTRATION CAPABILITIES (INFILTRATION BASINS) TO BELOW THE DESIGN RATE, THE TOP 6 INCHES SHALL BE REMOVED AND THE SURFACE ROTO-TILLED TO A DEPTH OF 12 INCHES. THE BASIN BOTTOM SHOULD BE RESTORED ACCORDING TO ORIGINAL DESIGN SPECIFICATIONS.

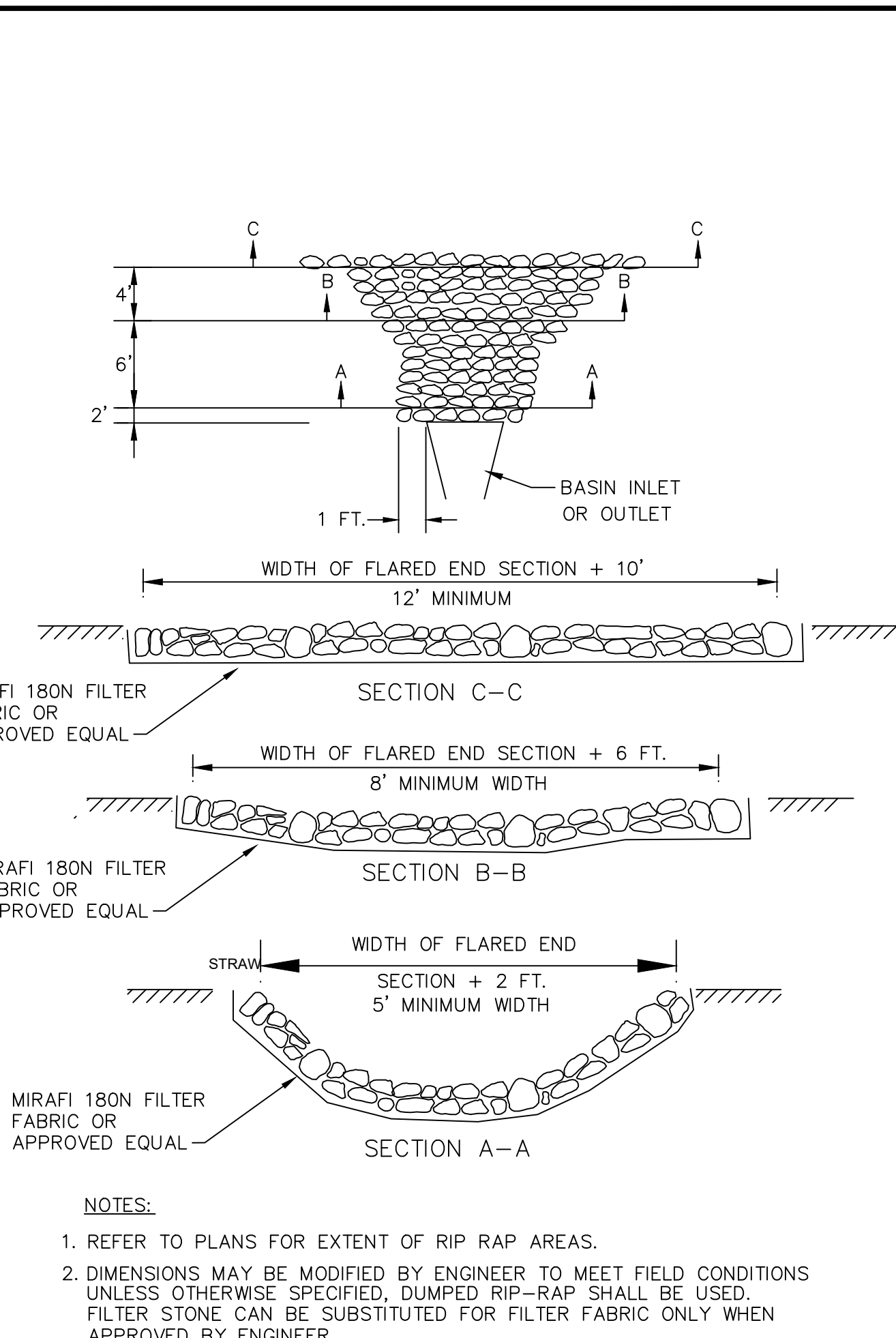

- NOTES:**
- REFER TO PLANS FOR EXTENT OF RIP RAP AREAS.
 - DIMENSIONS MAY BE MODIFIED BY ENGINEER TO MEET FIELD CONDITIONS UNLESS OTHERWISE SPECIFIED. DUMPED RIP-RAP SHALL BE USED. FILTER STONE CAN BE SUBSTITUTED FOR FILTER FABRIC ONLY WHEN APPROVED BY ENGINEER.

ROCK RIP-RAP @ FLARED END OUTLETS
NOT TO SCALE

R-1 RIP RAP:	R-2 RIP RAP:	R-3 RIP RAP:	R-4 RIP RAP:
100% PASS - 2"	100% PASS - 4"	100% PASS - 8"	100% PASS - 14"
0-50% PASS - 1"	0-50% PASS - 2"	0-50% PASS - 4"	0-50% PASS - 4"
0-15% PASS - #4	0-15% PASS - 1"	0-15% PASS - 2"	0-15% PASS - 4"
MIN. DEPTH=4"	MIN. DEPTH=6"	MIN. DEPTH=12"	MIN. DEPTH=21"
BEDDING=FS-1	BEDDING=FS-1	BEDDING=FS-2	BEDDING=FS-3
MIN. DEPTH=3"	MIN. DEPTH=3"	MIN. DEPTH=6"	MIN. DEPTH 9"

ROCK RIP-RAP SPECIFICATIONS ALL LOCATIONS

OWNER:
SHELEEN CLARKE
96 DUCK COVE ROAD
NORTH KINGSTOWN, RI 02852

APPLICANT:
NEW ENGLAND PROPERTIES, LLC
257 WICKFORD CT.
NORTH KINGSTOWN, RI 02852

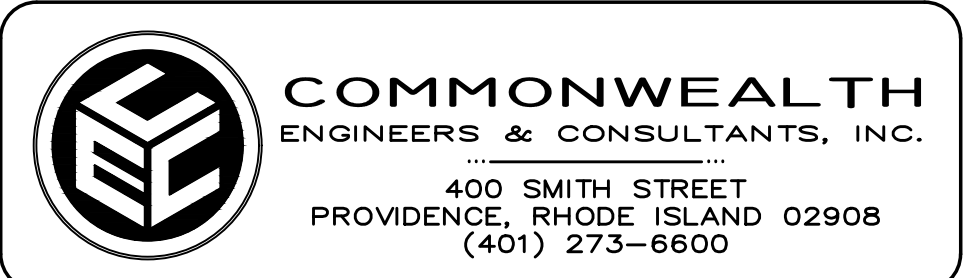
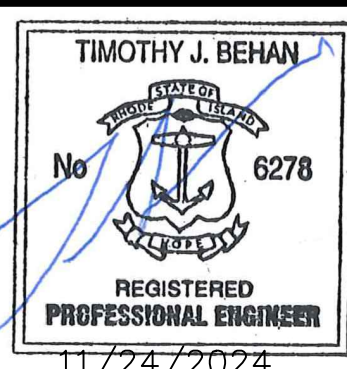

REVISIONS

No.	DATE	DRWN	CHKD
1	4/2/24	TB	TB
2	4/18/24	TB	TB
3	9/6/24	SMA	TB
4	9/30/24	SMA	TB
5	10/21/24	SMA	TB
6	11/24/24	SMA	TB

PERMIT AGENCY REVIEW PLAN
FOR
VILLAGE AT BROAD ROCK
PLAT 33, LOT 24
ON
BROAD ROCK ROAD
SOUTH KINGSTOWN, RHODE ISLAND
CONSTRUCTION DETAILS PLAN-1

SCALE: AS SHOWN	SHEET NO: 12 OF 17	
DRAWN BY: SMA	DESIGN BY: SMA	CHECKED BY: TJB
DATE: FEBRUARY 2024	PROJECT NO: 23011.00	

The following major categories of street classification are established:

a. **Arterial** - A major public street that serves as an avenue for the circulation of traffic into, out of, or around the Town and carries high volumes of traffic and provides for high levels of mobility. See Figure 1.

b. **Collector** - A public street whose principal function is to carry traffic between local streets and arterial streets but that may also provide direct access to abutting properties. These streets provide a balance between land access and mobility. See Figure 2.

c. **Local Public** - Public streets whose primary function is to provide access to abutting residential properties, which are accepted for ownership and maintenance by the public. The following sub-categories of Local Public streets are established:

• **Local Public "A"** - an internal through street providing access to more than 20 lots. See Figure 3.

• **Local Public "B"** - a long permanent dead end or through street providing direct access to 11-20 lots. See Figure 3.

• **Local Public "C"** - a short dead end or through street providing direct access to no more than 10 lots. See Figure 3.

• **Local Public "D"** - a short dead end or through street providing direct access to no more than 5 lots. See Figure 3.

• **Local Public "E"** - optional design for any of the above street categories which provides for drainage swales. See Figure 4.

d. **Local Private** - Privately owned and maintained streets whose primary function is to provide access to abutting residential properties. Streets within residential compounds serving up to twenty (20) residential dwellings and streets in minor residential subdivisions serving up to five (5) residential dwellings on a private street also fall within this classification.

ARTICLE XIII - TABLE 1
GUIDE TO DESIGNING STREETS WITHIN A SUBDIVISION

	Fig. 1 Arterial	Fig. 2 Collector	Fig. 3.4 Local Streets (Public)					Fig. 5a, 5b, 6, 9 Residential Compound (Private)	Fig. 8, 9 Minor Subdivision (Private)
			A	B	C	D	E		
ROW Width	75	60'	50'	40'	40'	40'	40'	40'	40'
Pavement Type	BC	BC	BC	BC	B	B	B	GP	GP
Road Pavement Width	30'	24'	24'	22'	22'	22'	22'	18'	18'
Number Lanes	1-3	1-3	>20	11-20	5-10	1-5	7+	2-20	2-5
Maximum Grades			9%	9%	9%	9%	9%	10%	10%
-centerline			2.5%	4%	6%	1%	2.5%		
-within 150' of centerline intersections									
Minimum Grades								0.5%	0.5%
-centerline	1%	1%	1%	1%	1%	1%	1%	As determined by DPS	As determined by DPS
Minimum Length for Vertical Curves	200'	150'	100'	100'	100'	100'	100'		
Minimum Radius of Centerline Curve	250'	200'	150'	150'	100'	150'	150'	100'	100'

- * Includes Bituminous Curb (See Fig. 3)
- BC Bituminous Concrete (See Fig. 3)
- G Gravel (See Fig. 5a)
- P Paved (See Fig. 5b)
- With further development potential
- With no further development potential

ARTICLE XIII - TABLE 1
GUIDE TO DESIGNING STREETS WITHIN A SUBDIVISION (CONT.)

	Fig. 1 Arterial	Fig. 2 Collector	Fig. 3.4 Local Streets (Public)					Fig. 5a, 5b, 6, 9 Residential Compound (Private)	Fig. 8, 9 Minor Subdivision (Private)
			A	B	C	D	E		
Minimum Sight Distance	200'	250'	100'	100'	100'	100'	100'	100'	100'
Cul-de-sac Turnaround**	100'	100'	100'	100'	100'	100'	100'	100'	100'
-ROW Diameter	80'	80'	80'	80'	80'	80'	80'	80'	80'
-Pavement Diameter	80'	80'	80'	80'	80'	80'	80'	80'	80'
-Maximum Grades	4.5%	4.5%	4.5%	4.5%	4.5%	4.5%	4.5%	N/A	N/A
-Minimum Grades	2%	2%	2%	2%	2%	2%	2%	N/A	N/A
Intersection Fillet Curve									
-Minimum ROW Radius	25'	25'	15'	15'	15'	15'	15'	15'	15-15'
-Minimum Pavement Radius	30'	30'	25'	25'	25'	25'	25'	25'	25'
Pavement Crown	7"	6"	6"	6"	6"	6"	6"	4"	4"

- * Includes Bituminous Curb (See Fig. 3)
- ** See Fig. 8 for Hammerhead Turnaround (Optional)
- BC Bituminous Concrete (See Fig. 3)
- D Gravel (See Fig. 5a)
- P Paved (See Fig. 5b)

PROPOSED PRIVATE STREET CRITERIA/DETAILS

SCALE: AS SHOWN

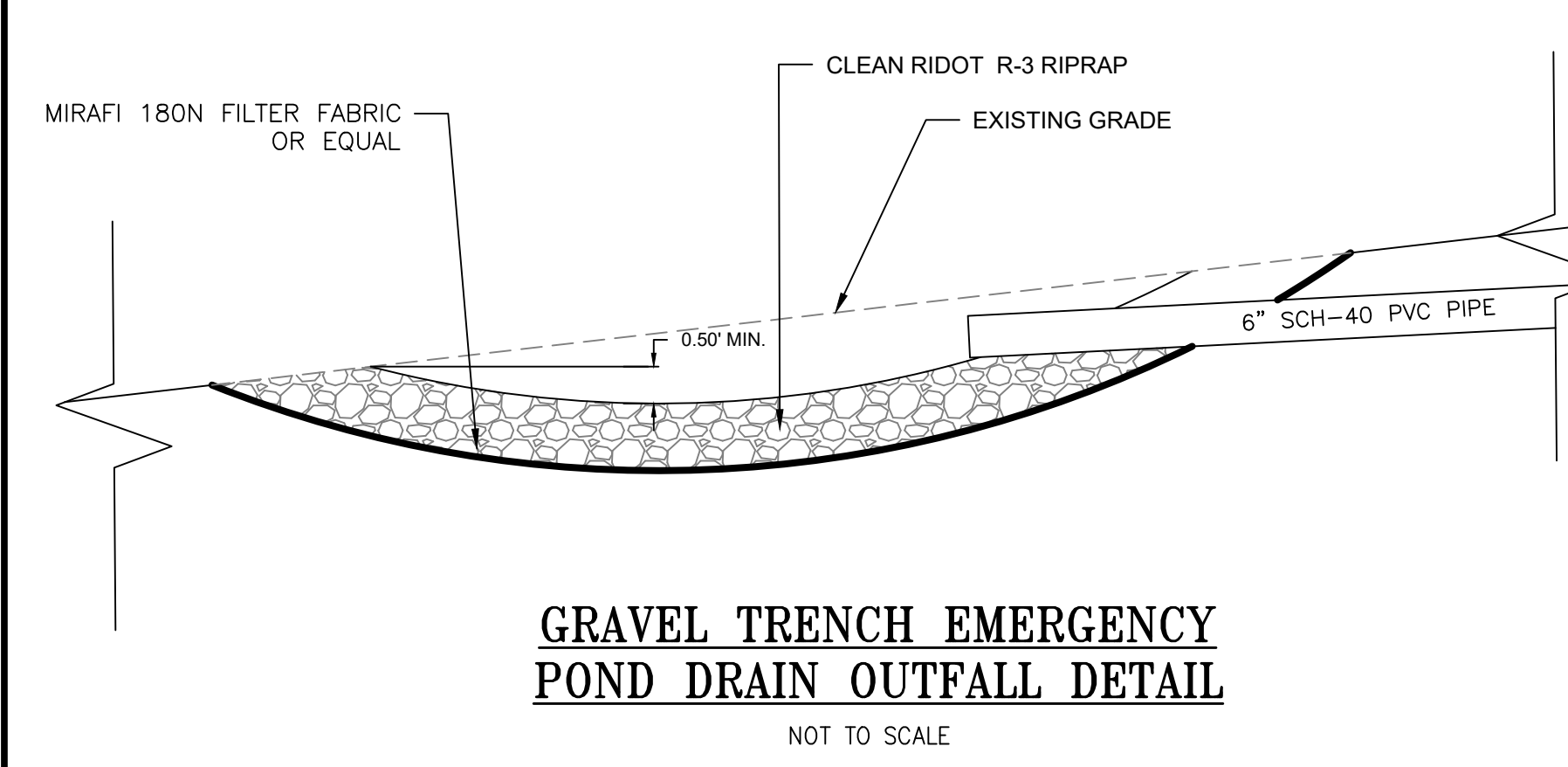
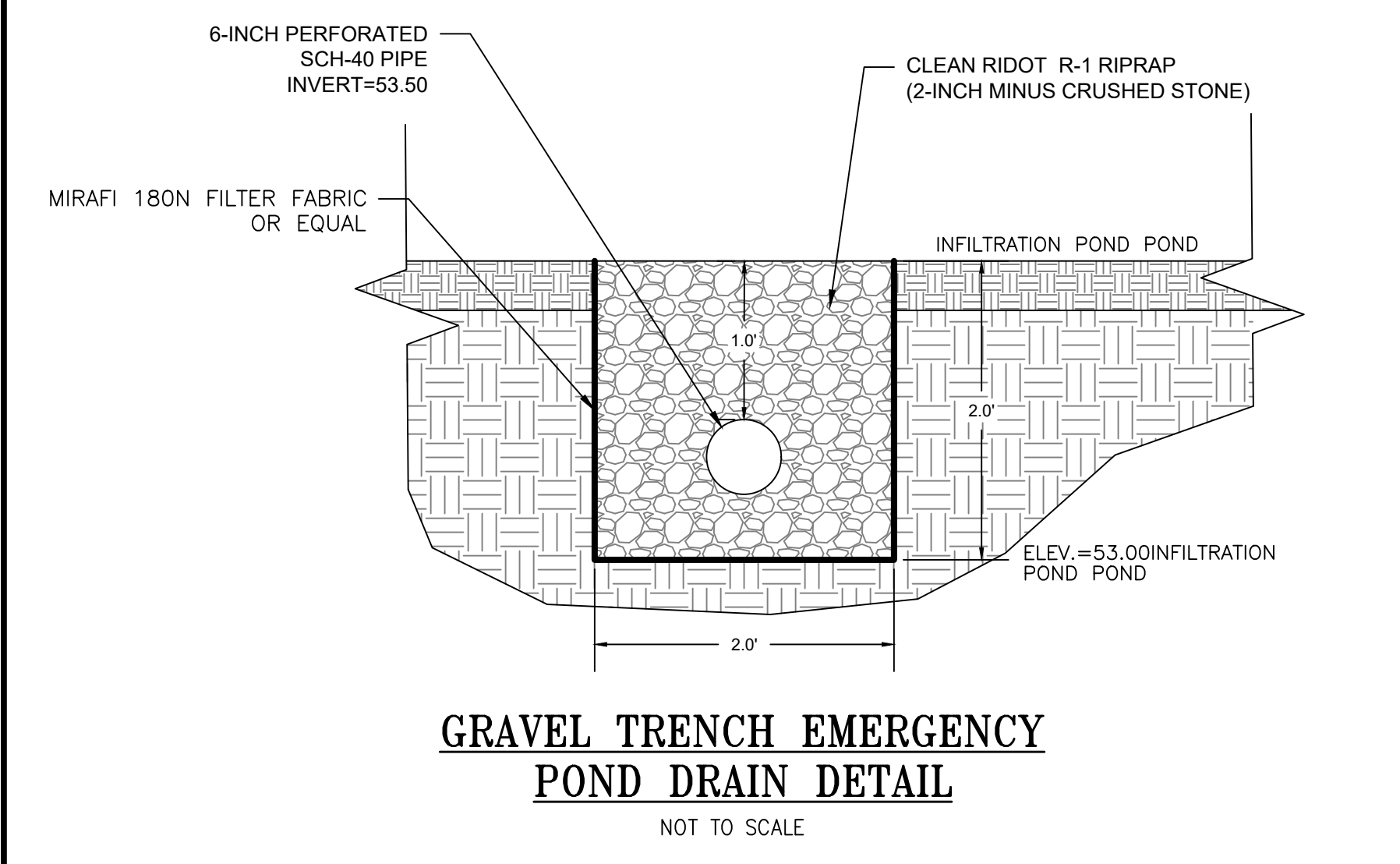
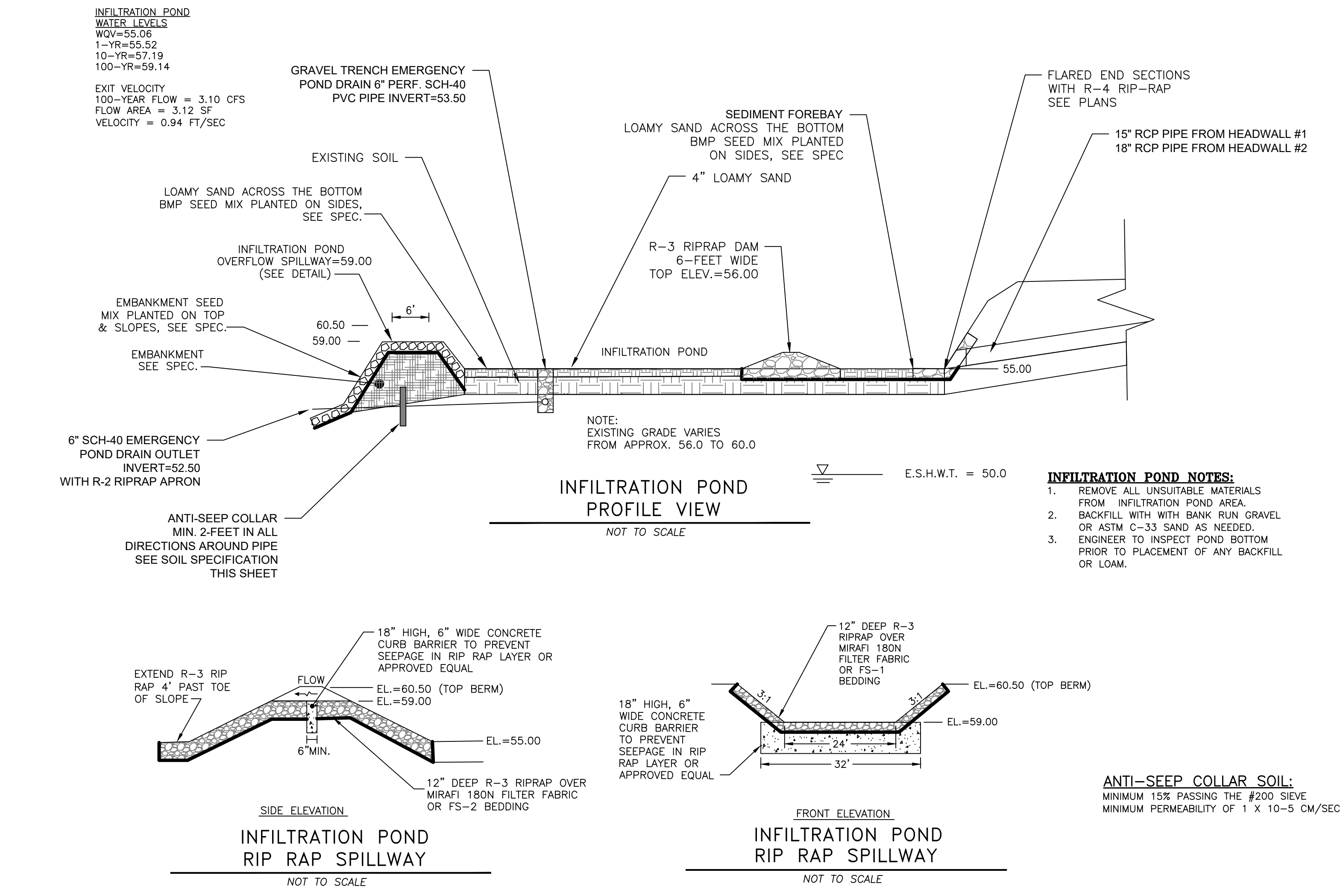
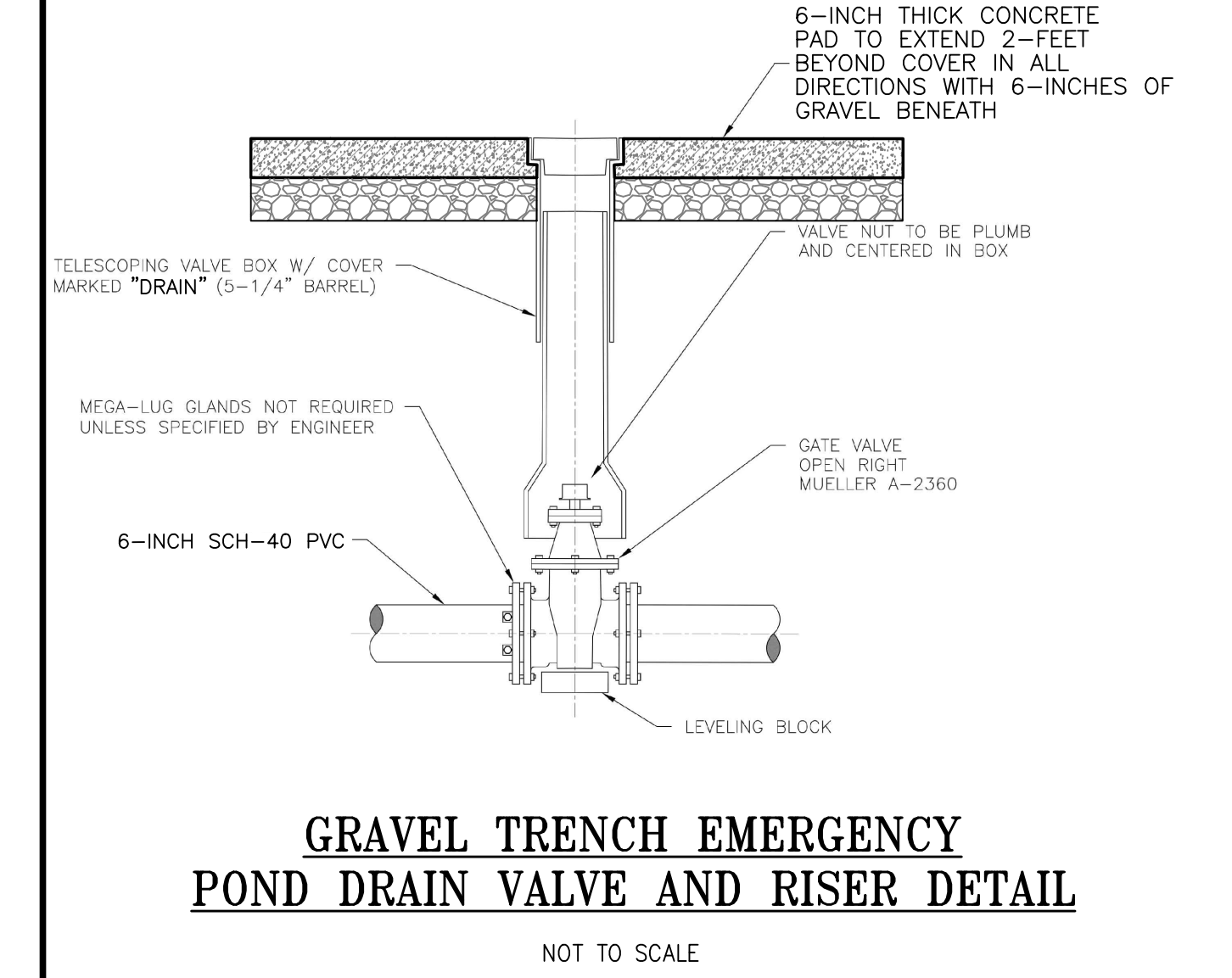
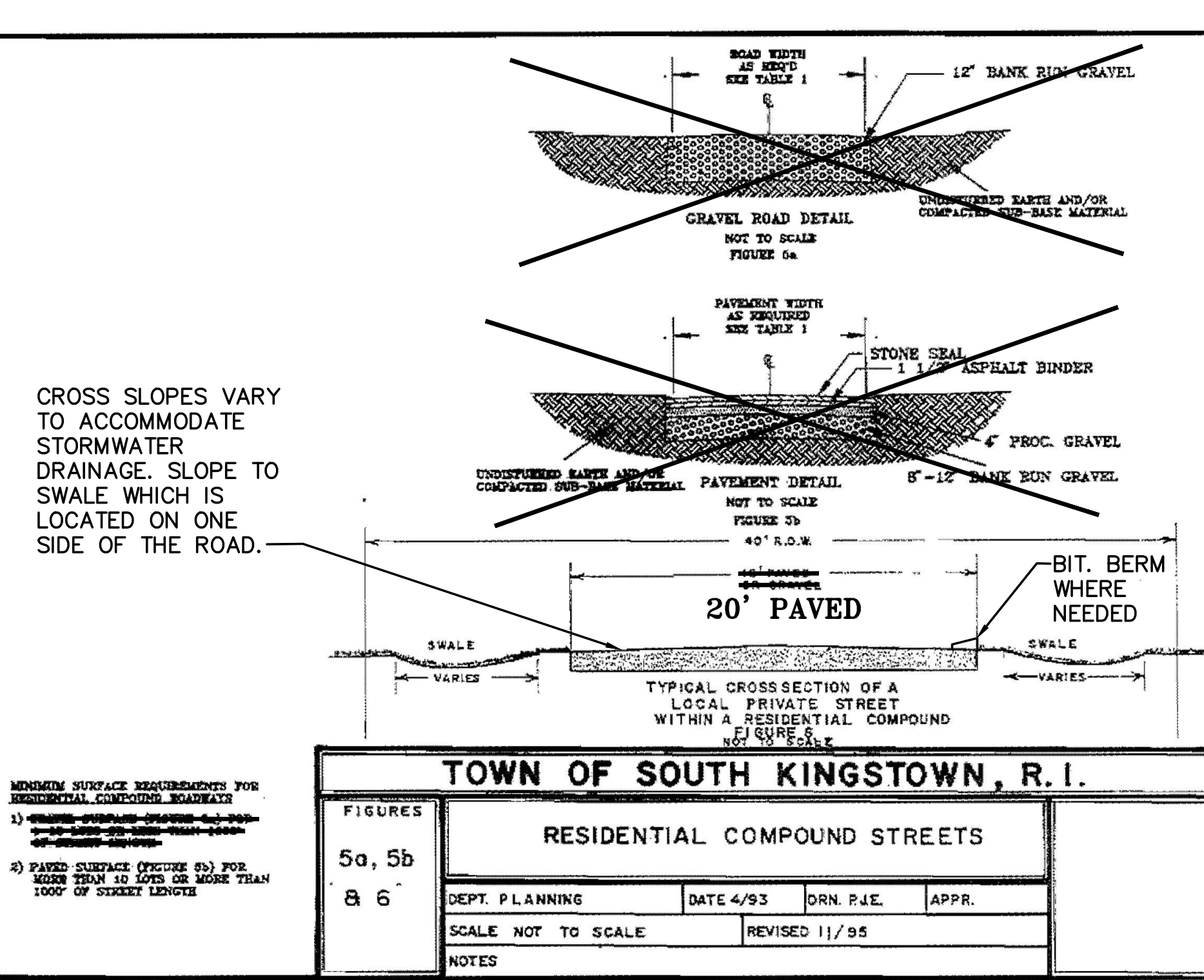

FILTER FABRIC SPEC.:
SHALL MEET THE FOLLOWING:
THICKNESS=0.08"
OPENING SIZE=#80 SIEVE
FLOW RATE=125 GAL/MIN.
ASTM D751=125 LB.
ASTM D117=400 PSI.
ASTM D1682=300 LB.

EMBANKMENT SEED MIX:
RED FESCUE @ 1.75 LBS/1,000SF
COLONIAL BENTGRASS, "EXETER" @ 0.11 LBS/1,000SF
PERENNIAL RYEGRASS @ 0.11 LBS/1,000SF
BIRDSFOOT TREFOLI*, "EMPIRE" @ 0.35 LBS/1,000SF
* USE INOCULATED SEED

BMP SEED MIX:
CREEP, RED FESCUE @ 0.45 LBS/1,000SF
TALL FESCUE @ 0.45 LBS/1,000SF

EMBANKMENT MATERIAL:
IMPERVIOUS MATERIAL (UNIFIED SOIL CLASSIFICATION GC, SC, CH OR CL AND AT LEAST 30% PASSING 200 SIEVE) COMPACTED TO 95% AT ALL EMBANKMENT AREAS WHICH HIGHER THAN SURROUNDING GRADES. MATERIAL SHALL BE FREE OF ROOTS, STUMPS, WOOD, RUBBISH, STONES GREATER THAN 6", FROZEN OR OTHER OBJECTIONABLE MATERIALS.

BANK RUN GRAVEL SPEC.:
GRAVEL SHALL NOT CONTAIN ANY MATERIAL LARGER THAN 3". UP TO 10% MAY BE SIZED BETWEEN 3/4" AND 3". GRAVEL SHALL MEET THE FOLLOWING:
SIEVE SIZE % PASSING
#4 100%
#4 55%-100%
#10 40%-100%
#40 10%-50%
#100 0%-20%
#200 0%-2%

TOPSOIL SPEC.:
TOPSOIL SHALL HAVE A TEXTURE CLASSIFICATION OF SANDY LOAM AND BE FREE OF ROCKS GREATER THAN 3/4", ROOTS, DEBRIS AND ANY UNDESIRABLE MATERIALS AS DETERMINED BY THE TOWN OR ENGINEER. TOPSOIL SHALL ALSO MEET ROOT SPECIFICATIONS AND HAVE A PERCOLATION RATE OF 10 MINUTES PER INCH OR FASTER.
ASTM C-33 SAND SPEC. ASTM C-33 SAND SHALL MEET ASTM C-33 REQUIREMENTS AND ALSO THE FOLLOWING:
SIZE=0.02" TO 0.04"
% PASS 200 SIEVE < 1.0%

OWNER:
SHELEEN CLARKE
96 DUCK COVE ROAD
NORTH KINGSTOWN, RI 02852

APPLICANT:
NEW ENGLAND PROPERTIES, LLC
257 WICKFORD CT.
NORTH KINGSTOWN, RI 02852

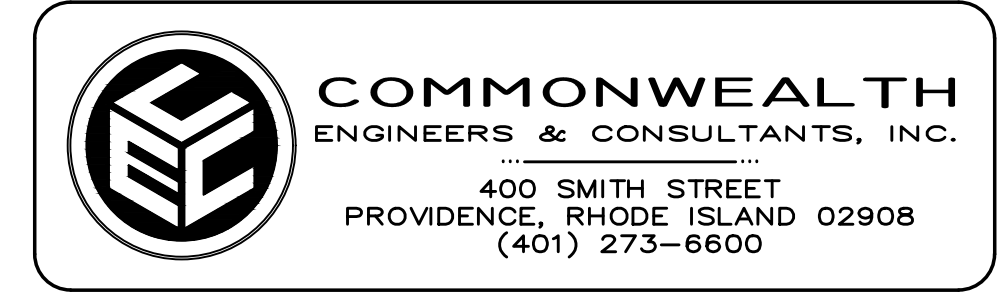
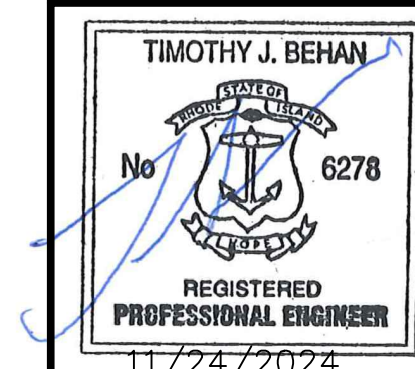

REVISIONS

No.	DATE	DRWN	CHKD
1	4/2/24	TB	TB
2	4/18/24	TB	TB
3	9/6/24	SMA	TB
4	9/30/24	SMA	TB
5	10/21/24	SMA	TB
6	11/24/24	SMA	TB

PERMIT AGENCY REVIEW PLAN
FOR
VILLAGE AT BROAD ROCK
PLAT 33, LOT 24
ON
BROAD ROCK ROAD
SOUTH KINGSTOWN, RHODE ISLAND
CONSTRUCTION DETAILS PLAN-2

SCALE: AS SHOWN SHEET NO: 13 OF 17
DRAWN BY: SMA DESIGN BY: SMA CHECKED BY: TJB
DATE: FEBRUARY 2024 PROJECT NO: 23011.00

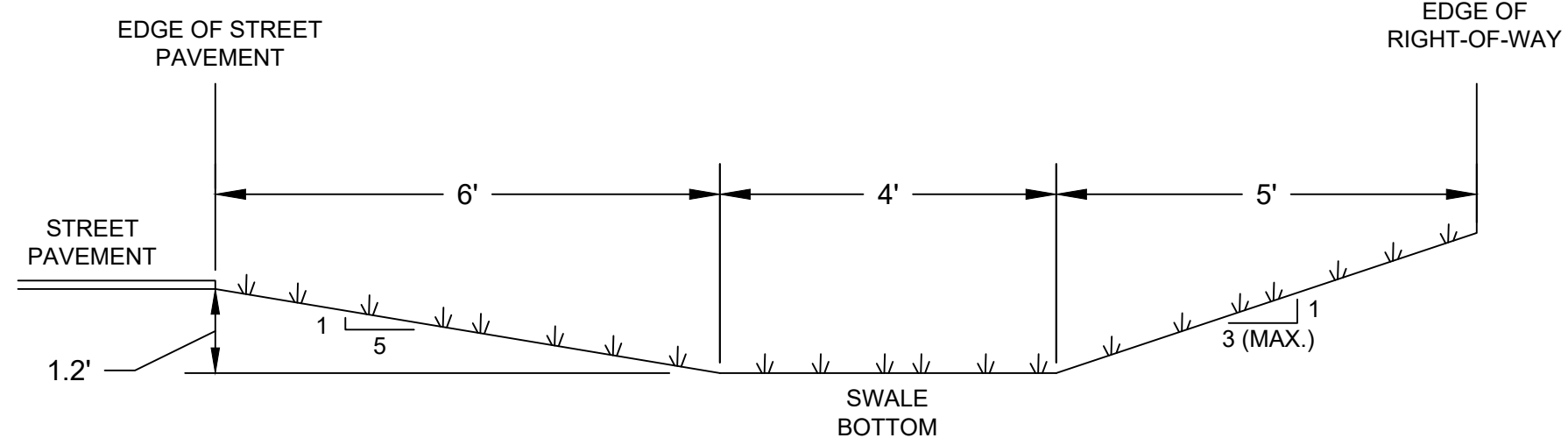

SECTION WITH NO DRIVEWAY

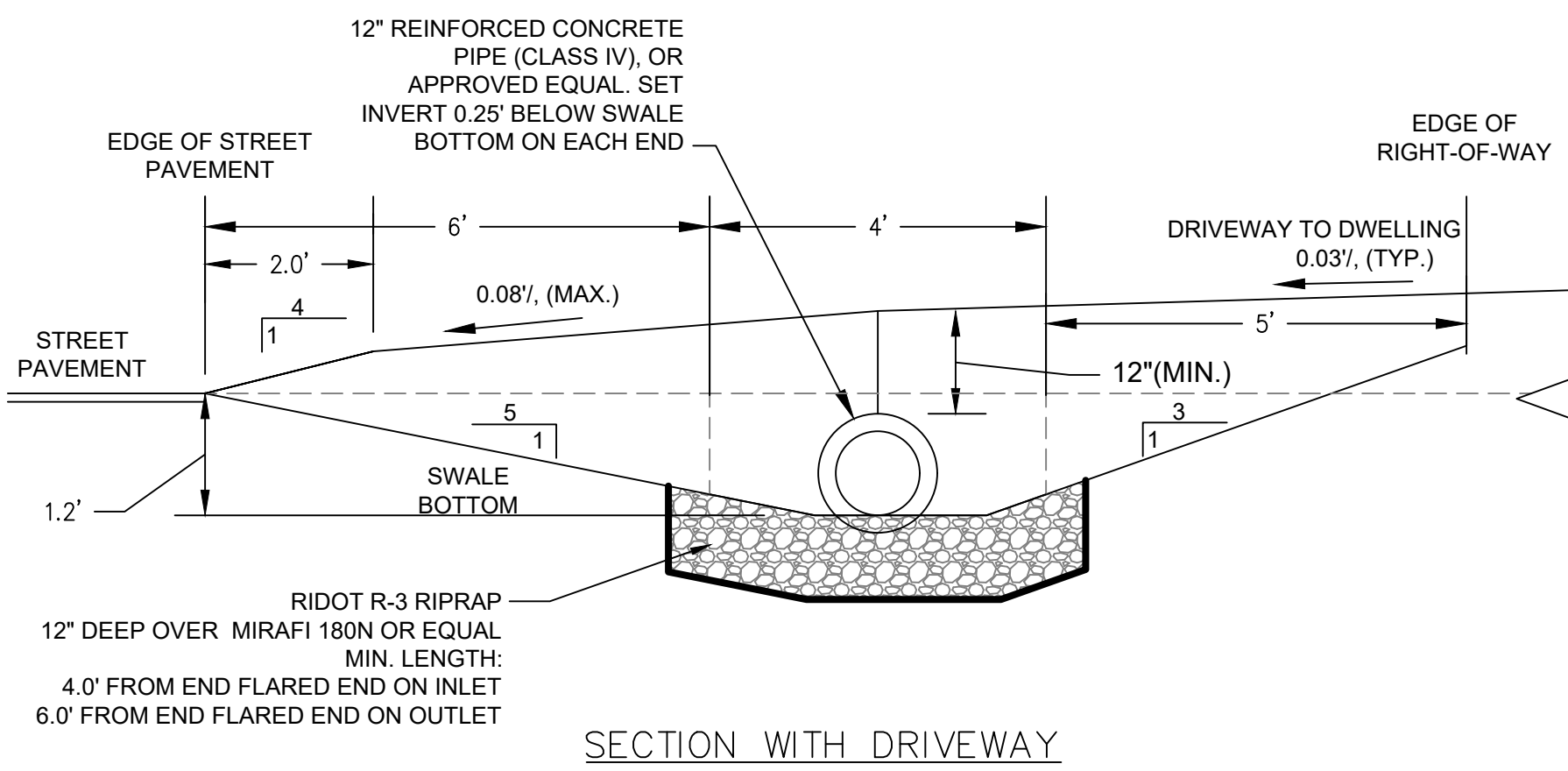

SECTION WITH DRIVEWAY

NOTE: REINFORCED CONCRETE PIPE INSTALLED IN ACCORDANCE WITH MANUFACTURERS RECOMMENDATIONS AND BEDDING REQUIREMENTS

GRASSED SWALE TYPICAL DIMENSIONS

SCALE: NOT TO SCALE

GRASS SWALE DATA:
MAXIMUM SLOPE = 0.04% (4%)
(CHECK DAMS NOT INCLUDED IN CALCULATIONS)

STORM	PEAK FLOW	MAX. DEPTH	MAX. VELOCITY
WQV	0.43 CFS	0.06 FT.	1.59 FT/SEC
1-YR	0.98 CFS	0.10 FT.	2.14 FT/SEC
10-YR	3.76 CFS	0.22 FT.	3.54 FT/SEC
100-YR	9.62 CFS	0.38 FT.	4.85 FT/SEC

* MIN. CHANNEL CAPACITY AT 1.2' DEEP = 91.17 CFS
**VALUES SHOWN ARE THE GREATER OF EITHER SWALE AS CALCULATED BY HYDROCAD MODEL

- NOTE:
- REFER TO PLAN FOR GRASS SWALE LOCATION.
 - CHECK DAMS TO BE INSTALLED AS SHOWN.
 - CHECK DAMS SHALL BE MIN. 0.5-FOOT HIGH, 3-FOOT WIDE AT THE BASE AND EXTEND ACROSS THE WIDTH OF THE SWALE.
 - CHECK DAMS TO BE CONSTRUCTED OF RIDOT R-2 RIPRAP OVER MIRAFI 180N FILTER FABRIC OR FS-1 FILTER STONE

DRIVEWAY AND CULVERT ELEVATION SUMMARY							
LOT NO.	EDGE OF ROADWAY ELEV. INLET/OUTLET (FT.)	INLET INV. (FT.)	OUTLET INV. (FT.)	INLET TOP CULVERT ELEV. (FT.)	OUTLET TOP CULVERT ELEV. (FT.)	DRIVEWAY AT INLET OF CULVERT MIN. ELEV. (FT.)	DRIVEWAY AT OUTLET OF CULVERT MIN. ELEV. (FT.)
1	81.35/81.15	80.21	79.77	81.42	80.98	82.36	82.04
2	80.30/80.00	78.89	78.45	80.10	79.66	81.04	80.72
3	78.90/78.32	77.66	76.71	78.87	77.92	79.63	79.16
4	74.23/73.27	73.15	71.80	74.36	73.01	75.12	74.25
5	71.78/70.82	70.75	69.30	71.96	70.51	72.72	71.75
6	63.86/63.42	62.61	61.90	63.82	63.11	64.64	64.29
7	67.95/67.1	66.75	65.45	67.96	66.66	68.78	67.84

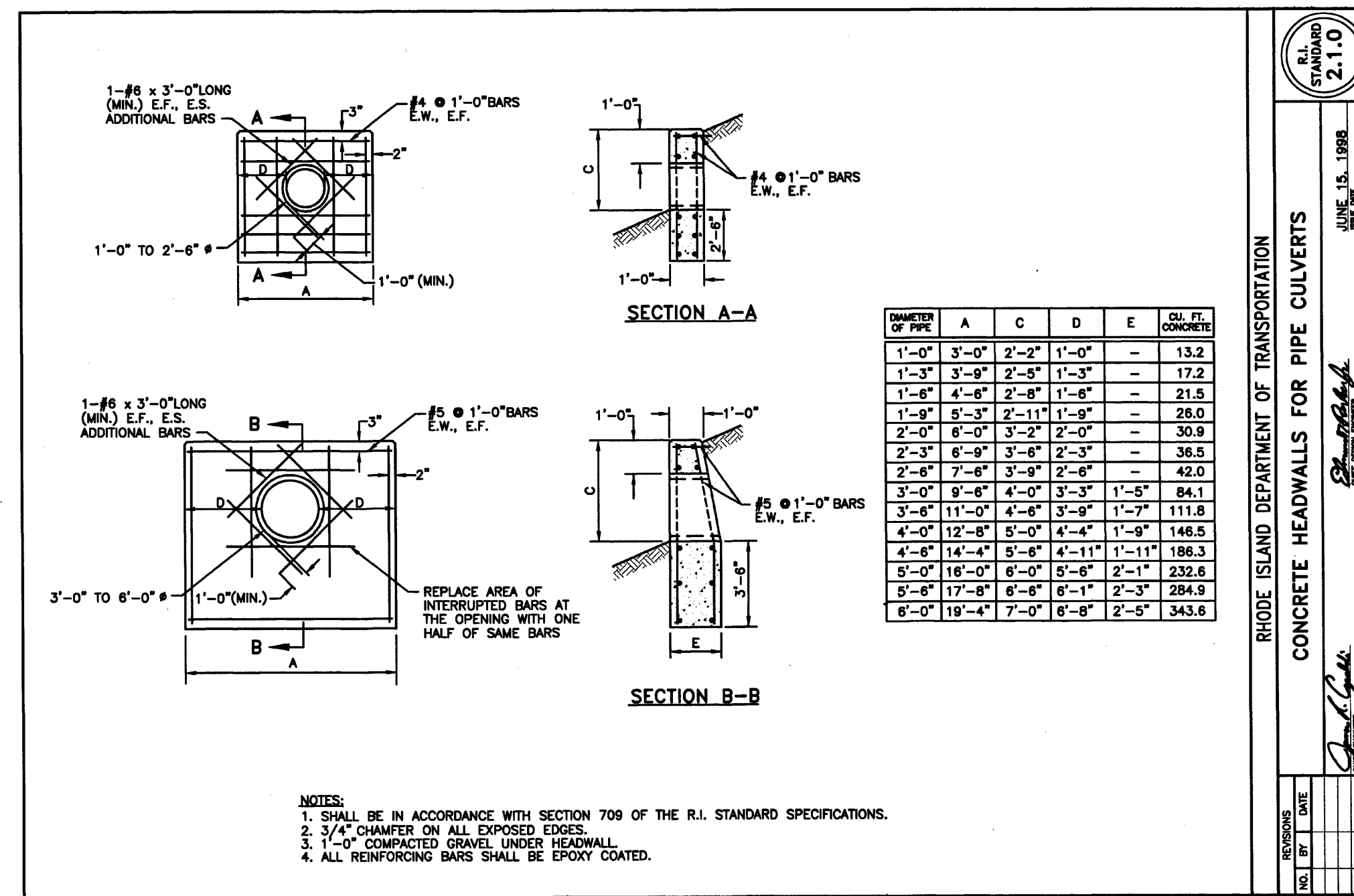

FILTER FABRIC SPEC.:
SHALL MEET THE FOLLOWING:

THICKNESS=0.08"
OPENING SIZE=#80 SIEVE
FLOW RATE=125 GAL/MIN.
ASTM D751=125 LB.
ASTM D1117=400 PSI.
ASTM D1682=300 LB.

EMBANKMENT MATERIAL:
IMPERVIOUS MATERIAL (UNIFIED SOIL CLASSIFICATION GC, SC, CH OR CL AND AT LEAST 30% PASSING 200 SIEVE) COMPACTED TO 95% AT ALL EMBANKMENT AREAS WHICH HIGHER THAN SURROUNDING GRADES. MATERIAL SHALL BE FREE OF ROOTS, STUMPS, WOOD, RUBBISH, STONES GREATER THAN 6". FROZEN OR OTHER OBJECTIONABLE MATERIALS.

TOPSOIL SPEC.:
TOPSOIL SHALL HAVE A TEXTURE CLASSIFICATION OF SANDY LOAM AND BE FREE OF ROCKS GREATER THAN 3/4", ROOTS, DEBRIS AND ANY UNDESIRABLE MATERIALS AS DETERMINED BY THE TOWN OR ENGINEER. TOPSOIL SHALL ALSO MEET RIDOT SPECIFICATIONS AND HAVE A PERCOLATION RATE OF 10 MINUTES PER INCH OR FASTER.

EMBANKMENT SEED MIX:

RED FESCUE @ 1.75 LBS/1,000SF
COLONIAL BENTGRASS, 'EXETER' @ 0.11 LBS/1,000SF
PERENNIAL RYEGRASS @ 0.11 LBS/1,000SF
BIRDSFOOT TREFOLI*, 'EMPIRE' @ 0.35 LBS/1,000SF

BMP SEED MIX:
CREEP, RED FESCUE @ 0.45 LBS/1,000SF
TALL FESCUE @ 0.45 LBS/1,000SF

BANK RUN GRAVEL SPEC.:
GRAVEL SHALL NOT CONTAIN ANY MATERIAL LARGER THAN 3" UP TO 10% MAY BE SIZED BETWEEN 3/4" AND 3". GRAVEL SHALL MEET THE FOLLOWING:

SIEVE SIZE	% PASSING
3/4"	100%
#4	55%-100%
#10	40%-100%
#40	10%-50%
#100	0%-20%
#200	0%-2%

ASTM C-33 SAND SPEC.:
ASTM C-33 SAND SHALL MEET ASTM C-33 REQUIREMENTS AND ALSO THE FOLLOWING:

SIZE	% PASS
0.075"	100%
0.15"	100%
0.3"	100%
0.6"	100%
1.18"	100%
2.0"	100%
4.75"	100%
9.5"	100%
19.0"	100%
37.5"	100%
75.0"	100%
150.0"	100%
300.0"	100%
600.0"	100%
1200.0"	100%
2400.0"	100%
4800.0"	100%
9600.0"	100%
19200.0"	100%
38400.0"	100%
76800.0"	100%
153600.0"	100%
307200.0"	100%
614400.0"	100%
1228800.0"	100%
2457600.0"	100%
4915200.0"	100%
9830400.0"	100%
19660800.0"	100%
39321600.0"	100%
78643200.0"	100%
157286400.0"	100%
314572800.0"	100%
629145600.0"	100%
1258291200.0"	100%
2516582400.0"	100%
5033164800.0"	100%
10066329600.0"	100%
20132659200.0"	100%
40265318400.0"	100%
80530636800.0"	100%
161061273600.0"	100%
322122547200.0"	100%
644245094400.0"	100%
1288490188800.0"	100%
2576980377600.0"	100%
5153960755200.0"	100%
10307921510400.0"	100%
20615843020800.0"	100%
41231686041600.0"	100%
82463372083200.0"	100%
164926744166400.0"	100%
329853488332800.0"	100%
659706976665600.0"	100%
1319413953331200.0"	100%
2638827906662400.0"	100%
5277655813324800.0"	100%
10555311626649600.0"	100%
21110623253299200.0"	100%
42221246506598400.0"	100%
84442493013196800.0"	100%
168884986026393600.0"	100%
337769972052787200.0"	100%
675539944105574400.0"	100%
1351079888211148800.0"	100%
2702159776422297600.0"	100%
5404319552844595200.0"	100%
10808639105689184000.0"	100%
21617278211378368000.0"	100%
43234556422756736000.0"	100%
86469112845513472000.0"	100%
172938225691026944000.0"	100%
345876451382053888000.0"	100%
691752902764107776000.0"	100%
1383505805528215552000.0"	100%
2767011611056431104000.0"	100%
5534023222112862208000.0"	100%
11068046444225724416000.0"	100%
22136092888451448832000.0"	100%
44272185776902897664000.0"	100%
88544371553805795328000.0"	100%
177088743107611590656000.0"	100%
354177486215223181312000.0"	100%
708354972430446362624000.0"	100%
1416709944860892725248000.0"	100%
2833419889721785450496000.0"	100%
5666839779443570900992000.0"	100%
11333679558887141801984000.0"	100%
22667359117774283603968000.0"	100%
45334718235548567207936000.0"	100%
90669436471097134415872000.0"	100%
181338872942194268831744000.0"	100%
362677745884388537663488000.0"	100%
725355491768777075326976000.0"	100%
1450710923537554150653952000.0"	100%
2901421847075108301307904000.0"	100%
5802843694150216602615808000.0"	100%
11605687388300432205231616000.0"	100%
23211374776600864410462232000.0"	100%
46422749553201728820924464000.0"	100%
92845499106403457641848928000.0"	100%
18569099821280691528373776000.0"	100%
37138199642561383056747552000.0"	100%
74276399285122766113495104000.0"	100%
148552798570245532226990208000.0"	100%
297105597140491064453980416000.0"	100%
594211194280982128907960832000.0"	100%
1188422388561964257815921664000.0"	100%
2376844777123928515631943328000.0"	100%
4753689554247857031263886656000.0"	100%
9507379108495714062527773312000.0"	100%
19014758216991428125055546624000.0"	100%
38029516433982856250111093248000.0"	100%
76059032867965712500222186496000.0"	100%
152118065735931425000444929984000.0"	100%
304236131471862850000889859968000.0"	100%
608472262943725700001779719937984000.0"	100%
12169445258874514000035594398759776000.0"	100%
24338890517749028000071188797555552000.0"	100%
486777810354980560000143777595111104000.0"	100%
9735556207099611200002875551902222208000.0"	100%
19471112414199224000057511044044444448000.0"	100%
38942224828398448000115022088888888896000.0"	100%
77884449656796896000230044177777777792000.0"	100%
155768899313593792000460088355555555584000.0"	100%
31153779862718758400092017671111111168000.0"	100%
623075597254375168000184035342222222336000.0"	100%
124615119450875033600036807068444444672000.0"	100%
2492302389017500672000736141368888881344000.0"	100%
49846047780350013440001472282737777772688000.0"	100%
9969209556070002688000294456547555555553376000.0"	100%
1993841911214000537600058891311111111116752000.0"	100%
39876838224280001075200011778262222222233504000.0"	100%
7975367644856000215040002357652444444467008000.0"	100%
159507352937120004300800047153048888888134016000.0"	100%
319014705874240008601600094306097777777268032000.0"	100%
6380294117484800017203200018861219555555555336064000.0"	100%
1276058823496960003440640003772243911111111672128000.0"	100%
2552117646993920006881280007544487822222223344512000.0"	100%
5104235293987840001376256000150889764444446688032000.0"	100%
102084705879756800027525120003017795288888813376064000.0"	100%
204169411759513600055050240006035590577777726752128000.0"	100%
40833882351902720001101004800012071181155555555533504256000.0"	100%
81667764703805440002202009600024142363111111167008512000.0"	100%
163335529407610880004404019200048284726222222334016256000.0"	100%
32667105881522176000880803840009656945244444668032000.0"	100%
65334211763044352000176160768000193138904888881336064000.0"	100%
13066842352608870400035232153600038627780977777267128000.0"	100%
2613368470521774080007046430720007725556195555555334256000.0"	100%
5226736941043548160001409286144000154511131111167008512000.0"	100%
10453473882087096320002818561280003090222631111167008512000.0"	100%
2090694776417391264000563712256000618044524444668032000.0"	100%
41813895528347825280001127424512000123608904888881336064000.0"	100%
8362779105669565056000225484810240002472178097777267128000.0"	100%
167255582133391301120004509696204800049443631111167008512000.0"	100%
334511164266782602240009019392409600098886663111167008512000.0"	100%
6690223285335652044800018038784192000197773263111167008512000.0"	100%
1338044656667130489600036077568384000395546524444668032000.0"	100%
267608931333426097920007215513676800079109304888881336064000.0"	100%
53521786266685219584000144310273536000158218609777267128000.0"	100%
1070435725333704391680002886205470720003164372111167008512000.0"	100%
2140871450667408783360005772410841440006328744311167008512000.0"	100%
4281742901334817566720	

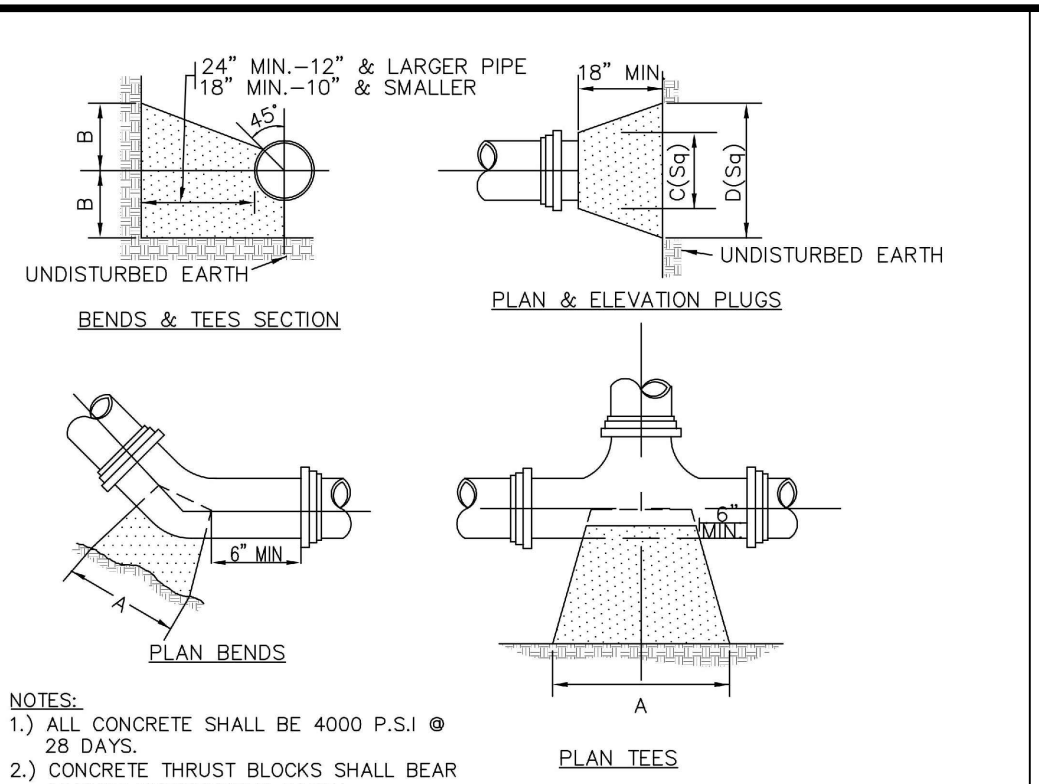
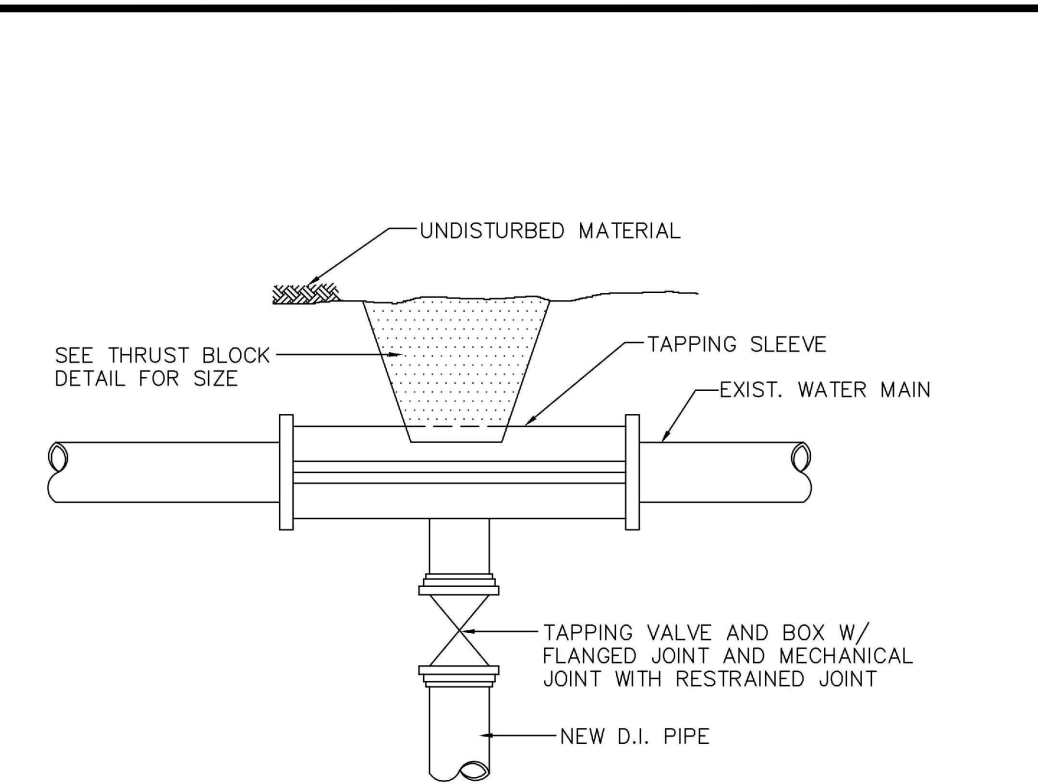
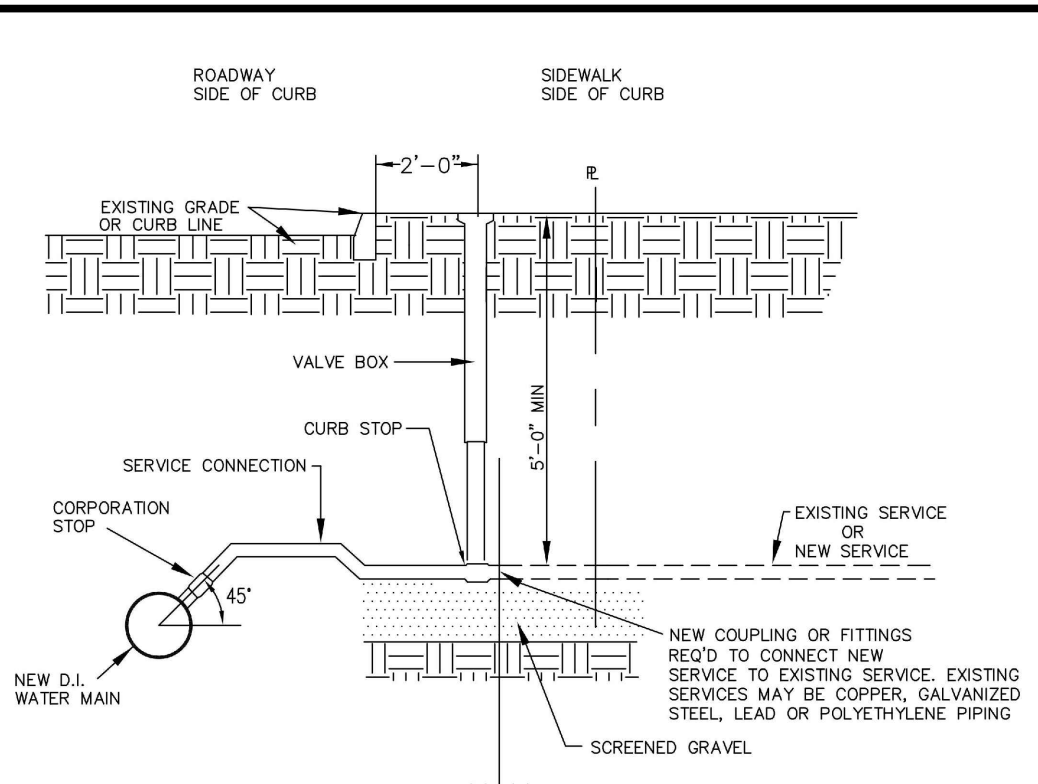
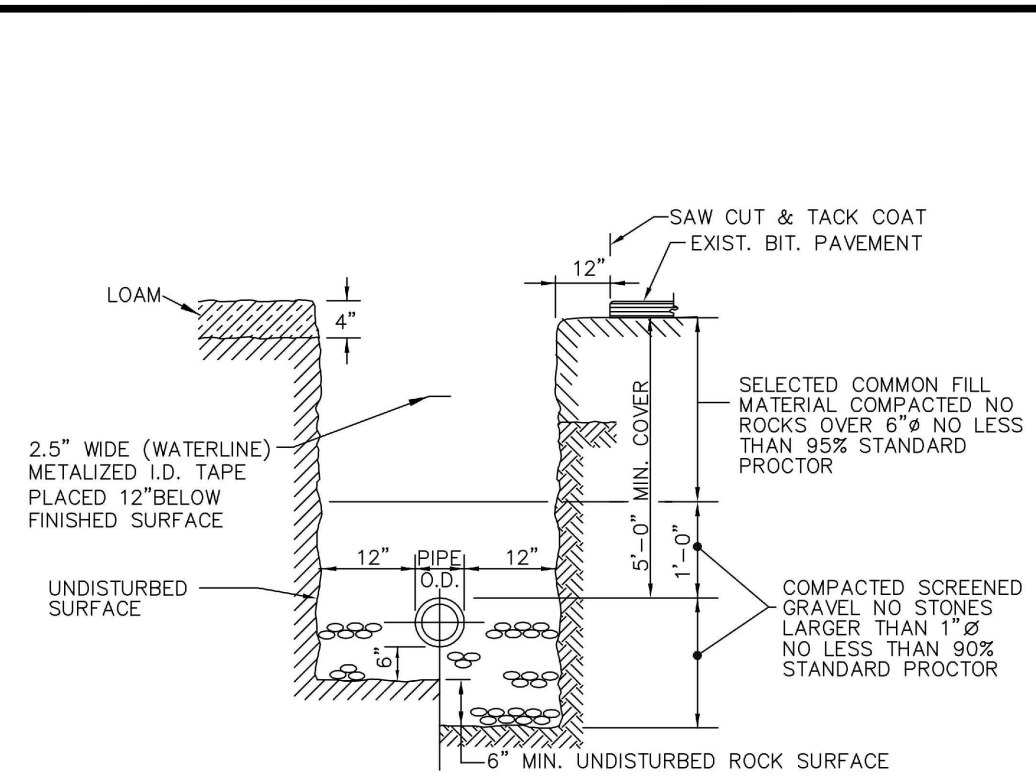
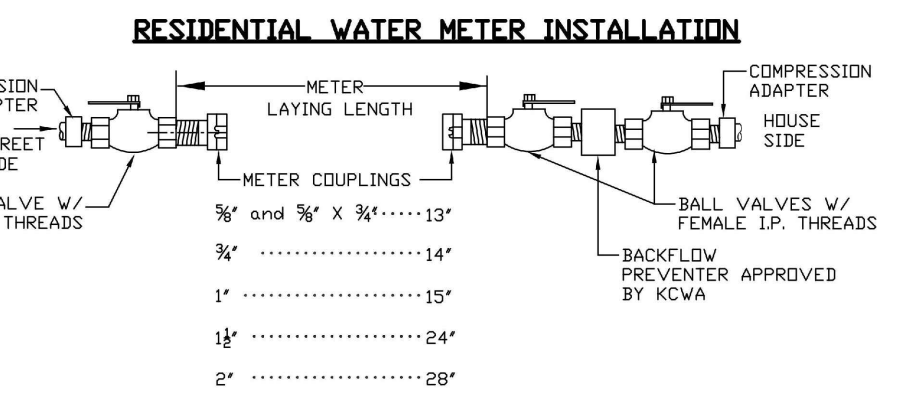
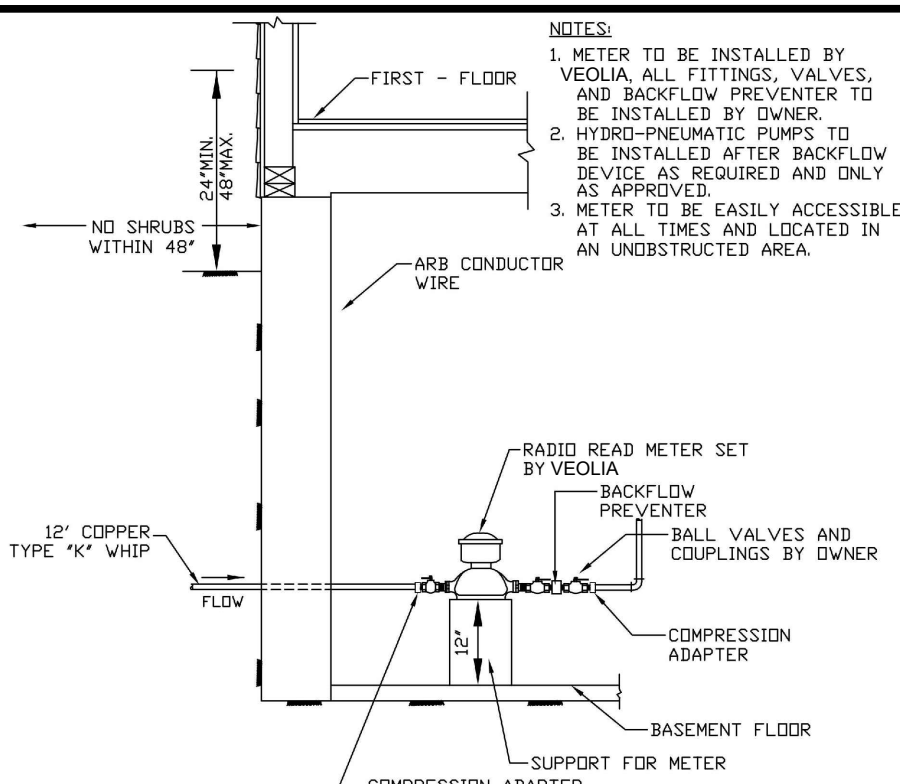

SIZE	TEES	PLUGS	90° BEND	45° BEND	22½ BEND	1½ BEND			
A	B	C	D	A	B	A	B		
6"	20"	10"	21"	24"	12"	5"	13"	9"	5"
8"	26"	13"	26"	32"	16"	24"	12"	17"	8"
10"	34"	17"	34"	42"	20"	30"	15"	22"	11"
12"	41"	20"	41"	48"	24"	35"	18"	25"	13"
16"	54"	27"	54"	64"	32"	47"	23"	34"	17"

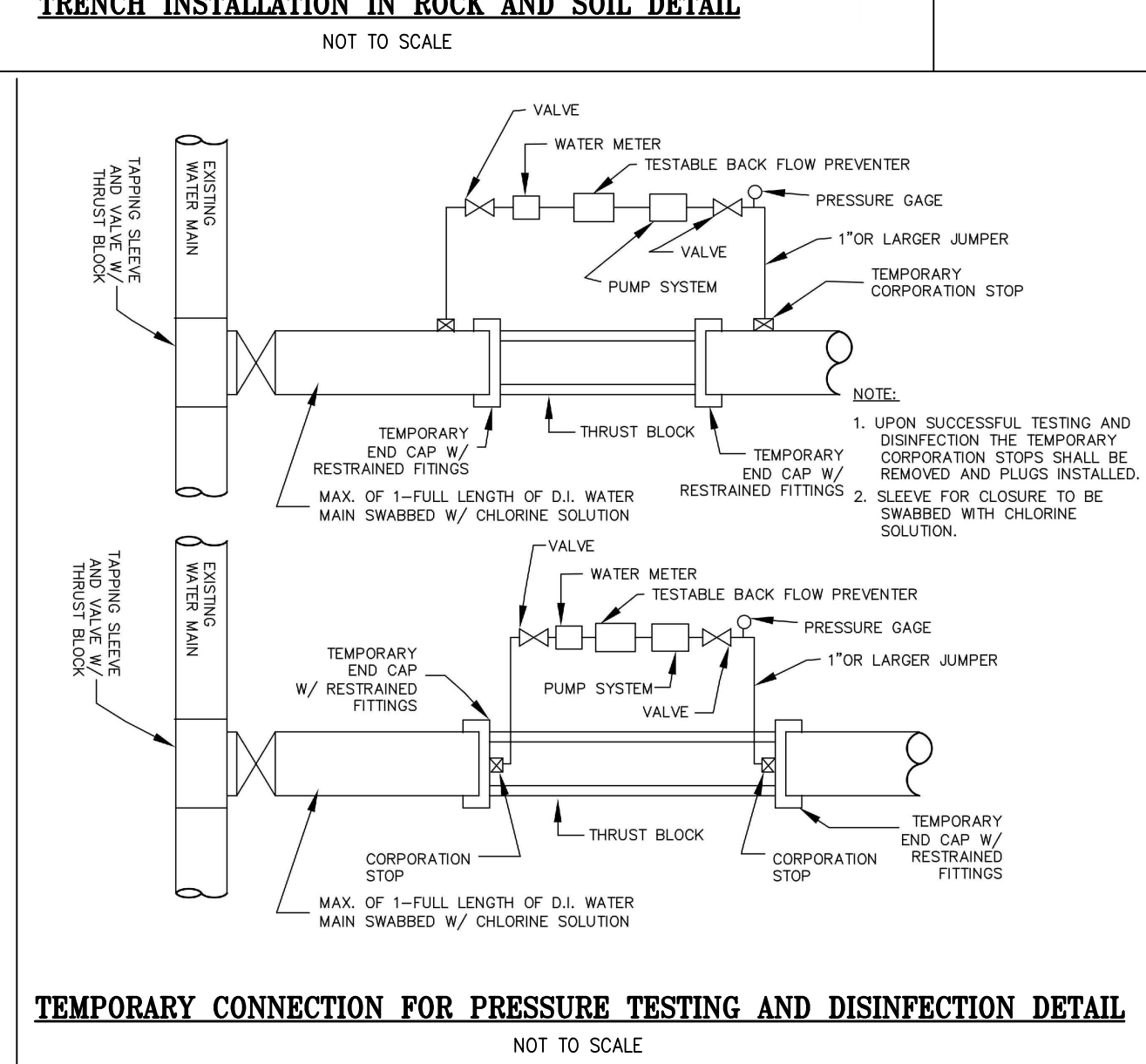
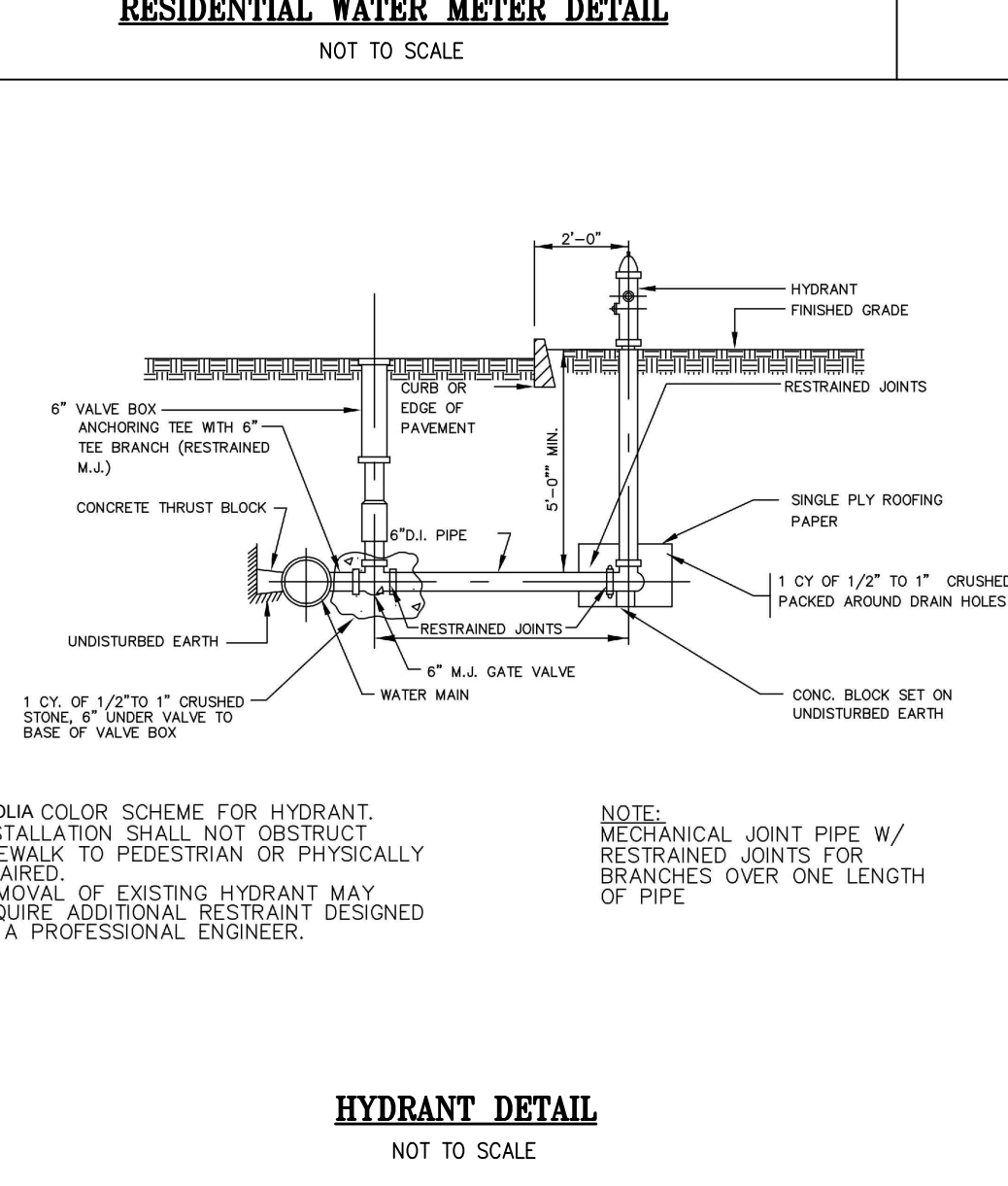

RESTRAINED PIPE LENGTHS FOR RESTRAINED FITTINGS

FITTING	RESTRAINED LENGTH
12" PLUG	94"
12" TEE	44"
12" 90°	58"
12" 45°	44"
12" 22 1/2°	22"
12" 11 1/4°	22"
8" PLUG	58"
8" TEE	44"
8" 90°	44"
8" 45°	22"
8" 22 1/2°	22"
8" 11 1/4°	22"
8" X 6"	44"
6" PLUG	44"
6" TEE	22"
6" 90°	22"
6" 45°	22"
6" 22 1/2°	22"
6" 11 1/4°	22"

RESTRAINED PIPE LENGTHS

NOTE:
 1. ALL JOINTS, INCLUDING PIPE JOINTS, VALVE JOINTS, AND FITTING JOINTS SHALL BE RESTRAINED WITHIN THE LIMITS OF RESTRAINED LENGTHS LISTED ON THIS TABLE. MECHANICAL RESTRAINTS WILL BE IN ACCORDANCE WITH THE ABOVE TABLE.
 2. THE TABLE SHOWS LENGTHS OF PIPES WHICH MUST BE RESTRAINED ON BOTH SIDES OF THE FITTING.
 3. ALL DEAD END PIPE SHALL BE PROPERLY RESTRAINED PRIOR TO PRESSURE TESTING.
 4. REGISTERED PROFESSIONAL ENGINEER IN THE STATE OF R.I. SHALL VERIFY ALL RESTRAINT CALCULATIONS & LENGTHS DURING DESIGN, MEETING ALL REQUIREMENTS OF THE VEOLIA EXPANSION DEVICE.

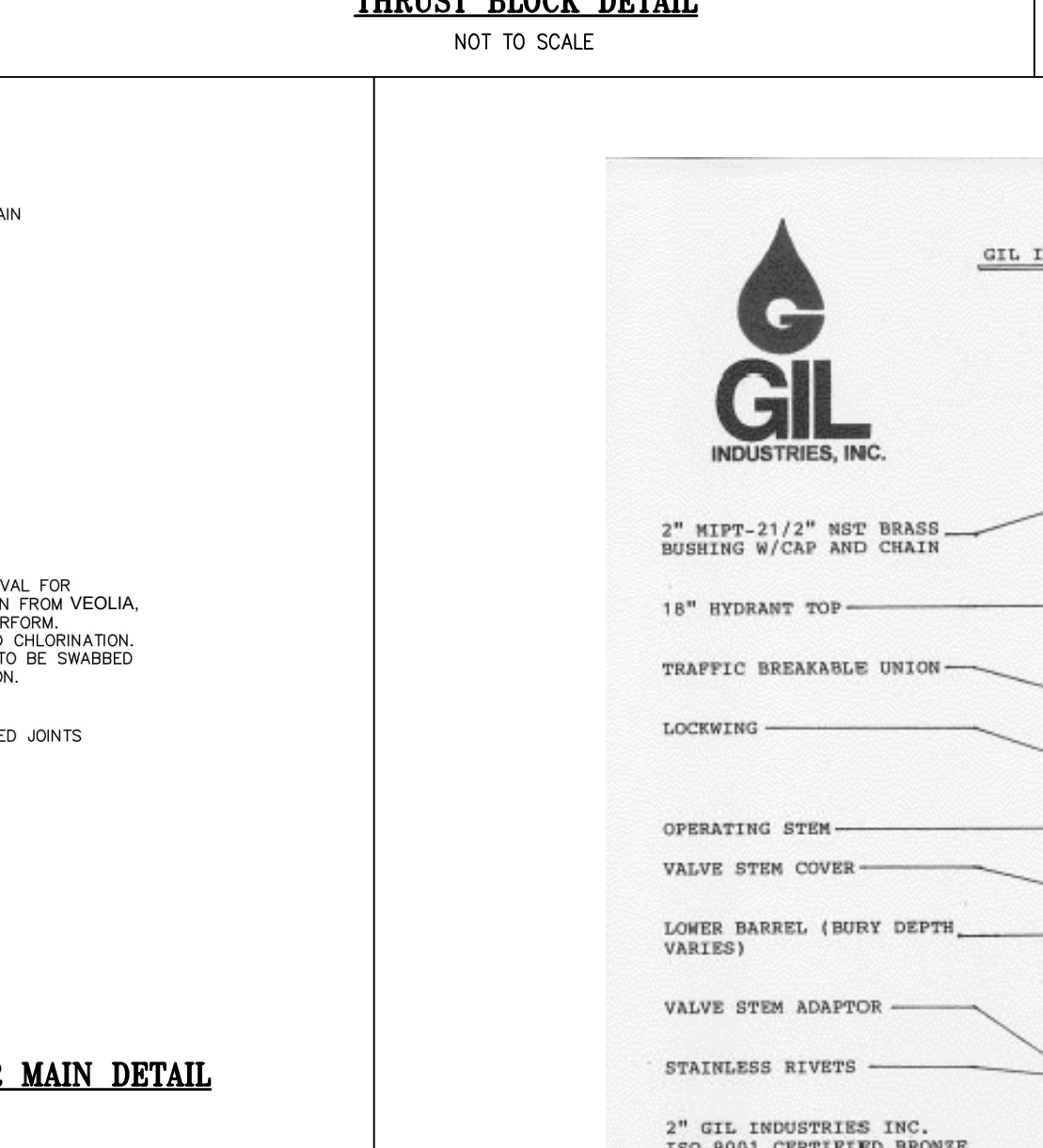
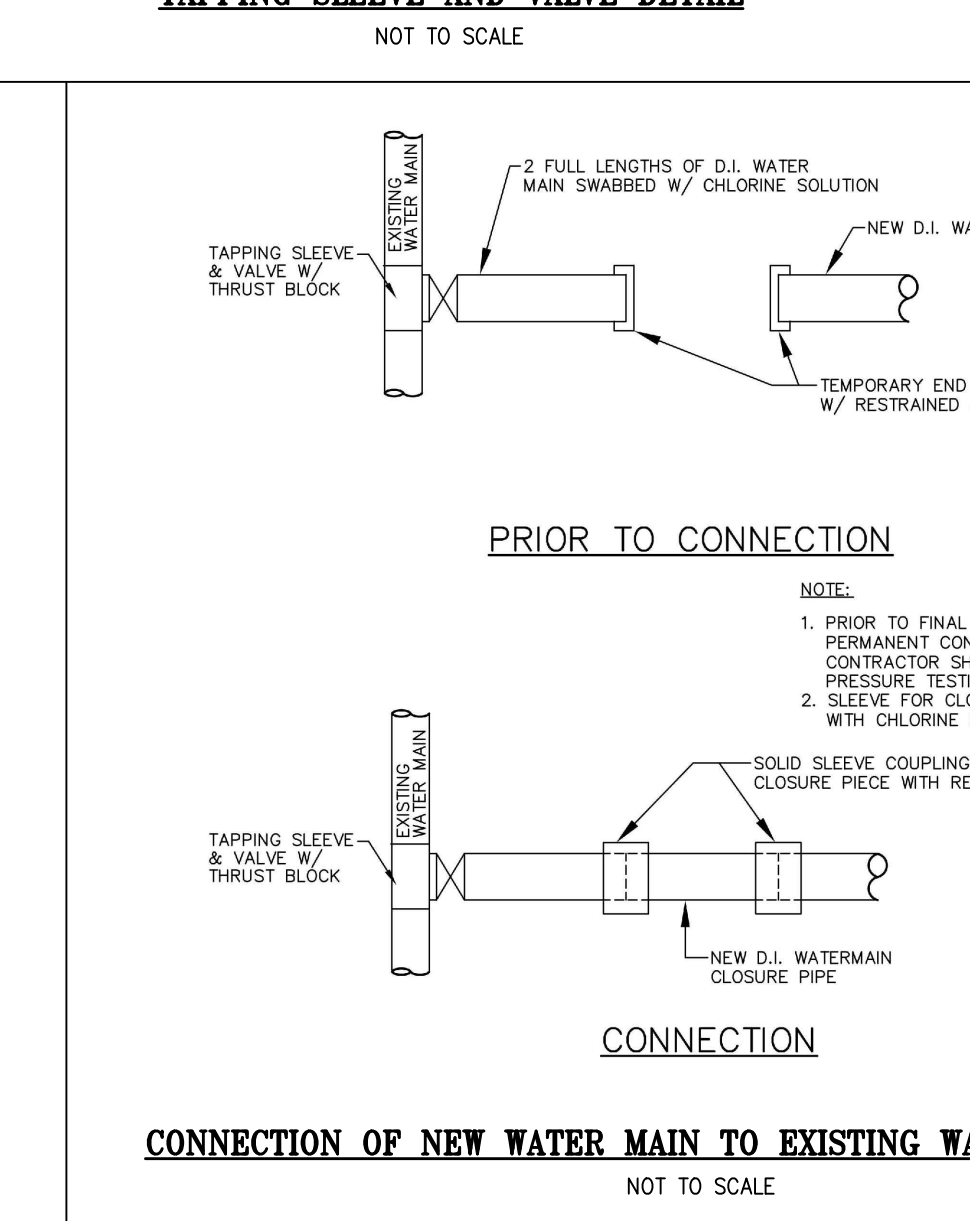

WATER SYSTEM NOTES:

- CONTRACTOR SHALL REVIEW AND COMPLY WITH ALL VEOLIA WATER RHODE ISLAND INC. (VEOLIA) RULES, REGULATIONS, AND INSTALLATION REQUIREMENTS.
- CONTRACTOR TO COORDINATE ANY NECESSARY SHUTDOWN OF EXISTING WATER MAIN WITH VEOLIA PRIOR TO ANY WORK.
- CONSTRUCTION MATERIALS AND METHODS FOR WATER MAINS AND SERVICE CONNECTIONS HAVE BEEN STANDARDIZED BY VEOLIA. THE CONTRACTOR SHALL ONLY USE VEOLIA APPROVED MATERIALS AND METHODS. THE CONTRACTOR SHALL USE VEOLIA MATERIALS AND METHODS WHEN IN CONFLICT WITH DRAWINGS.
- WATER MAIN PIPE, ALL DUCTILE-IRON PIPE AND APPURTENANCES SHALL BE FROM A SINGLE MANUFACTURER SOURCE. FOREIGN PIPE FITTINGS AND GASKETS ARE STRICTLY FORBIDDEN. DUCTILE IRON PIPE SHALL CONFORM TO ANSI/AWWA C153/A21.53, ANSI/AWWA C150/A21.50 CLASS 52 DOUBLE CEMENT MORTAR LINED. GASKETS SHALL CONFORM TO ANSI/AWWA C111/A21.1. ALL PIPES SHALL HAVE A BITUMINOUS OUTSIDE COATING IN ACCORDANCE WITH ANSI/AWWA C153/A21.53 AND ANSI/AWWA C150/A21.53 RESPECTIVELY. ALL PIPES SHALL BE CEMENT-MORTAR LINED AND SEAL COATED IN ACCORDANCE WITH ANSI/AWWA C104/A21.4 EXCEPT THE LINING THICKNESS SHALL BE TWICE THAT SPECIFIED. JOINTS FOR PIPE SHALL BE PUSH-ON (TYTON STYLE ONLY) OR MECHANICAL JOINT CONFORMING TO ANSI/AWWA C111. ALL MECHANICAL JOINT PIPES SHALL BE SUPPLIED WITH ACCESSORIES. RESTRAINED JOINTS SHALL BE SUITABLE FOR 150 PSI WORKING PRESSURE AND FABRICATED OF HEAVY SECTION DUCTILE IRON CASTING. GASKETS SHALL MEET THE MATERIAL REQUIREMENTS OF ANSI/AWWA AND MADE IN THE USA.
 TYPE: DUCTILE IRON MEETING ANSI/AWWA C151/A21.51 ANSI/AWWA C150/A21.50.
 CLASS: SPECIAL THICKNESS CLASS 52.
 LINING: DOUBLE CEMENT MORTAR MEETING ANSI/AWWA C151/A21.5.
 END JOINTS: PUSH ON (TYTON STYLE ONLY) MEETING ANSI/AWWA C111/A21.11.
 MECHANICAL JOINT - MEETING ANSI/AWWA C111/A21.11.
 COATING: EXTERIOR: ANSI/AWWA C104/A21.4.
 INTERIOR: ALL REQUIREMENTS OF EPA FOR POTABLE WATER.
 GASKET: RUBBER MEETING ANSI/AWWA C111/A21.11.
 NITRILE (IN CONTAMINATED SOIL).
- FITTINGS: DUCTILE IRON FITTINGS SHALL CONFORM TO ANSI/AWWA C153/A21.53. FOREIGN FITTINGS, GASKET GLANDS AND ACCESSORIES ARE STRICTLY FORBIDDEN. ALL FITTINGS SHALL HAVE A BITUMINOUS OUTSIDE COATING IN ACCORDANCE WITH ANSI/AWWA C153/A21.53 AND ANSI/AWWA C150/A21.53 RESPECTIVELY. ALL FITTINGS SHALL BE CEMENT-MORTAR LINED AND SEAL COATED IN ACCORDANCE WITH ANSI/AWWA C104/A21.4 EXCEPT THE LINING THICKNESS SHALL BE TWICE THAT SPECIFIED. JOINTS FOR FITTINGS SHALL BE MECHANICAL JOINT CONFORMING TO ANSI/AWWA C111. ALL MECHANICAL JOINT FITTINGS SHALL BE SUPPLIED WITH GLANDS AND ACCESSORIES.
 TYPE: 4 INCH TO 12 INCH DUCTILE IRON COMPACT MEETING ANSI/AWWA C153/A21.53. 16 INCH AND LARGER DUCTILE IRON MEETING ANSI/AWWA C153/A21.53 OR ANSI/AWWA C110/A21.10.
 PRESSURE CLASS: PIPE FITTINGS SHALL HAVE A PRESSURE RATING OF 350 FOR 24-INCH AND SMALLER AND 250 PSI FOR 30-INCH AND LARGER. FITTINGS SHALL AT A MINIMUM HAVE THE SAME PRESSURE RATING AS THE CONNECTING PIPE.
 GASKETS: RUBBER MEETING ANSI/AWWA C111/A21.11. NITRILE (IN CONTAMINATED SOIL).
- VALVES: VALVES SHALL BE CAST IRON OR DUCTILE IRON 250-PSI WORKING PRESSURE. OPERATING STEM SHALL BE PROVIDED WITH A MINIMUM OF TWO (2) O-RING STEM SEALS. BONNET AND GLAND BOLTS/WASHERS SHALL BE STAINLESS STEEL. WEDGES SHALL BE FULLY ENCAPSULATED. THE INTERIOR AND EXTERIOR SURFACES OF ALL CAST IRON OR DUCTILE IRON COMPONENTS SHALL BE FUSION BOND EPOXY COATED. 8 MILS MINIMUM THICKNESS. EPOXY COATING MUST BE UNDAUNTED WITH NO CHIPS OR ABRASIONS. FIELD TOUCH-UP OF INTERIOR COATING IS NOT ALLOWED. FIELD TOUCH-UP OF EXTERIOR SURFACES SHALL BE IN ACCORDANCE WITH MANUFACTURER'S RECOATING SPECIFICATIONS ONLY. CONTRACTORS SHALL USE SPECIAL HANDLING AND INSTALLATION PRECAUTIONS WITH THE USE OF EPOXY COATED VALVES AS NECESSARY TO ENSURE THAT NO COATING SYSTEM DAMAGE OCCURS. AT A MINIMUM FIBER SLINGS OR BELTS SHALL BE USED FOR ALL HANDLING. ALL EPOXY-COATED VALVES SHALL BE PALLETIZED AND PROPERLY SHRINK-WRAPPED UPON DELIVERY TO ASSURE COATING SYSTEM INTEGRITY IS NOT COMPROMISED. ALL EPOXY VALVES FOUND MISHANDLED AT DELIVERY OR DURING INSTALLATION SHALL BE REJECTED AND REMOVED FROM THE JOB SITE. ALL VALVES SHALL BE MANUFACTURED TO MEET OR EXCEED ANSW C509 AND ISO 9000 ALONG WITH THE DESIGN AND OPERATING CHARACTERISTICS OF THE FOLLOWING DEVICES:
 RESILIENT SEAT GATE 4 INCH TO 12 INCH:
 TYPE: BURIED SERVICE NON-RISING STEM.
 ABOVE GRADE SERVICE OR PITS OS & Y WITH HAND WHEEL OR NON-RISING STEM WITH HAND WHEEL.
 WORKING PRESSURE: 250 PSI
 OPENING: LEFT OR RIGHT, DEPENDING ON SYSTEM LOCATION
 STEM: 420 STAINLESS STEEL OR EQUAL WITH MINIMUM 60,000 PSI YIELD STRENGTH
 FASTENERS: STAINLESS STEEL, TYPE 304 FOR ALL OF THE VALVE
 COATINGS: INTERNAL & EXTERIOR TO BE COATED WITH FUSE BONDED HOLIDAY FREE EPOXY COATING MINIMUM 8 MILS NOMINAL THICKNESS MEETING OR EXCEEDING ANSW C550 FULLY RUBBER ENCAPSULATED CAST IRON, DUCTILE IRON OR BRONZE GATE MEETING ANSW C509
 OPERATING NUT: 2 INCH SQUARE OPERATING NUT WITH HEXAGON STAINLESS STEEL BOLT FASTENER
 STEM SEAL: MINIMUM TWO O-RING SEALS
 CONNECTION: MECHANICAL JOINT

TAPPING SLEEVE & VALVE: VALVES SHALL BE FULL BODY AND FULL PORT TAPPING TYPE MEETING THE REQUIREMENTS PARAGRAPH 4.9.1.1 ABOVE. SLEEVES SHALL BE FULL PORT DUCTILE IRON OR GRADE 18-8 TYPE 304 STAINLESS STEEL. DUCTILE IRON SLEEVES SHALL BE OF THE SAME MANUFACTURER AS OF THE VALVE AND BITUMINOUS COATED. ALL SLEEVES SHALL BE MANUFACTURED TO MEET OR EXCEED THE DESIGN AND OPERATING CHARACTERISTICS OF ONE OF THE FOLLOWING DEVICES:
 TYPE: RESILIENT SEAT GATE VALVES DESIGNED SPECIFICALLY FOR TAPPING.
 SEALS: STAINLESS STEEL SLEEVES SHALL USE GRID PATTERN VIRGIN RUBBER ASTM 2000, FULL 360-DEGREE PIPE COVERAGE. DUCTILE IRON SLEEVES SHALL USE MECHANICAL JOINT WITH RUBBER SEALS.
 MAXIMUM WORKING PRESSURE: 4-12 INCH: 250 PSI 16-24 INCH: 200 PSI
 FASTENER: GRADE 18-8 TYPE 304 STAINLESS STEEL.
 COPPER TUBING JOINTS SHALL COMPLY WITH NSF 61 AND CONFORM TO ONE OF THE FOLLOWING TYPES:
 A. BRAZED JOINTS - ALL JOINT SURFACES SHALL BE CLEANED AND APPROVED FLUX SHALL BE APPLIED WHERE REQUIRED. THE JOINT SHALL BE BRAZED WITH A FILL METAL CONFORMING TO AWS A5.8.
 B. FLARED JOINTS - FLARED JOINTS FOR WATER PIPE SHALL BE MADE BY A TOOL DESIGNED FOR THAT OPERATION.
 C. MECHANICAL JOINTS - MECHANICAL JOINTS SHALL BE INSTALLED IN ACCORDANCE WITH THE MANUFACTURER'S INSTRUCTIONS AND BE RATED FOR 200 PSI MINIMUM.
 D. SOLDERED JOINTS - SOLDER JOINTS SHALL BE MADE IN ACCORDANCE WITH THE METHODS OF ASTM B828. ALL CUT TUBE ENDS SHALL BE REAMED TO THE FULL INSIDE DIAMETER OF THE TUBE END. ALL JOINT SURFACES SHALL BE CLEANED. A FLUX CONFORMING TO ASTM B813 SHALL BE APPLIED. THE JOINT SHALL BE SOLDERED WITH A SOLDER CONFORMING TO ASTM B 32. THE JOINING OF WATER SUPPLY PIPING SHALL BE MADE WITH LEAD-FREE SOLDERS AND FLUXES. "LEAD FREE" SHALL MEAN A CHEMICAL COMPOSITION EQUAL TO OR LESS THAN 0.2% LEAD LEVEL.
 PE PIPE AND TUBING JOINTS SHALL COMPLY WITH NSF 61, BE RATED FOR A WORKING PRESSURE OF 200 PSI AND CONFORM TO ONE OF THE FOLLOWING TYPES:
 A. HEAT FUSION JOINTS - JOINT SURFACES SHALL BE CLEAN AND FREE FROM MOISTURE. ALL JOINT SURFACES SHALL BE HEATED TO MELT TEMPERATURE AND JOINED. THE JOINT SHALL BE UNDISTURBED UNTIL COOL. JOINTS SHALL BE MADE IN ACCORDANCE WITH ASTM D2657.
 B. MECHANICAL JOINTS - MECHANICAL JOINTS SHALL BE INSTALLED IN ACCORDANCE WITH THE MANUFACTURER'S INSTRUCTIONS.
 C. GENERAL - PE PIPE SHALL BE CUT SQUARE, WITH A CUTTER DESIGNED FOR PLASTIC PIPE. EXCEPT WHERE JOINED BY HEAT FUSION, PIPE ENDS SHALL BE CHAMFERED TO REMOVE SHARP EDGES. KINKED PIPE SHALL NOT BE INSTALLED. THE MINIMUM PIPE BENDING RADIUS SHALL NOT BE LESS THAN 30 PIPE DIAMETERS, OR THE MINIMUM COIL RADIUS, WHICHEVER IS GREATER. PIPING SHALL NOT BE BENT BEYOND STRAIGHTENING OF THE CURVATURE OF THE COIL. BENDS SHALL NOT BE PERMITTED WITHIN 10 PIPE DIAMETERS OF ANY FITTING OR VALVE. STIFFENER INSERTS SHALL BE INSTALLED WITH COMPRESSION-TYPE COUPLINGS AND FITTINGS SHALL NOT EXTEND BEYOND THE CLAMP OR NUT OF THE COUPLING OR FITTING.
 CORPORATION STOPS SHALL BE BALL TYPE WITH EITHER STAINLESS STEEL, SYNTHETIC COATED BRASS BALL OR NICKEL COATED BRASS BALL DESIGNED FOR POTABLE WATER SERVICE UP TO 300 PSI. BODY SHALL BE HEAVY CAST LEAD FREE "ENVIROBRASS" UNS ALLOY NUMBER C8920 ASTM B584-98 AND/OR ANSW C880/ASTM B-62 MEETING OR EXCEEDING THE LEAD LEACHING PERFORMANCE SPECIFICATIONS OF ANSI/NSF 61 STANDARD. ALL CORPORATION STOPS SHALL MEET OR EXCEED DESIGN STANDARDS OF ANWA C800 ALONG WITH THE FOLLOWING:
 A. TYPE: FORD OR EQUAL
 B. OPEN = OPEN LEFT
 C. END CONNECTIONS = COMPRESSION WITH NON-CORROSIVE GRIP RING MEETING ASTM B-159-BUNA N RUBBER AND CONDUCTIVITY RING. THREADED END SHALL BE ANWA CC TAPER THREAD FOR DIRECT TAP.
 CURB STOPS SHALL BE BALL TYPE WITH EITHER STAINLESS STEEL, SYNTHETIC COATED BRASS BALL OR NICKEL COATED BRASS BALL DESIGNED FOR POTABLE WATER SERVICE UP TO 300 PSI. BODY SHALL BE HEAVY CAST LEAD FREE "ENVIROBRASS" UNS ALLOY NUMBER C8920 ASTM B584-98 AND/OR ANWA C880/ASTM B-62 MEETING OR EXCEEDING THE LEAD LEACHING PERFORMANCE SPECIFICATIONS OF ANSI/NSF 61 STANDARD. ALL CURB STOPS SHALL MEET OR EXCEED DESIGN STANDARDS OF ANWA C800 ALONG WITH THE FOLLOWING:
 A. TYPE: FORD OR EQUAL
 B. OPEN = OPEN LEFT
 C. END CONNECTIONS = COMPRESSION WITH NON-CORROSIVE GRIP RING MEETING ASTM B-159-BUNA N RUBBER AND CONDUCTIVITY RING. DRAIN = NONE
 SADDLE FOR SERVICE CONNECTION TO DUCTILE IRON MAIN, IF USED, SHALL BE DUCTILE IRON OR TYPE 304 STAINLESS STEEL WITH STAINLESS STEEL BOLTS, WASHERS, NUTS AND BANDS. DUCTILE IRON COMPONENTS SHALL BE COATED WITH FUSION BONDED EPOXY MINIMUM 8 MILS THICKNESS MEETING OR EXCEEDING ANWA C550 OR NYLON COATED.
 A. TYPE = FORD OR EQUAL (SADDLE ON 8" DUCTILE IRON MAIN)
 B. BODY = DUCTILE IRON OR GRADE 18-8 TYPE 304 STAINLESS STEEL
 C. BAND = GRADE 18-8 TYPE 304 STAINLESS STEEL DOUBLE BAND.
 D. FASTENERS = 304 STAINLESS STEEL STUD, NUT & WASHERS.
 E. GASKET = VIRGIN RUBBER ASTM 2000.
 F. OUTLET = THREADED OUTLET TAPPED TO ANWA C800 FOR THE APPROPRIATE SERVICE SIZE.
 DUCTILE IRON COUPLINGS, STRAIGHT AND TRANSITION COUPLINGS SHALL BE DUCTILE IRON MANUFACTURED TO MEET ANWA C 218 AND FITTED WITH STAINLESS STEEL BOLTS, WASHERS AND NUTS. DUCTILE IRON COMPONENTS SHALL BE COATED WITH FUSION BONDED EPOXY MINIMUM 8 MILS THICKNESS MEETING OR EXCEEDING ANWA C550. COUPLINGS SHALL BE MANUFACTURED TO MEET OR EXCEED THE DESIGN AND OPERATING CHARACTERISTICS OF THE FOLLOWING:
 TYPE: FORD OR EQUAL
 BODY: DUCTILE IRON
 COATING: DUCTILE IRON COMPONENTS SHALL BE EPOXY COATED ANWA C 500.
 FASTENERS: 304 STAINLESS STEEL STUD, NUT & WASHERS.
 GASKET: RUBBER ASTM 2000.

11. ALL METERS SHALL BE COMPATIBLE WITH THE SYSTEM UTILIZED BY THE VEOLIA. THE NEPTUNE E-CODER R-900. ALL METERS SHALL READ IN CUBIC FEET AND BE CAPABLE OF BEING READ BY THE RADIO FREQUENCY SYSTEM USED BY VEOLIA. REGISTER SHALL CONTAIN A 9-DIGIT LOCAL REGISTRATION AND 4-8 DIGITS CAN BE COMMUNICATED FOR BILLING PURPOSES.

12. SERVICE BOXES (LOCATED OFF ROADWAYS) SHALL BE MANUFACTURED IN NORTH AMERICA. THEY SHALL BE HEAVY PATTERN CAST IRON, BUFFALO STYLE, SELF ADJUSTABLE TYPE WITH HEAVY CAST IRON COVER AND BRASS BOLT FASTENER TYPE LOCK. THE WORD "WATER" SHALL BE CAST UPON THE COVER IN HEAVY PATTERN RAISED LETTERS. COVERS SHALL BE DROP IN TYPE WITHOUT FINIS SOLID RING. BOXES SHALL HAVE A BITUMINOUS INTERNAL AND EXTERNAL COATING IN ACCORDANCE WITH ANSI/AWWA C151/A21.51 AND ANSI/AWWA C153/A21.53 RESPECTIVELY. BOXES SHALL HAVE BARRELS OF NOT LESS THAN 2-1/2" IN DIAMETER. THE UPPER PORTION OF EACH BOX SHALL HAVE A BOTTOM FLANGE OF SUFFICIENT BEARING AREA TO PREVENT SETTLING. THE BASE OF THE LOWER SECTION SHALL BE A REINFORCED ARCH CONFIGURATION AND SIZED TO ENCLOSE THE CURB STOP. BOX SECTIONS SHALL BE OF SUFFICIENT LENGTH TO PROVIDE COMPLETE COVERAGE FOR THE DEPTH OF BURY.

13. VALVE ROAD BOXES ALL VALVES LOCATED IN ROADWAYS (EXCEPT SWING-CHECK) SHALL BE EQUIPPED WITH A CAST IRON "BUFFALO" TYPE, ADJUSTABLE (SLIDING) VALVE ROAD BOX. THE UPPER PORTION SHALL BE 28 INCH LONG AND THE BOTTOM SECTION 48 INCH (MIN). COVERS SHALL BE 3-1/4" IN DIAMETER SOLID RING SEAT WITH THE WORD "WATER" (IN CAPS) CAST UPON IT. THE UPPER PORTION OF THE BOX SHALL BE MANUFACTURED WITH A HEAVY FLANGE HAVING SUFFICIENT BEARING AREA TO PREVENT SETTLEMENT. THE LOWER SECTION SHALL BE CONFIGURED TO ENCLOSE THE VALVE STUFFING BOX WITH AN INSIDE DIAMETER OF AT LEAST 4-1/4 INCH. THE INSTALLED BOX SHALL BE CAPABLE OF VERTICAL ADJUSTMENT OF A MINIMUM OF 6 INCH WHILE MAINTAINING AN OVERLAP OF A LEAST 4 INCH BETWEEN SECTIONS.

14. ALL HOSE BIBS PROVIDED FOR THE HOUSES SHALL BE OF THE DESIGN, WHICH INCORPORATES A BUILT-IN TAMPER PROOF VACUUM BREAKER FEATURE AS MANUFACTURED BY THE BOSE BIB MAKER. ALL HOSE BIB FIXTURES SHALL BE AMERICAN MADE. THIS REQUIREMENT IS APPLICABLE TO ALL INTERIOR AND EXTERIOR HOSE BIB APPLICATIONS. EXISTING FIXTURES SHALL BE RETROFITTED WITH NON-REMOVABLE HOSE BIB VACUUM BREAKER ASSEMBLIES SPECIFICALLY DESIGNED TO ADAPT TO THE EXISTING HOSE BIB CONFIGURATION.

15. THE PROPERTY OWNER SHALL BE RESPONSIBLE TO INSTALL AN APPROPRIATE THERMAL EXPANSION DEVICE IN THE FACILITY TO COMPLY WITH CROSS CONNECTION REQUIREMENTS OF THE RHODE ISLAND PLUMBING CODE.

16. MINIMUM COVER OVER WATER PIPE IS 5 FEET.

17. PROVIDE WARNING TAPE OVER SERVICE AS SHOWN IN TRENCH DETAIL.

18. THE WATER MAIN AND SERVICES SHALL BE FILLED, FLUSHED, HYDROSTATICALLY PRESSURE TESTED TO 150 PSI AND CHLORINATED WITH VEOLIA'S REGULATIONS, ANWA C651, RHODE ISLAND DEPARTMENT OF HEALTH, AND "ANWA MANUAL OF WATER SUPPLY PRACTICE MSS - PE PIPE DESIGN AND INSTALLATION". REFER TO SECTION 3.23 "DISINFECTION/CHLORINATION" OF THE VEOLIA RULES AND REGULATIONS AND VEOLIA'S CUSTOMER WATER SERVICE DISINFECTION POLICY. NOTE: MAXIMUM VELOCITY WHEN FILLING THE PE PIPE WITH WATER SHALL BE 1 FT/SEC (1 GAL/MIN FOR 1" CTS PIPE).

19. A MINIMUM OF TEN-FOOT HORIZONTAL SEPARATION SHALL BE MAINTAINED IN THE PLACEMENT OF WATER MAINS, SERVICES OR APPURTENANCES WITHIN THE VICINITY OF SEWER FACILITIES OR VICE VERSA. WHERE WATER MAINS CROSS SEWER MAINS, THE CROWN OF THE SEWER MAIN SHALL BE AT LEAST 18-INCHES BELOW THE BOTTOM OF THE WATER MAIN. IN CASES WHERE IT IS NOT POSSIBLE TO MAINTAIN A 10-FOOT, HORIZONTAL SEPARATION OR IN THE CASE OF CROSSING THE EIGHTEEN-INCH VERTICAL SEPARATION, A DEVIATION FROM THIS RESTRICTION MAY BE ALLOWED ON A CASE BY CASE BASIS WITH PRIOR APPROVAL FROM THE GENERAL MANAGER/CHIEF ENGINEER AS TO THE PROPOSED MATERIALS AND INTERVENTIONS TO BE TAKEN TO PROTECT THE WATER SYSTEM FROM THE POSSIBILITY OF CONTAMINATION. IN ALL CASES, FORCE MAIN SEWER INFRASTRUCTURE MUST BE LOCATED BELOW WATER MAINS.

20. METALIZED IDENTIFICATION TAPE 2" IN WIDTH OR GREATER, BLUE IN COLOR AND PRINTED WITH "CAUTION WATER LINE BURIED BELOW" SHALL BE UTILIZED OVER ALL WATER LINES AND SERVICES. SET TO A DEPTH FROM FINISHED GRADE OF NO MORE THAN 1'-0".

21. A TEMPORARY PATCH SHALL BE INSTALLED OVER THE FRESHLY BACKFILLED TRENCH IN AN EXISTING STREET OR SIDEWALK USING HOT BITUMINOUS CONCRETE. IT SHALL BE AT LEAST 3" THICK CONSISTING OF EQUAL THICKNESS LAYERS OF MODIFIED BINDER AND TYPE 1-1 WEARING COURSE. AFTER 60 DAYS, THE TEMPORARY PATCH SHALL BE REMOVED AND REPLACED WITH A PERMANENT PATCH. ALL PAVEMENT DEEPS SHALL BE SAW CUT.

22. AN AS-BUILT PLAN IS REQUIRED. CONTRACTOR SHALL RETAIN THE SERVICES OF A RHODE ISLAND PROFESSIONAL LAND SURVEYOR TO INSPECT THE SERVICE AND PREPARE THE AS-BUILT PLAN IN ACCORDANCE WITH THE VEOLIA RULES AND REGULATIONS.

OWNER:
 SHELEEN CLARKE
 96 DUCK COVE ROAD
 NORTH KINGSTOWN, RI 02852

APPLICANT:
 NEW ENGLAND PROPERTIES, LLC
 257 WICKFORD CT.
 NORTH KINGSTOWN, RI 02852

TIMOTHY J. BEHAN
 No. 6278
 REGISTERED PROFESSIONAL ENGINEER
 11/24/2024

REVISIONS

No.	DATE	DRWN	CHKD
1	4/2/24	TB	TB
2	4/18/24	TB	TB
3	9/6/24	SMA	TB
4	9/30/24	SMA	TB
5	10/21/24	SMA	TB
6	11/24/24	SMA	TB

COMMONWEALTH ENGINEERS & CONSULTANTS, INC.
 400 SMITH STREET
 PROVIDENCE, RHODE ISLAND 02908
 (401) 273-6600

PERMIT AGENCY REVIEW PLAN
 FOR
 VILLAGE AT BROAD ROCK
 PLAT 33, LOT 24
 ON
 BROAD ROCK ROAD
 SOUTH KINGSTOWN, RHODE ISLAND
 CONSTRUCTION DETAILS PLAN-4

SCALE: AS SHOWN SHEET NO: 15 OF 17
 DRAWN BY: SMA DESIGN BY: SMA CHECKED BY: TJB
 DATE: FEBRUARY 2024 PROJECT NO: 23011.00

RHODE ISLAND DEPARTMENT OF TRANSPORTATION
BALED STRAW DITCH AND SWALE EROSION CHECK
 R.I. STANDARD 9.4.0
 DATE: JUNE 15, 1998

RHODE ISLAND DEPARTMENT OF TRANSPORTATION
PRECAST CONCRETE FLARED END SECTION
 R.I. STANDARD 2.3.0
 DATE: JUNE 15, 1998

RHODE ISLAND DEPARTMENT OF TRANSPORTATION
PRECAST 4'-0" ROUND MANHOLE
 R.I. STANDARD 4.2.0
 DATE: JUNE 15, 1998

RHODE ISLAND DEPARTMENT OF TRANSPORTATION
CATCH BASIN AND MANHOLE
 R.I. STANDARD 5.3.0
 DATE: JUNE 15, 1998

RHODE ISLAND DEPARTMENT OF TRANSPORTATION
CONCRETE COLLARS
 R.I. STANDARD 5.4.0
 DATE: JUNE 15, 1998

RHODE ISLAND DEPARTMENT OF TRANSPORTATION
STONEWALL CONSTRUCTION DETAIL
 NOT TO SCALE

RHODE ISLAND DEPARTMENT OF TRANSPORTATION
SIGN POST SELECTION AND INSTALLATION DETAILS
U-CHANNEL POST (SIGNS UP TO 8'-0" W x 4'-0" H)
 R.I. STANDARD 24.2.0
 DATE: JUNE 15, 1998

RHODE ISLAND DEPARTMENT OF TRANSPORTATION
HEAVY-DUTY ROUND FRAME AND COVER
 R.I. STANDARD 6.2.1
 DATE: JUNE 15, 1998

RHODE ISLAND DEPARTMENT OF TRANSPORTATION
ABOVE-GROUND WATER METER & BACKFLOW PREVENTION ENCLOSURE
 NOT TO SCALE

RHODE ISLAND DEPARTMENT OF TRANSPORTATION
OPEN SPACE MARKER DETAIL
 NOT TO SCALE

SIGN NUMBER		*R1-1			
LEGEND		STOP			
		BACKGROUND	RED		
COLOR	COPY	WHITE			
	WIDTH	24"	30"	36"	48"
SIGN DIMENSION	HEIGHT	24"	30"	36"	48"

OWNER:
 SHELEEN CLARKE
 96 DUCK COVE ROAD
 NORTH KINGSTOWN, RI 02852

APPLICANT:
 NEW ENGLAND PROPERTIES, LLC
 257 WICKFORD CT.
 NORTH KINGSTOWN, RI 02852

TIMOTHY J. BEHAN
 No. 6278
 REGISTERED PROFESSIONAL ENGINEER
 11/24/2024

COMMONWEALTH ENGINEERS & CONSULTANTS, INC.
 400 SMITH STREET
 PROVIDENCE, RHODE ISLAND 02908
 (401) 273-6600

PERMIT AGENCY REVIEW PLAN
 FOR
 VILLAGE AT BROAD ROCK
 PLAT 33, LOT 24
 ON
 BROAD ROCK ROAD
 SOUTH KINGSTOWN, RHODE ISLAND
CONSTRUCTION DETAILS PLAN-5

SCALE: AS SHOWN	SHEET NO: 16 OF 17	
DRAWN BY: SMA	DESIGN BY: SMA	CHECKED BY: TJB
DATE: FEBRUARY 2024	PROJECT NO: 23011.00	

REVISIONS

No.	DATE	DRWN	CHKD
1	4/2/24	TB	TB
2	4/18/24	TB	TB
3	9/6/24	SMA	TB
4	9/30/24	SMA	TB
5	10/21/24	SMA	TB
6	11/24/24	SMA	TB

MONUMENTS NOTES:

- MONUMENTS (CONCRETE BOUNDARY MARKERS) SHALL BE OF THE TYPE FURNISHED BY THE TOWN, PAID FOR BY THE DEVELOPER AND PLACED BY A REGISTERED LAND SURVEYOR ON THE STREET LINE AT THE BEGINNING AND END OF ALL HORIZONTAL CURVES ON BOTH SIDES OF EACH SUBDIVISION (PUBLIC) STREET AND SHALL NOT BE MORE THAN FIVE HUNDRED FEET APART.
- MONUMENTS SHALL BE SET FOUR INCHES ABOVE FINISHED GRADE OF THE CENTER OF THE STREET

NOTES:

- EXISTING PARCEL, (A.P. 33 LOT 24) CONSIST OF 16.50±ACRES THAT ARE ZONED R-40.
- WETLAND FLAGS DELINEATED BY AVIZINIS ENVIRONMENTAL SERVICES, INC. 2022.
- OFF SITE BUILDING LOCATIONS ARE APPROXIMATE AND HAVE BEEN TAKEN FROM AERIAL PHOTOGRAPHY.
- ELEVATIONS BASED ON NAVD88 VERTICAL DATUM.
- A SMALL PORTION OF SUBJECT SITE IS SITUATED IN FEMA 100-YR FLOOD ZONE 'A' AS DEPICTED ON MAP 44009C0201, EFFECTIVE 4/3/2020. THE REMAINING PORTION OF THE SITE IS SITUATED IN ZONE 'X' WHICH IS AREA OF MINIMAL FLOOD HAZARD.
- THERE IS NO EXISTING AGRICULTURAL USE ON THE SITE.
- THE ENTIRE AND SURROUNDING PROPERTIES CONTAIN PRIME AGRICULTURAL SOILS AND FARMLAND SOILS OF IMPORTANCE, PROPERTY.
- THERE ARE NO EXISTING STREETS, DRIVEWAYS, FARM ROADS, WOODS ROADS AND/OR TRAILS THAT HAVE BEEN IN PUBLIC USE.
- THERE ARE NO HISTORIC CEMETERIES LOCATED ON OR ADJACENT TO THE SITE.
- THE SITE IS LOCATED WITHIN A NATURAL HERITAGE AREA AS DEFINED BY RIDEM.
- THE SITE IS NOT LOCATED WITHIN A DRINKING WATER RESERVOIR, GROUNDWATER RECHARGE AREA OR SOLE SOURCE ACQUIFER AS DEFINED BY RIDEM.
- THE SITE IS NOT LOCATED IN A CRMC SAMP AREA, A TOWN OF SOUTH KINGSTOWN GROUNDWATER PROTECTION OVERLAY DISTRICT OR AN OWTS CRITICAL RESOURCE AREA.
- THE SITE AND ANY EXISTING BUILDINGS ON THE SITE ARE NOT LISTED ON THE NATIONAL REGISTER OF HISTORIC PLACES.
- THE SAUGATUCKET RIVER HAS A TMDL FOR FECAL COLIFORM.

PROPOSED SUBDIVISION LOT SUMMARY		
LOT	AREA (SQ. FT.)	AREA (ACRES)
1	10,713	0.25
2	10,347	0.24
3	12,376	0.28
4	11,086	0.25
5	10,583	0.24
6	10,859	0.25
7	10,484	0.24
8	11,174	0.26
9	16,014	0.37
10	18,851	0.43
11	10,158	0.23
12	14,139	0.32
13	12,679	0.29
14	10,082	0.23
15	12,784	0.29
16	12,026	0.28
17	10,306	0.24
18	10,848	0.25
19	11,430	0.26
TOTAL LOTS	226,939	5.21
DRIVEWAY /UTILITY EASEMENT	53,689	1.23
LAND UNSUITABLE	70,567	1.62
STORMWATER POND	33,424	0.77
OPEN SPACE	334,230	7.65
TOTAL AREA	718,849	16.50

DRIVEWAY AND UTILITY EASEMENT CURVE TABLE					
Curve #	Length	Radius	Delta	Chord Direction	Chord Length
C17	23.83	15.00	91.01	S52° 12' 12" W	21.40
C18	23.30	15.00	88.99	S37° 47' 48" E	21.02
C19	29.63	220.00	7.72	N86° 08' 55" W	29.61
C20	24.24	180.00	7.72	S86° 08' 55" E	24.22
C21	65.86	180.00	20.96	N79° 31' 28" W	65.50
C22	80.50	220.00	20.96	S79° 31' 28" E	80.05
C23	116.51	220.00	30.34	N84° 12' 48" W	115.15
C24	95.32	180.00	30.34	S84° 12' 48" E	94.21
C25	185.62	80.00	132.94	N34° 28' 50" W	146.70
C26	277.83	120.00	132.65	S34° 20' 12" E	219.80
C27	105.80	80.00	75.77	N69° 52' 34" E	98.26
C28	158.70	120.00	75.77	S69° 52' 34" W	147.38
C29	15.03	15.00	57.42	S43° 31' 38" E	14.41
C30	15.03	15.00	57.42	S79° 03' 06" W	14.41
C31	257.30	50.00	294.84	N17° 45' 44" E	53.85

DRIVEWAY AND UTILITY EASEMENT LINE TABLE		
Line #	Length	Direction
L15	70.01	N6° 41' 49.99" E
L16	16.04	N82° 17' 25.42" W
L17	17.28	S82° 17' 25.42" E
L18	77.10	N89° 59' 34.86" E
L19	77.10	S89° 59' 34.86" W
L20	71.18	N69° 02' 31.46" W
L21	71.18	S69° 02' 31.46" E
L22	226.00	S80° 36' 54.91" W
L23	225.51	N80° 36' 54.91" E
L24	119.77	N31° 59' 23.81" E
L25	119.77	S31° 59' 23.81" W
L26	41.22	N72° 14' 16.26" W
L27	41.22	S72° 14' 16.26" E

SURVEY CERTIFICATION:
 THIS SURVEY HAS BEEN CONDUCTED AND THE PLAN HAS BEEN PREPARED PURSUANT TO SECTION 9 OF THE RULES AND REGULATIONS ADOPTED BY THE RHODE ISLAND STATE BOARD OF REGISTRATION FOR PROFESSIONAL LAND SURVEYORS ON MARCH 16, 2020 AS FOLLOWS:
 LIMITED CONTENT BOUNDARY SURVEY: CLASS I
 THE PURPOSE FOR THE CONDUCT OF THE SURVEY AND FOR THE PREPARATION OF THE PLAN IS TO ESTABLISH AND SET BOUNDARY LINES.

Curt A. Nunes
 REGISTERED LAND SURVEYOR
 DATE: 12/04/2024

COMMONWEALTH LAND SURVEYORS, INC.
 4 PATRIOT STREET
 ATTLEBORO, MASSACHUSETTS 02703
 (508) 455-2634
 C.O.A. # LS-A395

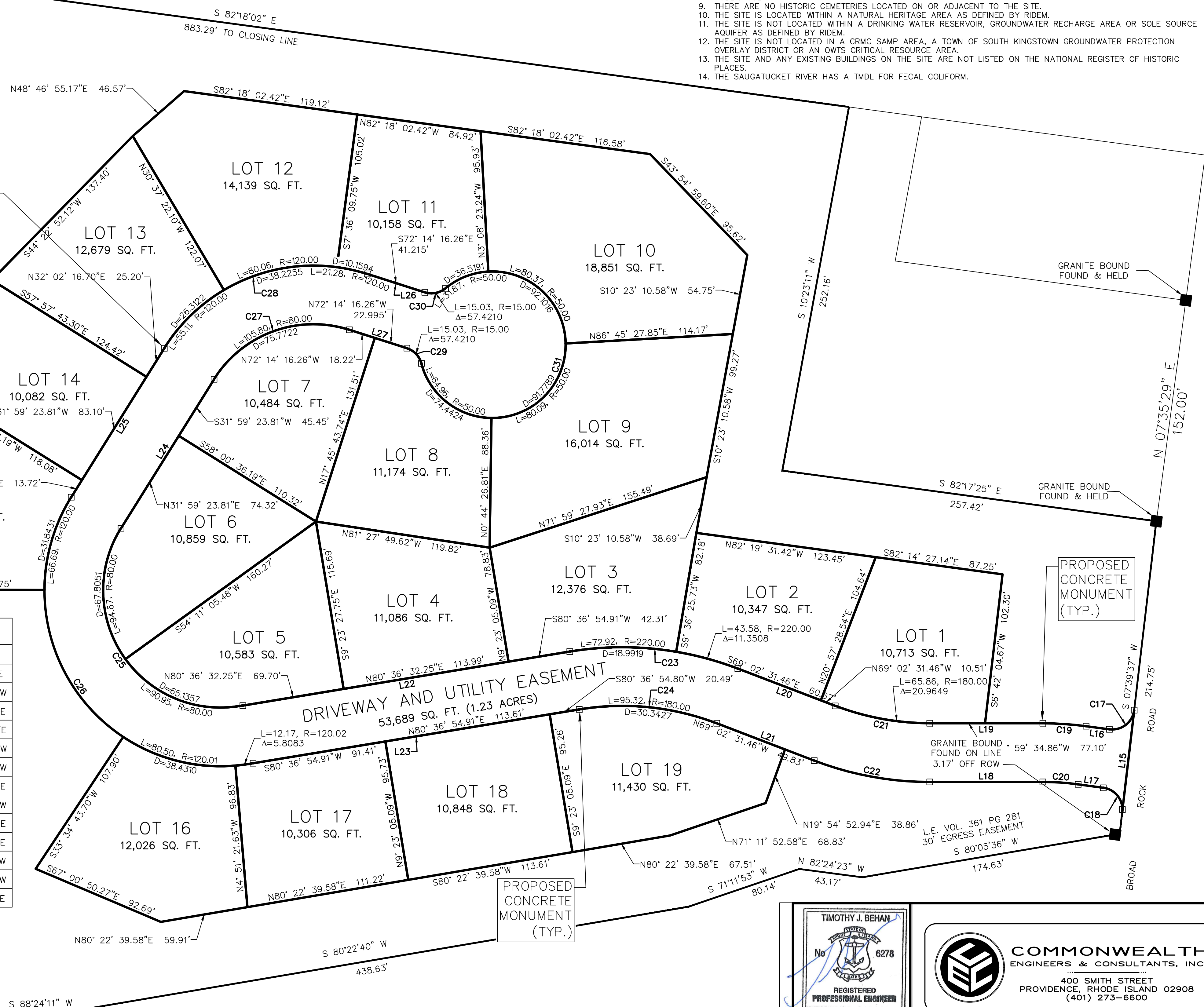

S 81°32'34" W
 460.30' TO CLOSING LINE

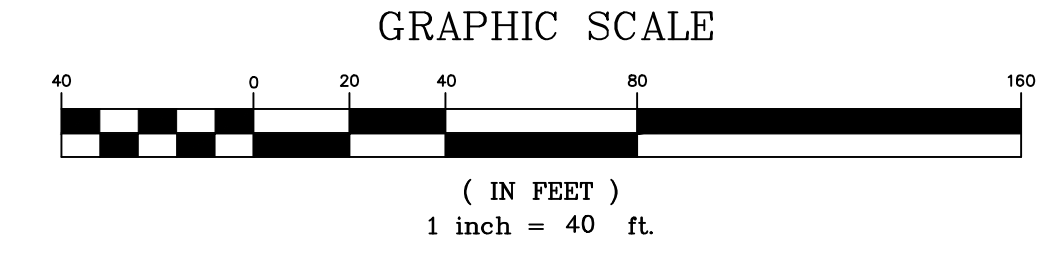

PROPOSED RECORD PLAN

SCALE: 1" = 40'

TIMOTHY J. BEHAN
 No. 6278
 REGISTERED PROFESSIONAL ENGINEER
 11/24/2024

COMMONWEALTH ENGINEERS & CONSULTANTS, INC.
 400 SMITH STREET
 PROVIDENCE, RHODE ISLAND 02908
 (401) 273-6600

REVISIONS				
No.	DATE	DRWN	CHKD	
1	4/2/24	TB	TB	
2	4/18/24	TB	TB	
3	9/6/24	SMA	TB	
4	9/30/24	SMA	TB	
5	10/21/24	SMA	TB	
6	11/24/24	SMA	TB	

PERMIT AGENCY REVIEW PLAN
 FOR
VILLAGE AT BROAD ROCK
PLAT 33, LOT 24
 ON
BROAD ROCK ROAD
SOUTH KINGSTOWN, RHODE ISLAND
PROPOSED RECORD PLAN

SCALE: AS SHOWN SHEET NO: 17 OF 17
 DRAWN BY: SMA DESIGN BY: SMA CHECKED BY: TJB
 DATE: FEBRUARY 2024 PROJECT NO 23011.00

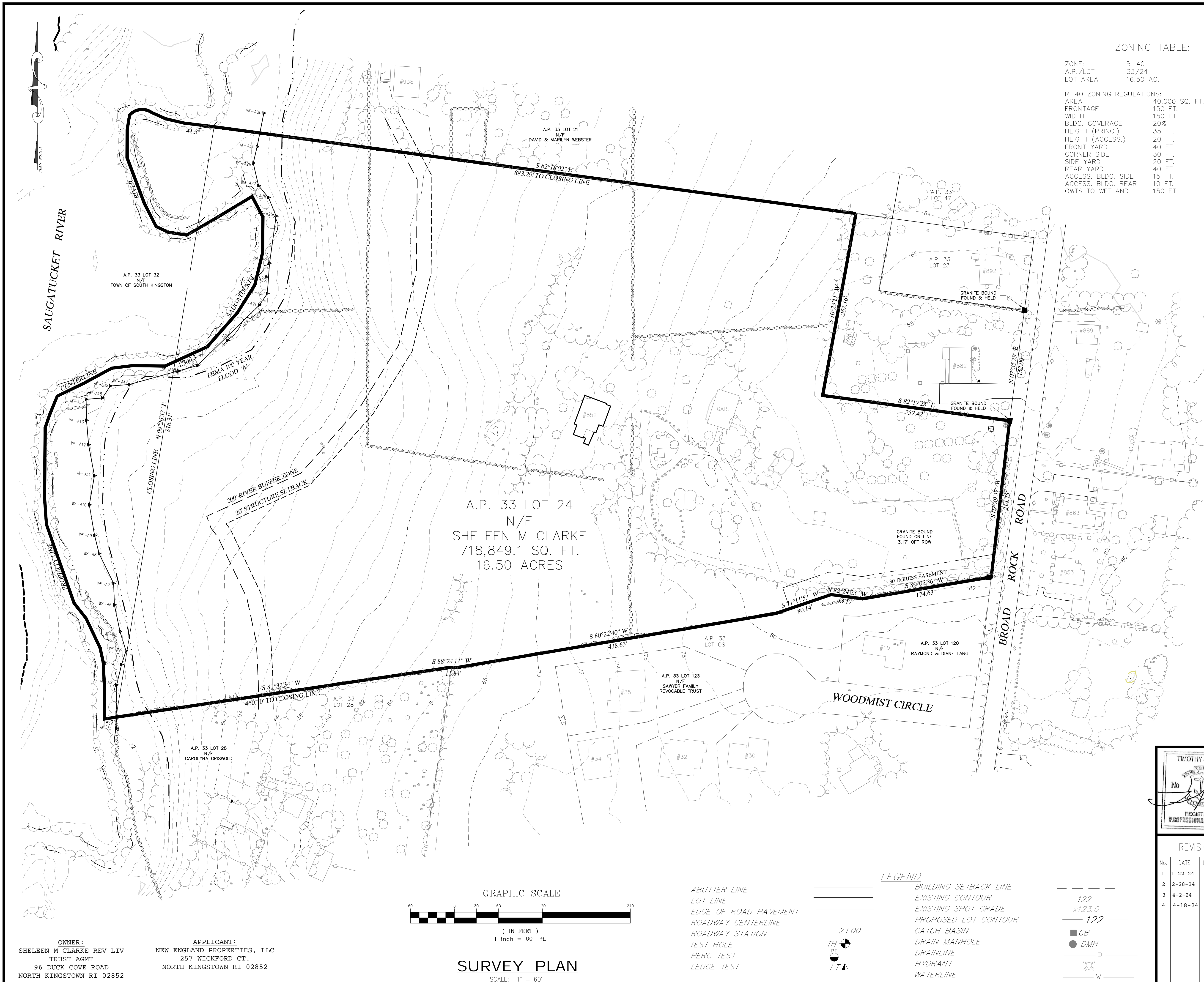

ZONING TABLE:

ZONE:	R-40
A.P./LOT	33/24
LOT AREA	16.50 AC.

R-40 ZONING REGULATIONS:

AREA	40,000 SQ. FT.
FRONTAGE	150 FT.
WIDTH	150 FT.
BLDG. COVERAGE	20%
HEIGHT (PRINC.)	35 FT.
HEIGHT (ACCESS.)	20 FT.
FRONT YARD	40 FT.
CORNER SIDE	30 FT.
SIDE YARD	20 FT.
REAR YARD	40 FT.
ACCESS. BLDG. SIDE	15 FT.
ACCESS. BLDG. REAR	10 FT.
OWTS TO WETLAND	150 FT.

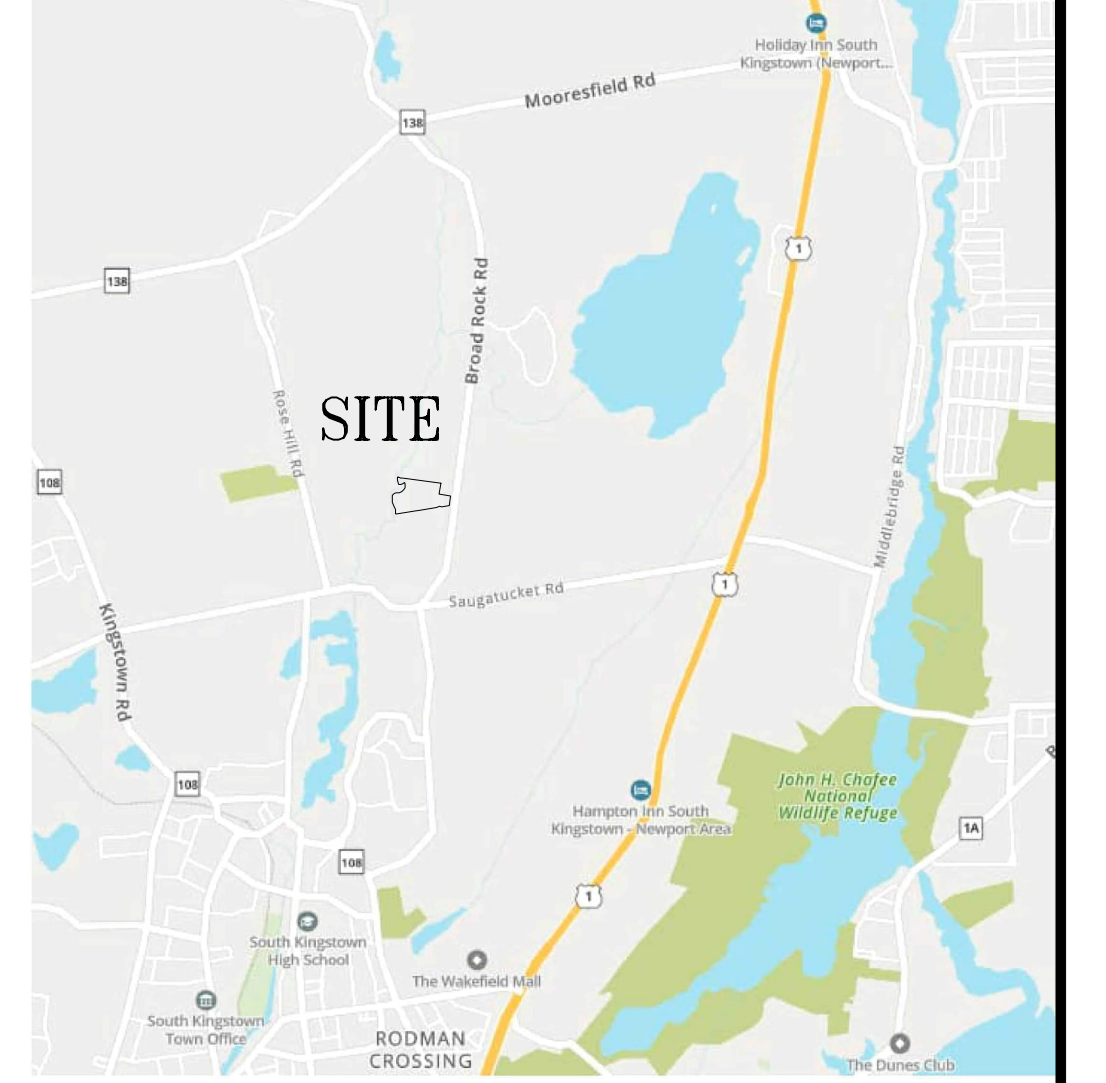

- NOTES:**
1. WETLAND FLAGS DELINEATED BY AVIZINIS ENVIRONMENTAL SERVICES, INC. 2022.
 2. OFF SITE BUILDING LOCATIONS ARE APPROXIMATE AND HAVE BEEN TAKEN FROM AERIAL PHOTOGRAPHY.
 3. ELEVATIONS BASED ON NAVD88 VERTICAL DATUM.
 4. A SMALL PORTION OF SUBJECT SITE IS SITUATED IN FEMA 100-YR FLOOD ZONE 'A' AS DEPICTED ON MAP 44009C0201J, EFFECTIVE 4/3/2020. THE REMAINING PORTION OF THE SITE IS SITUATED IN ZONE 'X' WHICH IS AREA OF MINIMAL FLOOD HAZARD.

LAND UNSUITABLE FOR DEVELOPMENT:

WETLANDS	1.17 AC.
COASTAL WETLANDS	0.00 AC.
HIGH FLOOD DANGER ZONE	0.45 AC.
EASEMENTS (ABOVE GRND. UTILITY)	0.00 AC.

SURVEY CERTIFICATION:

THIS SURVEY HAS BEEN CONDUCTED AND THE PLAN HAS BEEN PREPARED PURSUANT TO SECTION 9 OF THE RULES AND REGULATIONS ADOPTED BY THE RHODE ISLAND STATE BOARD OF REGISTRATION FOR PROFESSIONAL LAND SURVEYORS ON MARCH 16, 2020 AS FOLLOWS:

LIMITED CONTENT BOUNDARY SURVEY: CLASS I
DATA ACCUMULATION SURVEY: CLASS III

THE PURPOSE FOR THE CONDUCT OF THE SURVEY AND FOR THE PREPARATION OF THE PLAN IS TO ESTABLISH AND SET BOUNDARY LINES WITH TOPOGRAPHIC INFORMATION FOR FUTURE DEVELOPMENT.

Curt A. Nunes
02/16/2023
REGISTERED LAND SURVEYOR DATE

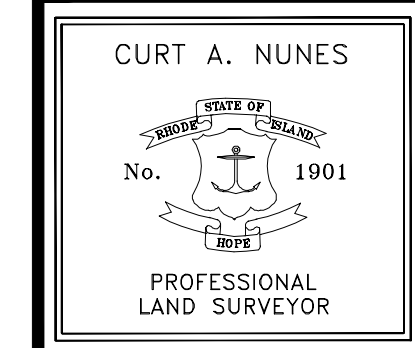

COMMONWEALTH
LAND SURVEYORS, INC.
4 PATRIOT STREET
ATTLEBORO, MASSACHUSETTS 02703
(508) 455-2634
C.O.A. # LS-A395

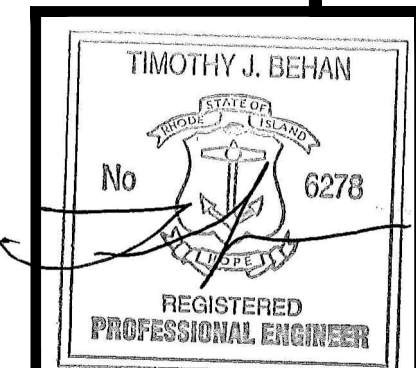

COMMONWEALTH
ENGINEERS & CONSULTANTS, INC.
400 SMITH STREET
PROVIDENCE, RHODE ISLAND 02908
401-273-6600

REVISIONS

No.	DATE	DRWN	CHKD
1	1-22-24	TB	TB
2	2-28-24	TB	TB
3	4-2-24	TB	TB
4	4-18-24	TB	TB

SURVEY PLAN
for
PLAT 33, LOT 24
in
SOUTH KINGSTOWN, RHODE ISLAND
SURVEY PLAN

SCALE: 1"=60'	SHEET NO: 1 of 1
DRAWN BY: TB	DESIGN BY: TB
DATE: 02/16/23	CHECKED BY: TB
PROJECT NO.: P22001.00	

LANDSCAPE PLANS

THE VILLAGE AT BROAD ROCK

LOCATED AT:

852 Broad Rock Road
Assessor's Plat 33, Lot 24
South Kingstown, Rhode Island

PREPARED FOR THE:

NEW ENGLAND PROPERTIES, LLC

257 Wickford Court
North Kingstown, Rhode Island 02852

SHEET INDEX

NUMBER	TITLE	ISSUED FOR REVIEW	ISSUED FOR PERMITTING	REVISIONS
	COVER SHEET			
1	OVERALL LANDSCAPE PLAN	11-18-2024		
2	LANDSCAPE PLAN - ENTRANCE	11-18-2024		
3	LANDSCAPE PLAN - INFILTRATION POND	11-18-2024		
4	LANDSCAPE PLAN - CUL-DE-SAC	11-18-2024		
5	LANDSCAPE NOTES & DETAILS	11-18-2024		

PREPARED BY:

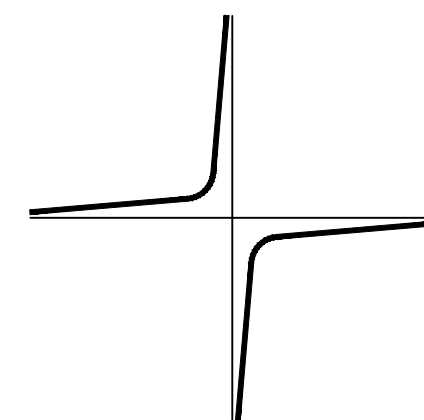

JOHN C. CARTER & CO., INC.

960 BOSTON NECK RD., NARRAGANSETT, RI
(401) 783 - 3500

**LANDSCAPE ARCHITECTURE
DESIGN & BUILD**

- NOTES:**
- GENERAL:**
1. THE EXISTING SITE INFORMATION WAS TAKEN FROM A PLAN PREPARED BY COMMONWEALTH ENGINEERS & CONSULTANTS, TITLED 23011.00 PRELIMINARY PLAN SET-04-06-24, DATED SEPTEMBER 6, 2024, AND FROM OBSERVATIONS PERFORMED BY JOHN C. CARTER & CO.
 2. ANY PROPERTY LINES DEPICTED ON THIS PLAN ARE PICTORIAL ONLY. THIS PLAN IS TO BE USED FOR THE SELECTION, LOCATION AND INSTALLATION OF LANDSCAPE MATERIALS ONLY AND IS NOT TO BE USED FOR ANY OTHER PURPOSE. ALL FOUNDATIONS, RETAINING WALLS AND DRAINAGE COMPONENTS SHALL BE STAKED OUT BY THE ENGINEER OR SURVEYOR.
 3. WRITTEN DIMENSIONS AND SPECIFICATIONS SHALL TAKE PRECEDENCE OVER SCALED DIMENSIONS.
 4. THE LOCATION OF UTILITIES IF SHOWN ON THIS PLAN ARE APPROXIMATE ONLY. IT IS THE RESPONSIBILITY OF THE CONTRACTOR TO FIELD VERIFY THE LOCATION OF ALL UTILITIES BEFORE ANY EXCAVATION. DIG-SAFE SHALL BE CONTACTED AT LEAST 12 HOURS BEFORE EXCAVATION. DIG-SAFE CAN BE REACHED AT 1-888-344-1293.

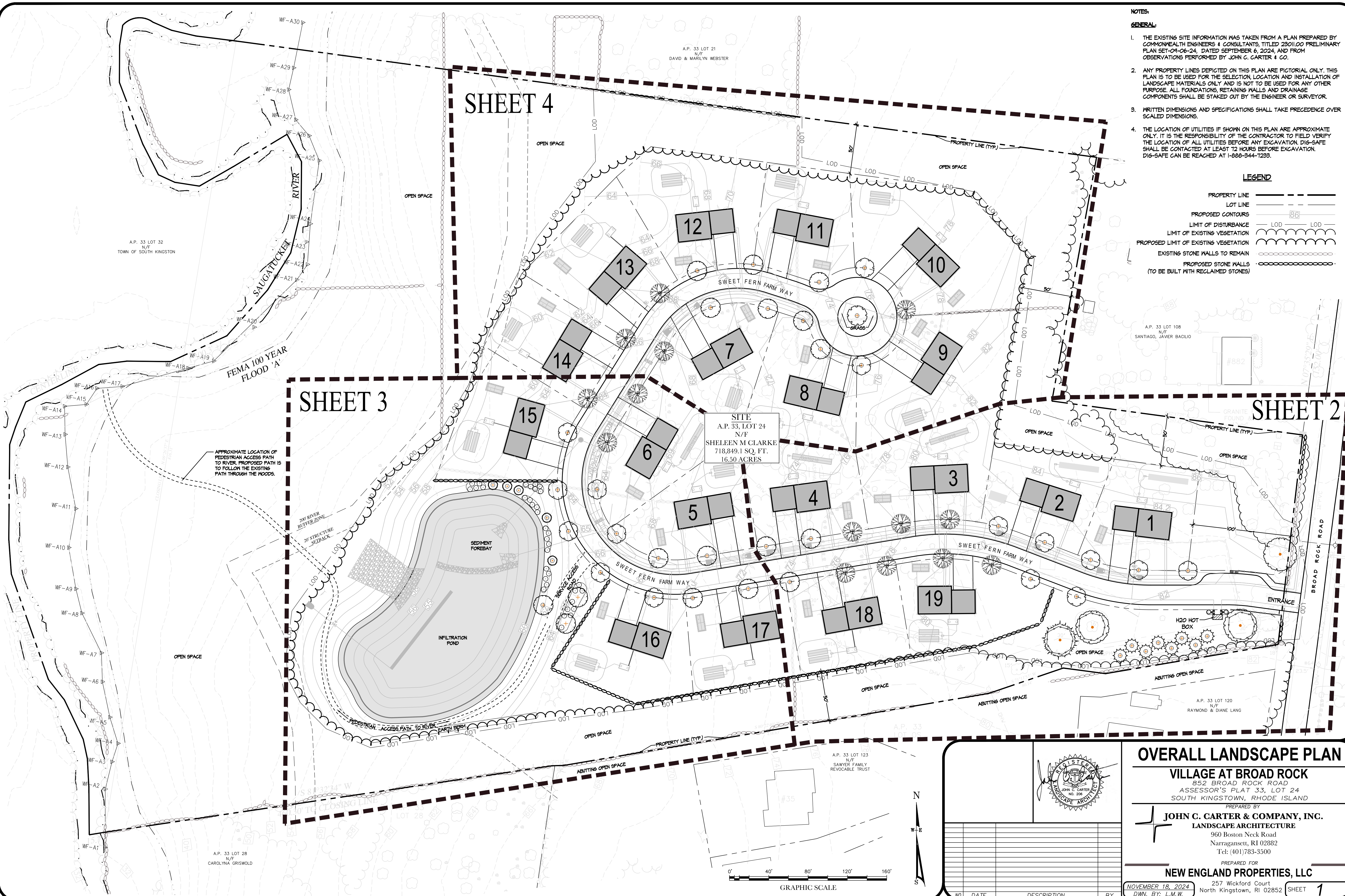
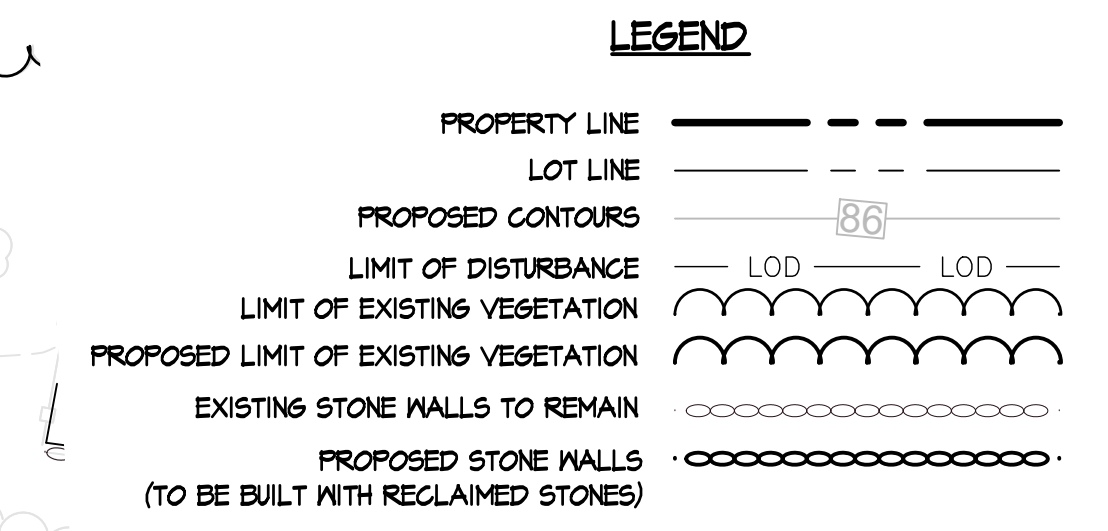

OVERALL LANDSCAPE PLAN

VILLAGE AT BROAD ROCK
 852 BROAD ROCK ROAD
 ASSESSOR'S PLAT 33, LOT 24
 SOUTH KINGSTOWN, RHODE ISLAND

PREPARED BY
JOHN C. CARTER & COMPANY, INC.
 LANDSCAPE ARCHITECTURE
 960 Boston Neck Road
 Narragansett, RI 02882
 Tel: (401)783-3500

REGISTERED LANDSCAPE ARCHITECT
 JOHN C. CARTER
 NO. 296

PREPARED FOR
NEW ENGLAND PROPERTIES, LLC
 257 Wickford Court
 North Kingstown, RI 02852

NOVEMBER 18, 2024
 DWN. BY: L.M.W.

SHEET 1

© COPYRIGHT 2024 JOHN C. CARTER & COMPANY, INC.

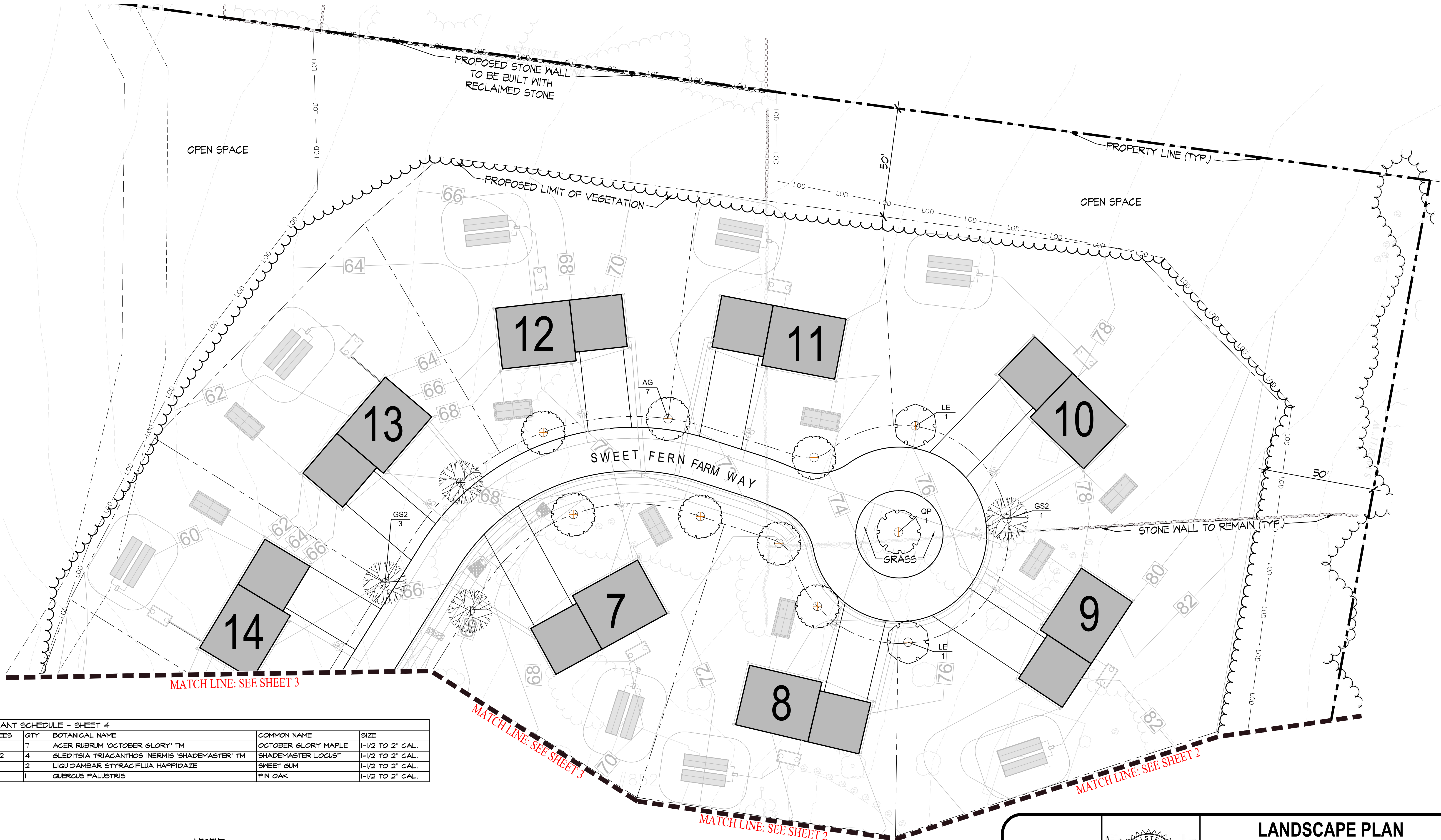

PLANT SCHEDULE - SHEET 4

TREES	QTY	BOTANICAL NAME	COMMON NAME	SIZE
AG	7	ACER RUBRUM 'OCTOBER GLORY'™	OCTOBER GLORY MAPLE	1-1/2 TO 2' CAL.
GS2	4	GLEDITSIA TRIACANTHOS INERMIS 'SHADEMASTER'™	SHADEMASTER LOCUST	1-1/2 TO 2' CAL.
LE	2	LIQUIDAMBAR STYRACIFLUA HAPPIDAZE	SWEET GUM	1-1/2 TO 2' CAL.
QP	1	QUERCUS PALUSTRIS	PIN OAK	1-1/2 TO 2' CAL.

LEGEND

PROPERTY LINE	---
LOT LINE	---
PROPOSED CONTOURS	---
LIMIT OF DISTURBANCE	LOD LOD
LIMIT OF EXISTING VEGETATION	---
PROPOSED LIMIT OF EXISTING VEGETATION	---
EXISTING STONE WALLS TO REMAIN	---
PROPOSED STONE WALLS (TO BE BUILT WITH RECLAIMED STONES)	---

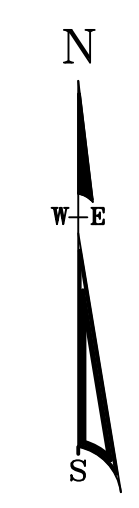
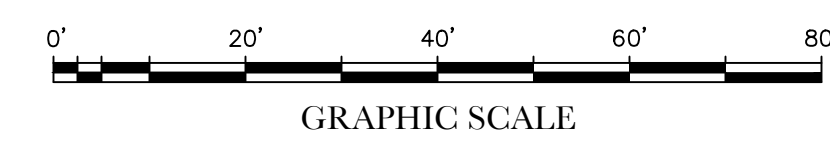

NO.	DATE	DESCRIPTION	BY

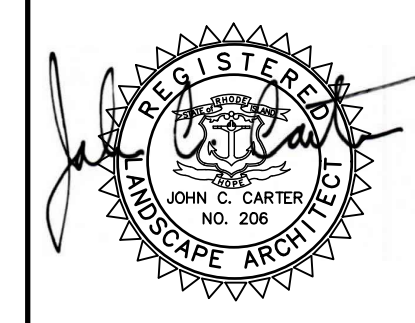

LANDSCAPE PLAN
VILLAGE AT BROAD ROCK
 852 BROAD ROCK ROAD
 ASSESSOR'S PLAT 33, LOT 24
 SOUTH KINGSTOWN, RHODE ISLAND

PREPARED BY
JOHN C. CARTER & COMPANY, INC.
 LANDSCAPE ARCHITECTURE
 960 Boston Neck Road
 Narragansett, RI 02882
 Tel: (401)783-3500

PREPARED FOR
NEW ENGLAND PROPERTIES, LLC
 257 Wickford Court
 North Kingstown, RI 02852

NOVEMBER 18, 2024
 DWN. BY: L.M.W.

SHEET **4**

© COPYRIGHT 2024, JOHN C. CARTER & COMPANY, INC.

