

SITE
 AP 16 BLOCK 4 LOT 9
 N/F
 OLD NORTH LAND INVESTMENTS, LLC
 AREA:
 (118.60± ACRES)
 SUITABLE AREA:
 (61.83± ACRES)
 ZONE R40

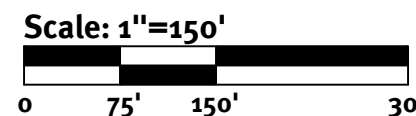

Legend:

| | | | |
|------------------------|-------|------------------------|-----------------|
| ASSESSOR'S LINES | --- | SOIL IDENTIFICATION | BoC |
| PROPERTY LINE | --- | EXISTING STONEWALL | ----- |
| SOIL BOUNDARY LINE | --- | EXISTING BUILDING | ▒ |
| WETLAND EDGE | --- | EXISTING UTILITY POLE | ○ |
| 100' RIVERBANK WETLAND | --- | EXISTING MAJOR CONTOUR | --- 240 --- |
| 50' PERIMETER WETLAND | --- | EXISTING MINOR CONTOUR | --- 242 --- |
| 200' RIVERBANK WETLAND | --- | AP | ASSESSOR'S PLAT |
| EXISTING TREELINE | ~~~~~ | UP | UTILITY POLE |
| EXISTING STREAM | --- | N/F | NOW OR FORMERLY |
| EXISTING FENCE | --- | WETLAND FLAG | ● A5 |
| | | WETLAND HATCH | ▨ |

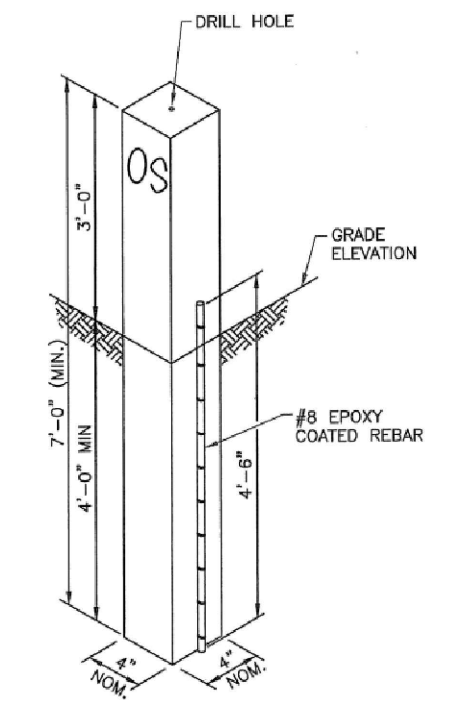

NOTES:
 1. SHALL BE IN ACCORDANCE WITH SECTION 1.15 OF THE TSK STANDARD SPECIFICATIONS.
 2. SHALL BE 4" x 4" PRESSURE TREATED TIMBER.
 3. TOP SURFACE OF BOUND TO BE SAWED SQUARE.
 4. CONICAL DRILL HOLE IN CENTER OF TOP TO BE 1/4" AND 3/4" DEEP.
 5. ROUTERED LETTERS "OS" SHALL APPEAR ON OPPOSITE SIDES AND BE 2" x 3".

MARKER DETAIL