



April 1, 2022

Town of South Kingstown
 Planning Department
 180 High Street
 Wakefield, RI 02879

Attn: Mr. James D. Rabbitt, AICP, Planning Director
 E: jrabbitt@southkingstownri.com

Re: Developmental Review - The Prout School
 Planning Department Approval Dated December 18, 2018
 Gale JN 715792

Dear Mr. Rabbitt:

Gale Associates, Inc. (Gale) is the Engineer of Record for the proposed construction of a multi-purpose synthetic turf athletic field approved by the Planning Board on December 18, 2018. We have reviewed the construction progress to date and can provide the following information:

The Pre-Packaged Sports Lighting System submitted by the contractor was reviewed relative to the Project Bid Specifications, *Section 26 56 68, Exterior Lighting, Part 3 - Pre-Packaged Athletic Lighting Systems* of the "Athletic Campus Renovations, The Prout School", dated August 7, 2019, by Gale. In pertinent part, the specifications include performance standards relative to spill light to adjacent properties, as follows:

3.3 ENVIRONMENTAL LIGHT CONTROL

- A. *Light Control Luminaires: All luminaires shall utilize spill light and glare control devices including, but not limited to, internal shields, louvers and external shields. No symmetrical beam patterns are accepted.*
- B. *Spill Light and Glare Control: To minimize impact on adjacent properties, spill light and candela values must not exceed the following.*

<i>Measured 150' From Field Average</i>	<i>Average</i>
<i>Vertical Footcandles</i>	<i>< ½ FC</i>
<i>Horizontal Footcandles</i>	<i>< ½ FC</i>

- C. *Spill Scans: Spill scans must be submitted indicating the amount of horizontal and vertical footcandles along the specified lines. Light levels shall be taken at 30-foot intervals along the boundary line. Readings shall be taken with the meter orientation at both horizontal and aimed towards the most intense bank of lights. Illumination level shall be measured in accordance with the IESNA LM-5-04 after 1 hour warm up.*
- D. *The first page of a photometric report for all luminaire types proposed showing horizontal and vertical axial candle power shall be provided to demonstrate the capability of*



achieving the specified performance. Reports shall be certified by a qualified independent testing laboratory with a minimum of five years' experience or by a manufacturer's laboratory with a current accreditation under the National Voluntary Laboratory Accreditation Program for Energy Efficient Lighting Products. A summary of the horizontal and vertical aiming angles for each luminaire shall be included with the photometric report.

Light spill is shown on a photometric plan and is impacted by a combination of factors, including, but not limited to, luminaire characteristics, quantity, grouping, arrangement, mounting height, and pole location, as well as the topography and objects to be illuminated. Because of this, photometric plans can only be produced using specific luminaires. As such, a photometric plan is submitted by the contractor as part of the Pre-Packaged Sports Lighting System submittal.

Gale has reviewed the Pre-Packaged Sports Lighting System submitted by the contractor, including a photometric plan, and found them in substantial compliance with the performance requirements of the *Section 26 56 68, Exterior Lighting, Part 3 - Pre-Packaged Athletic Lighting Systems* of the "Athletic Campus Renovations, The Prout School" Bid Specifications, dated August 7, 2019, by Gale (review attached).

Gale has reviewed the four (4) proposed light pole locations, as surveyed by Geisser Engineering, Inc., on March 24, 2022, and finds them to be substantially located as shown on the approved design plans. The as-built light pole locations are shown on a plan entitled "Light Pole As-Built Location Plan" by Gale, dated March 25, 2022 (attached). As a point of reference, Tower Hill Road (U.S. Route 1) is greater than 450 feet from the nearest Pre-Packaged Sports Lighting System pole.

Best regards,

A handwritten signature in blue ink that reads "Bree Sullivan". The signature is written in a cursive, flowing style.

GALE ASSOCIATES, INC.
Bree D. Sullivan, P.E. (RI #14166)
Chief Civil Engineer

BDS/cmh

Enclosures:

- Pre-Packaged Sports Lighting System Review
- Light Pole As-Built Location Plan

CC:

- Travis McDermott tmcdermott@psh.com
- Jason Pannone jpannone@bentleycompanies.com
- Donna Nardone dnardone@theproutschool.org
- Gary Ferguson gferguson@dioceseofprovidence.org
- David Estes destes@theproutschool.org
- Jon Lindberg jfl@gainc.com
- Peter Spanos ps@gainc.com



GALE ASSOCIATES, INC.

Review is only for conformance with the design concept of the project and for compliance with the information given in the Contract Documents. The Contractor is responsible for dimensions and quantities to be confirmed and correlated at the site, for information that pertains to the fabrication process or to the means, methods, techniques, sequences and procedures of construction, and for the coordination of the work of all trades. The review and approval of a specific item shall not indicate approval of an assembly of which the item is a component.

- Approved
- Approved as Noted
- Revise and Resubmit
- Disapproved
- Received for Record

Submittal Number/Package 265668-1.1 Date Received 10/22/2021

Reviewed By Bree Sullivan Date Reviewed 10/29/2021

Section	Product	Status	Comment
26 56 68	Part 3 Pre-Packaged Sports lighting Systems	Approved as Noted	Manufacturer shall provide lightning grounding as defined by NFPA 780 and be UL Listed per UL 96 and UL 96A in accordance with Section 3.5.C.9

*** All of the backup needs to be attached to the submittal stamp for record and future reference.

N:\715792\04 Construction\submittals\Submittal Review Stamp.docx

TECHLINE
SPORTS LIGHTING

POWERED BY
GEOSPORT



PROUT SCHOOL

Wakefield, RI

Multi-Purpose Field

Mark Reynolds: 512-825-0839

Rep Agency Partner:	Bentley Builders, LLC Proposal
Project Name:	Prout School
Project City-State:	Wakefield, Rhode Island
Quote Date:	8/24/2021
Type of Field(s):	MULTI PURPOSE - 330' x 195'
Photometrics Per Design #:	50FC Avg. Light Level / Design #21-3330
Type of Field(s):	**ALL POLES RATED FOR 120mph AASHTO Wind Speeds**
Warranty:	Includes Our 25-Year Maintenance Free Warranty

Quantity	Description
4	70 Foot Mounting Height Steel Poles
4	16 Fixture Crossarms
64	CLIR 630w LED w/ Visor
64	CLIR 20" Extended Visor
64	Prewiring for Poles and Crossarms
1	Standard Wireless Control Hub
1	25 Year LED Fixture Warranty

<p>Project Notes:</p> <ul style="list-style-type: none"> ➤ Price includes all materials listed above (excluding adders & deducts). ➤ Price includes freight / delivery to jobsite. ➤ Price firm for 30 days. ➤ Allow 2-3 weeks for delivery. ➤ Price does NOT include SALES or USE taxes. ➤ All work to be performed that requires a license, including but not limited to electrical & plumbing will be performed by individuals currently licensed in the proper jurisdiction.
--

<p>Warranty Notes:</p> <ul style="list-style-type: none"> ➤ Seller warrants that Equipment furnished or manufactured by Seller will be free from defects in material and workmanship for a period - of <u>25 years</u> from date of shipment. ➤ Seller will replace any defective material for the entire <u>25 year</u> period. ➤ Techline will make every effort to maintain any component of our sports lighting system for the entirety of the warranty period.

<p>(-) DEDUCT ALTERNATE:</p> <ul style="list-style-type: none"> ➤ To REMOVE... To include our 10-Year Maintenance Free Warranty in lieu of a 25-Year Warranty.....
--

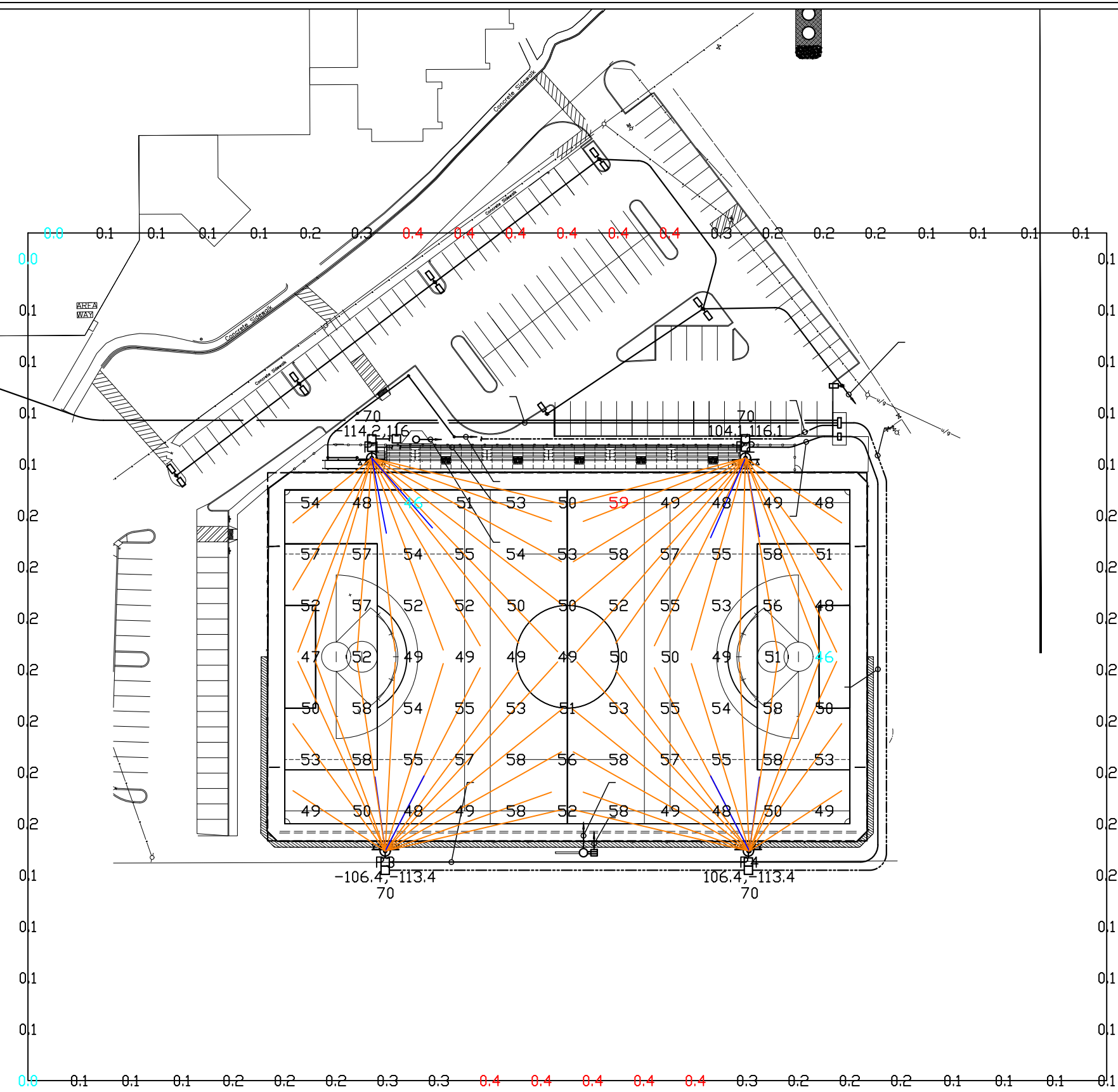

Pole	x-loc	y-loc	height	M	EW	Total	kw
P1	-114.2	116	70ft	14	2	16	10.3
P2	104.1	116.1	70ft	14	2	16	10.3
P3	-106.4	-113.4	70ft	14	2	16	10.3
P4	106.4	-113.4	70ft	14	2	16	10.3
Total				56	8	64	41.3

Soccer 330'X195'
 77 points at z=3, sp 30ft by 30ft
 HORIZONTAL FOOTCANDLES
 Average 53
 Maximum 59
 Minimum 46
 Avg:Min 1.14
 Max:Min 1.28
 Coef Var 0.07
 UnifGrad 1.20

EW
 CLIR 630 EV EW
 Light Loss Factor = 0.950
 Watts per luminaire = 646
 Number luminaires used = 8
 kw these luminaires = 5.2

Spill 150'
 75 points at z=3, sp 15ft by 15ft
 HORIZONTAL FOOTCANDLES
 Average 0.2
 Maximum 0.4
 Minimum 0.0
 Avg:Min N/A
 Max:Min N/A
 Coef Var 0.59
 UnifGrad 7070.36

M
 CLIR 630 EV M
 Light Loss Factor = 0.950
 Watts per luminaire = 646
 Number luminaires used = 56
 kw these luminaires = 36.2

**PROUT SCHOOL
 WAKEFIELD, RI
 SOCCER**

1. THIS LIGHTING DESIGN IS BASED ON INFORMATION SUPPLIED BY OTHERS. SITE DETAILS PROVIDED HEREON ARE REPRODUCED ONLY AS A VISUALIZATION AID. FIELD DEVIATIONS MAY SIGNIFICANTLY AFFECT PREDICTED PERFORMANCE. PRIOR TO INSTALLATION, CRITICAL SITE INFORMATION (POLE LOCATIONS, ORIENTATION, MOUNTING HEIGHT, ETC.) SHOULD BE COORDINATED WITH THE CONTRACTOR AND/OR SPECIFIER RESPONSIBLE FOR THE PROJECT.
 2. LUMINAIRE DATA IS TESTED TO INDUSTRY STANDARDS UNDER LABORATORY CONDITIONS. OPERATING VOLTAGE AND NORMAL MANUFACTURING TOLERANCES OF LAMP, BALLAST, AND LUMINAIRE MAY AFFECT FIELD RESULTS.
 3. CONFORMANCE TO FACILITY CODE AND OTHER LOCAL REQUIREMENTS IS THE RESPONSIBILITY OF THE OWNER AND/OR THE OWNER'S REPRESENTATIVE.
 4. CALCULATIONS DO NOT TAKE INTO CONSIDERATION ANY OBSTRUCTIONS OR LIGHTING POLLUTION CAUSED BY NEIGHBORING LIGHT SOURCES.

P1
-114.2,116

P2
104.1,116.1

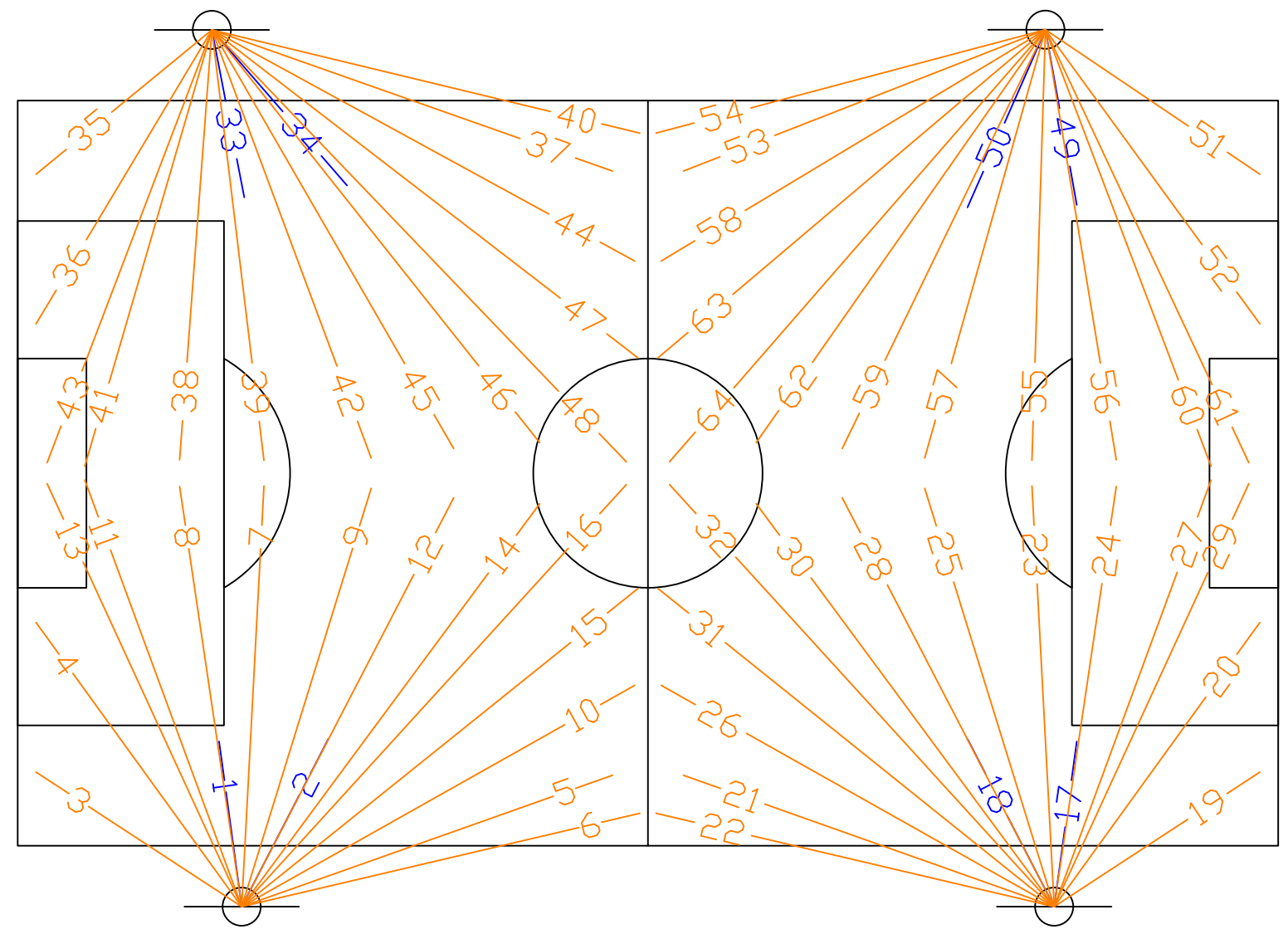

P3
-106.4,-113.4

P4
106.4,-113.4

Prout HS Soccer AIMING
*AS VIEWED FROM BEHIND THE POLE



PROUT SCHOOL
WAKEFIELD, RI
SOCCER

1. THIS LIGHTING DESIGN IS BASED ON INFORMATION SUPPLIED BY OTHERS. SITE DETAILS PROVIDED HEREON ARE REPRODUCED ONLY AS A VISUALIZATION AID. FIELD DEVIATIONS MAY SIGNIFICANTLY AFFECT PREDICTED PERFORMANCE. PRIOR TO INSTALLATION, CRITICAL SITE INFORMATION (POLE LOCATIONS, ORIENTATION, MOUNTING HEIGHT, ETC.) SHOULD BE COORDINATED WITH THE CONTRACTOR AND/OR SPECIFIER RESPONSIBLE FOR THE PROJECT.
2. LUMINAIRE DATA IS TESTED TO INDUSTRY STANDARDS UNDER LABORATORY CONDITIONS. OPERATING VOLTAGE AND NORMAL MANUFACTURING TOLERANCES OF LAMP, BALLAST, AND LUMINAIRE MAY AFFECT FIELD RESULTS.
3. CONFORMANCE TO FACILITY CODE AND OTHER LOCAL REQUIREMENTS IS THE RESPONSIBILITY OF THE OWNER AND/OR THE OWNER'S REPRESENTATIVE.
4. CALCULATIONS DO NOT TAKE INTO CONSIDERATION ANY OBSTRUCTIONS OR LIGHTING POLLUTION CAUSED BY NEIGHBORING LIGHT SOURCES.

DRAWN BY:JCIE
Date:10/19/2021
SCALE:NTS
Page:1 of 5
Dwg #:21-3330-AIM

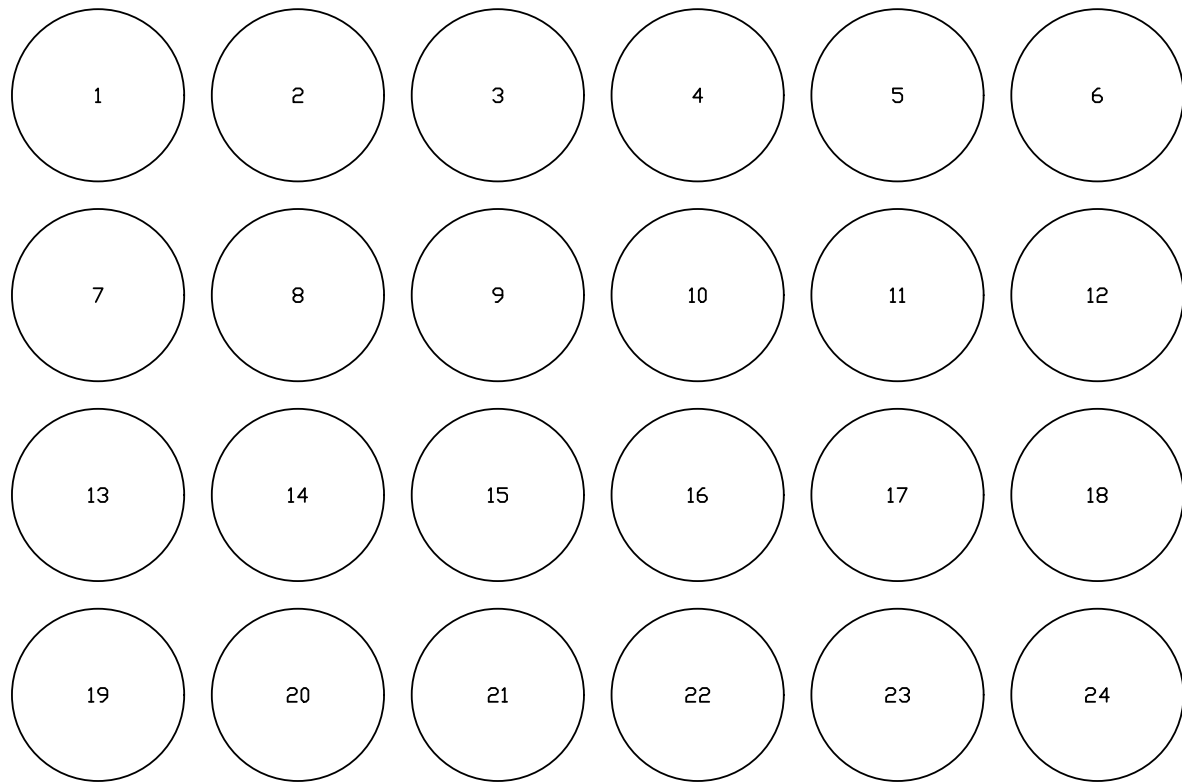

pole P1
base xyz= 48,-65,0 : height= 70ft

VIEW FROM BEHIND THE POLE

FIXTURES AIMED TOWARDS FIELD OF PLAY

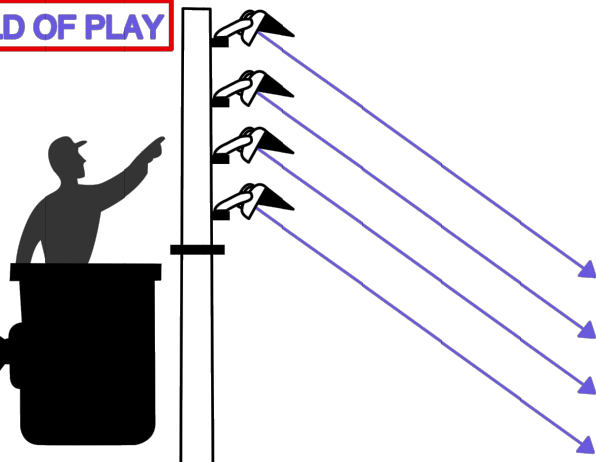
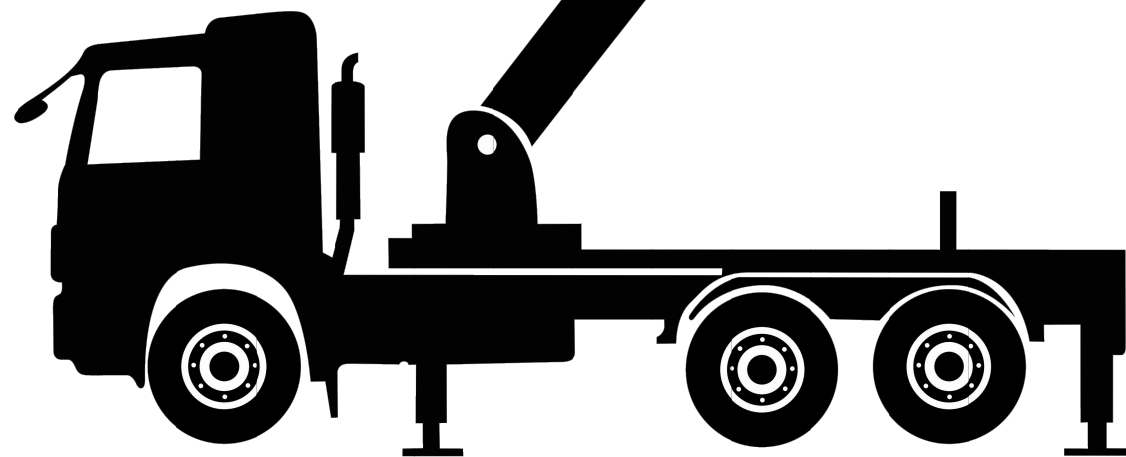

**FIXTURE AIMING
POINT OF VIEW
DIAGRAM**

1. THIS LIGHTING DESIGN IS BASED ON INFORMATION SUPPLIED BY OTHERS. SITE DETAILS PROVIDED HEREON ARE REPRODUCED ONLY AS A VISUALIZATION AID. FIELD DEVIATIONS MAY SIGNIFICANTLY AFFECT PREDICTED PERFORMANCE. PRIOR TO INSTALLATION, CRITICAL SITE INFORMATION (POLE LOCATIONS, ORIENTATION, MOUNTING HEIGHT, ETC.) SHOULD BE COORDINATED WITH THE CONTRACTOR AND/OR SPECIFIER RESPONSIBLE FOR THE PROJECT.
2. LUMINAIRE DATA IS TESTED TO INDUSTRY STANDARDS UNDER LABORATORY CONDITIONS. OPERATING VOLTAGE AND NORMAL MANUFACTURING TOLERANCES OF LAMP, BALLAST, AND LUMINAIRE MAY AFFECT FIELD RESULTS.
3. CONFORMANCE TO FACILITY CODE AND OTHER LOCAL REQUIREMENTS IS THE RESPONSIBILITY OF THE OWNER AND/OR THE OWNER'S REPRESENTATIVE.
4. CALCULATIONS DO NOT TAKE INTO CONSIDERATION ANY OBSTRUCTIONS OR LIGHTING POLLUTION CAUSED BY NEIGHBORING LIGHT SOURCES.

DRAWN BY: JCLA
SCALE: NTS

FIELD OF PLAY

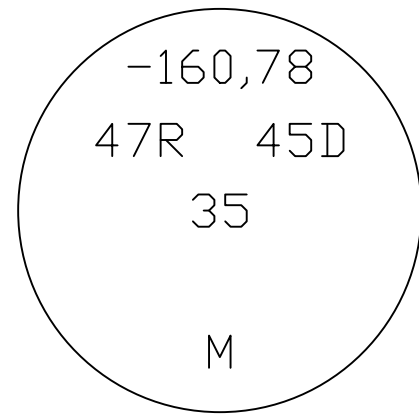
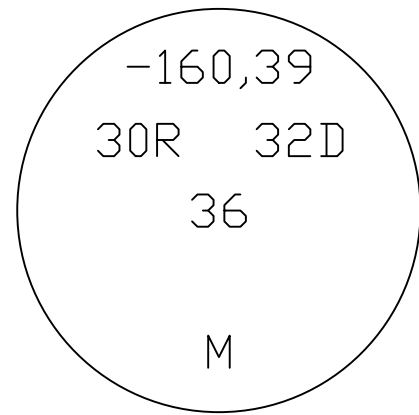
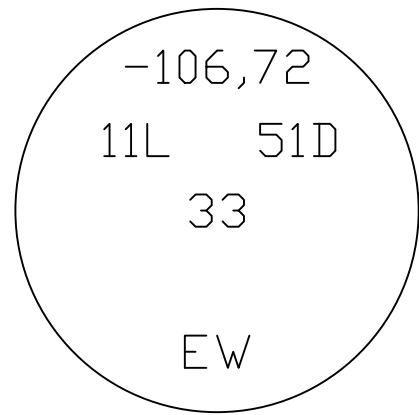
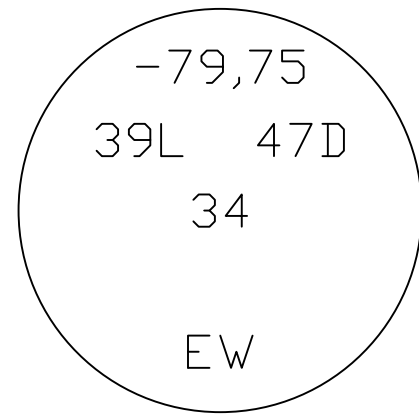
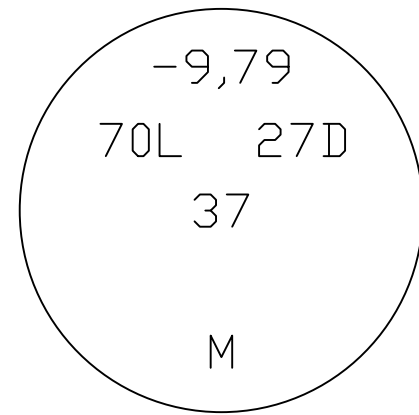
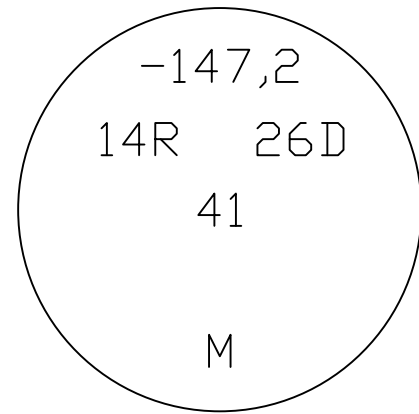
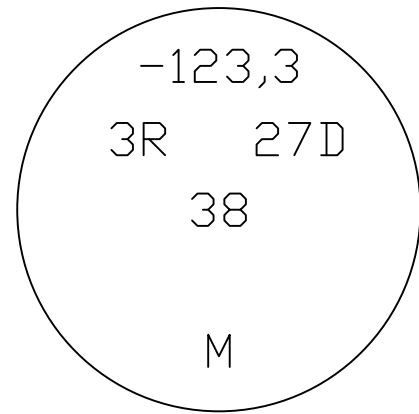
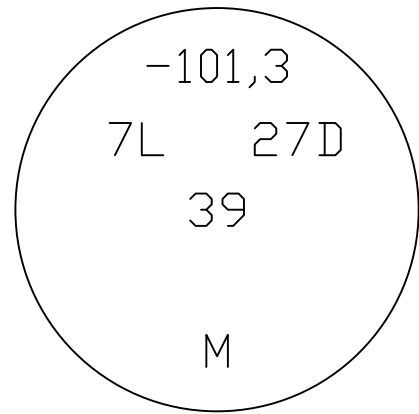
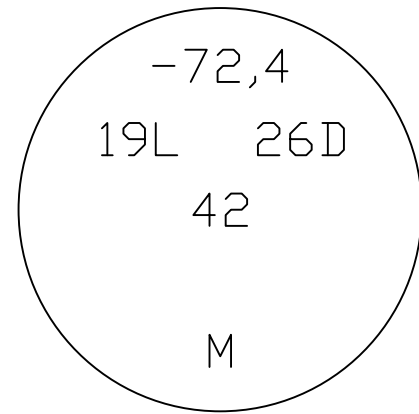
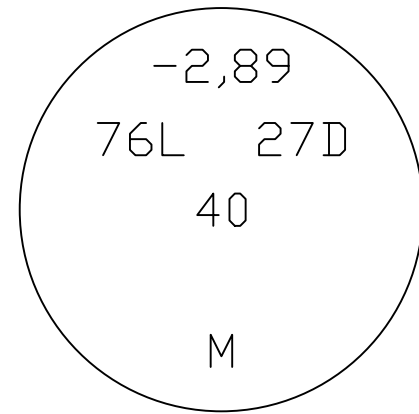
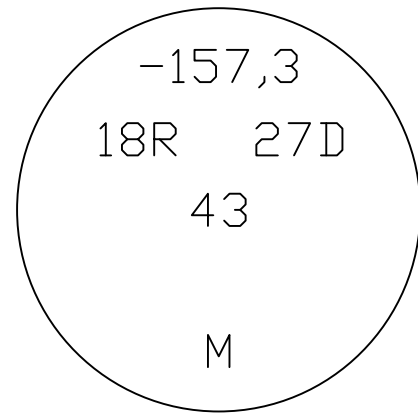
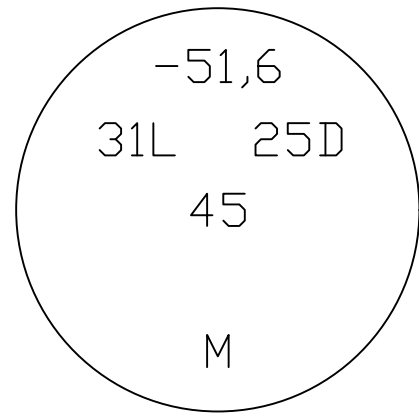
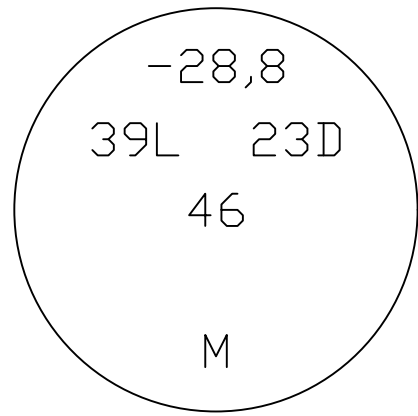
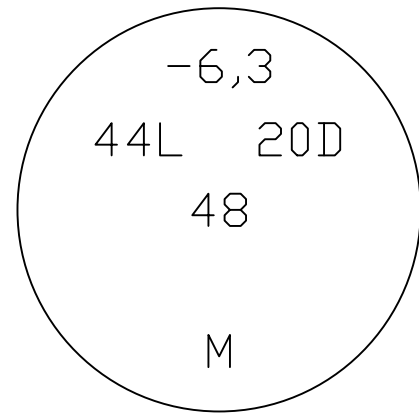
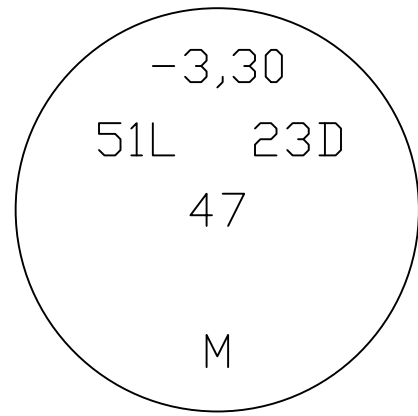
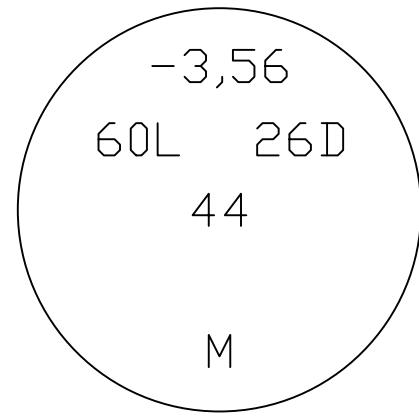

pole P1
base xyz= -114.2,116,0 : height= 70ft

VIEW FROM BEHIND THE POLE



PROUT SCHOOL
WAKEFIELD, RI
SOCCER

1. THIS LIGHTING DESIGN IS BASED ON INFORMATION SUPPLIED BY OTHERS. SITE DETAILS PROVIDED HEREON ARE REPRODUCED ONLY AS A VISUALIZATION AID. FIELD DEVIATIONS MAY SIGNIFICANTLY AFFECT PREDICTED PERFORMANCE. PRIOR TO INSTALLATION, CRITICAL SITE INFORMATION (POLE LOCATIONS, ORIENTATION, MOUNTING HEIGHT, ETC.) SHOULD BE COORDINATED WITH THE CONTRACTOR AND/OR SPECIFIER RESPONSIBLE FOR THE PROJECT.
2. LUMINAIRE DATA IS TESTED TO INDUSTRY STANDARDS UNDER LABORATORY CONDITIONS. OPERATING VOLTAGE AND NORMAL MANUFACTURING TOLERANCES OF LAMP, BALLAST, AND LUMINAIRE MAY AFFECT FIELD RESULTS.
3. CONFORMANCE TO FACILITY CODE AND OTHER LOCAL REQUIREMENTS IS THE RESPONSIBILITY OF THE OWNER AND/OR THE OWNER'S REPRESENTATIVE.
4. CALCULATIONS DO NOT TAKE INTO CONSIDERATION ANY OBSTRUCTIONS OR LIGHTING POLLUTION CAUSED BY NEIGHBORING LIGHT SOURCES.

DRAWN BY: JCIE
Date: 10/19/2021
SCALE: NTS
Page: 2 of 5
Dwg #: 21-3330-AIM

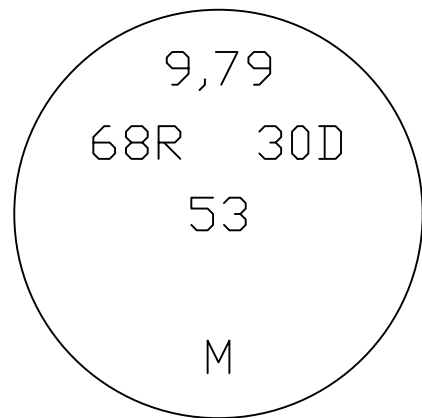
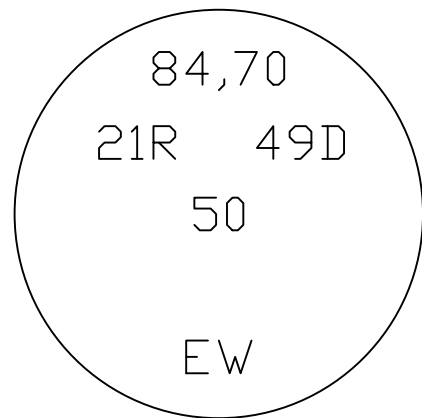
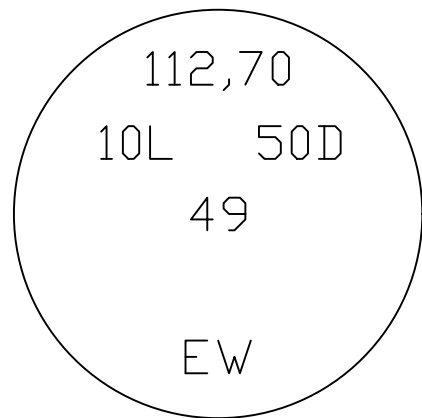
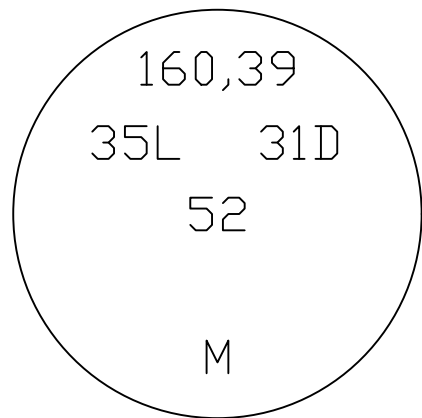
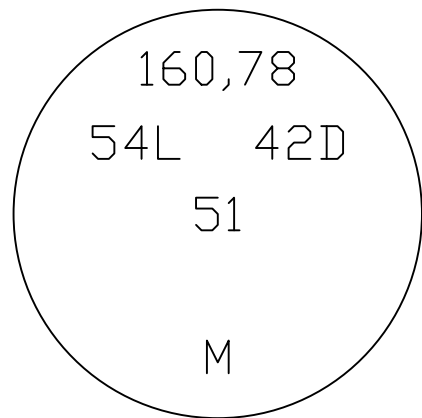
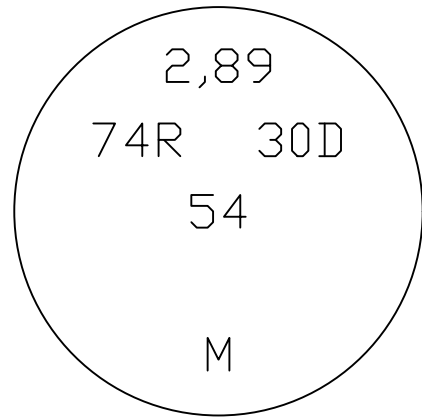
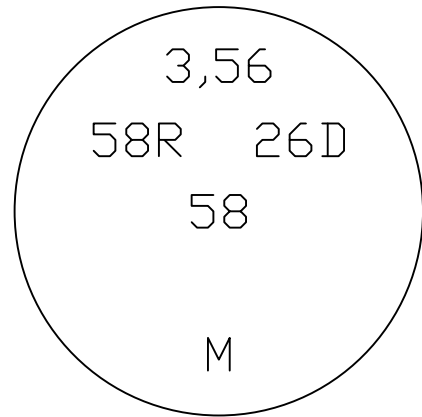
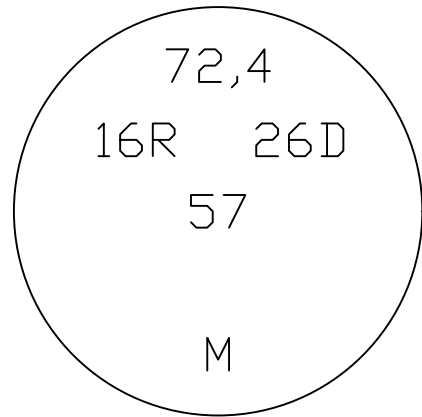
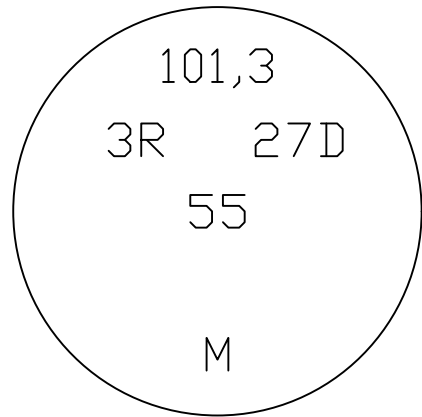
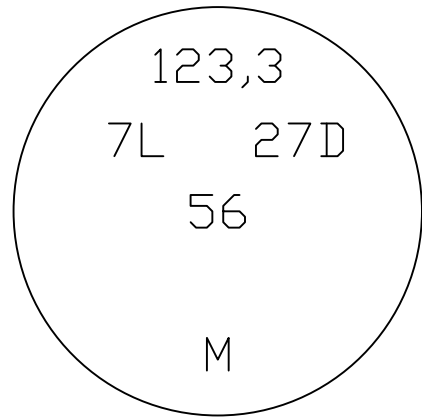
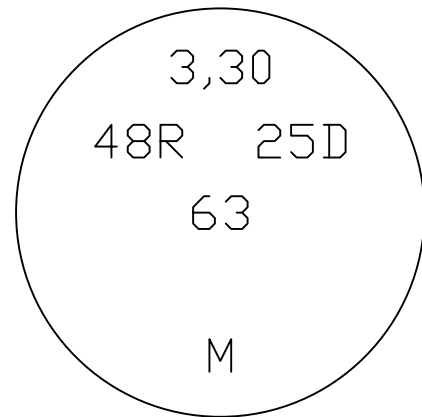
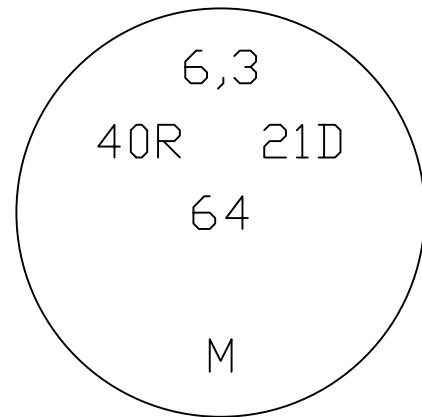
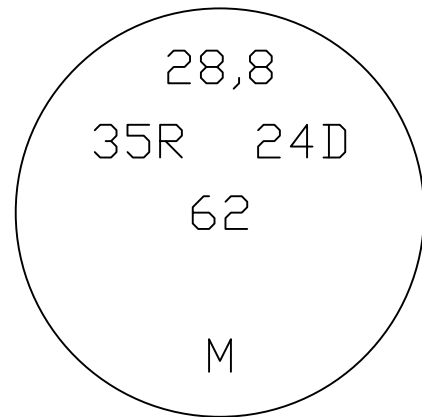
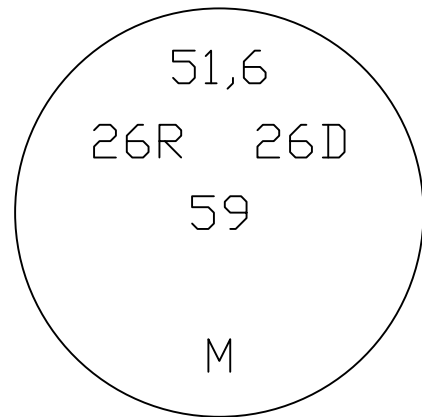
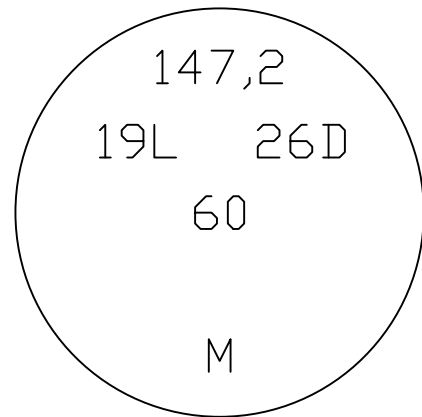
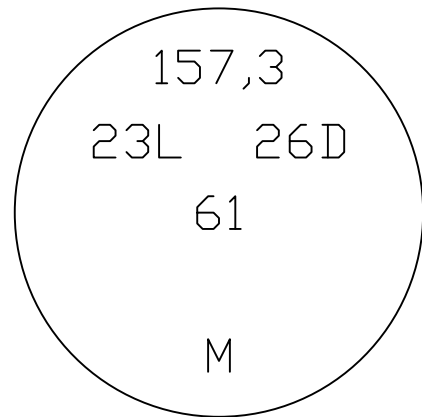

pole P2
base xyz= 104.1,116.1,0 : height= 70ft

VIEW FROM BEHIND THE POLE



PROUT SCHOOL
WAKEFIELD, RI
SOCCER

1. THIS LIGHTING DESIGN IS BASED ON INFORMATION SUPPLIED BY OTHERS. SITE DETAILS PROVIDED HEREON ARE REPRODUCED ONLY AS A VISUALIZATION AID. FIELD DEVIATIONS MAY SIGNIFICANTLY AFFECT PREDICTED PERFORMANCE. PRIOR TO INSTALLATION, CRITICAL SITE INFORMATION (POLE LOCATIONS, ORIENTATION, MOUNTING HEIGHT, ETC.) SHOULD BE COORDINATED WITH THE CONTRACTOR AND/OR SPECIFIER RESPONSIBLE FOR THE PROJECT.
2. LUMINAIRE DATA IS TESTED TO INDUSTRY STANDARDS UNDER LABORATORY CONDITIONS. OPERATING VOLTAGE AND NORMAL MANUFACTURING TOLERANCES OF LAMP, BALLAST, AND LUMINAIRE MAY AFFECT FIELD RESULTS.
3. CONFORMANCE TO FACILITY CODE AND OTHER LOCAL REQUIREMENTS IS THE RESPONSIBILITY OF THE OWNER AND/OR THE OWNER'S REPRESENTATIVE.
4. CALCULATIONS DO NOT TAKE INTO CONSIDERATION ANY OBSTRUCTIONS OR LIGHTING POLLUTION CAUSED BY NEIGHBORING LIGHT SOURCES.

DRAWN BY: JCIE
Date: 10/19/2021
SCALE: NTS
Page: 3 of 5
Dwg #: 21-3330-AIM

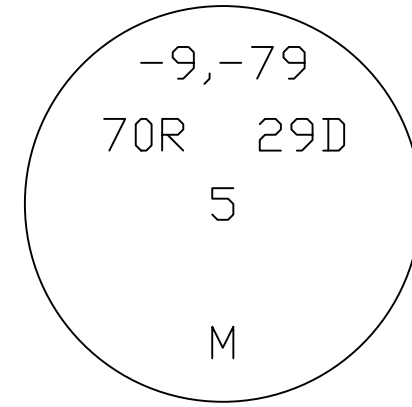
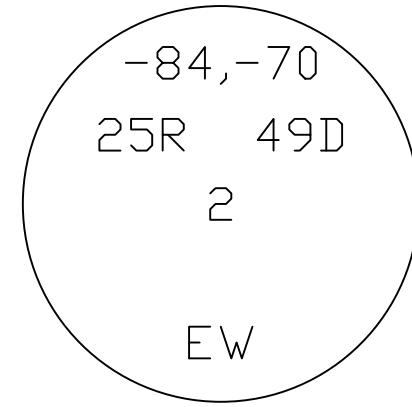
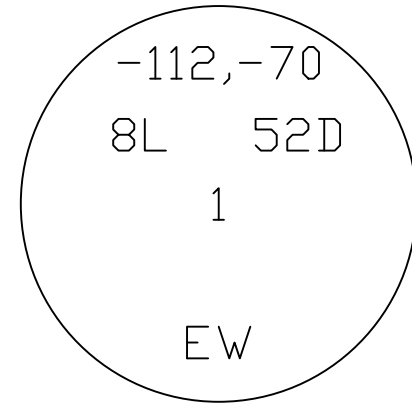
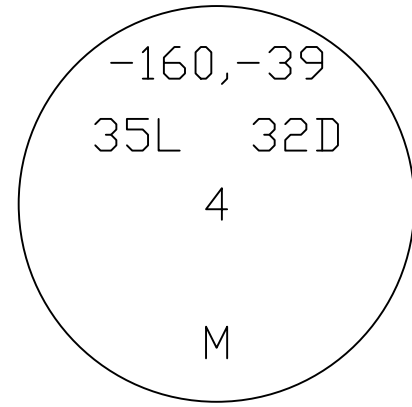
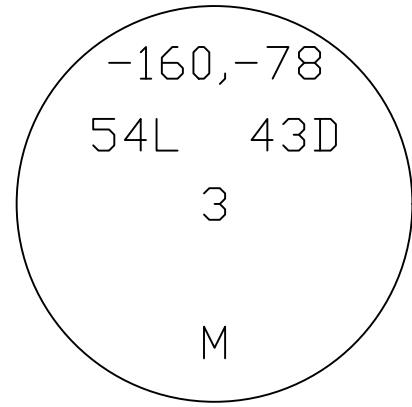
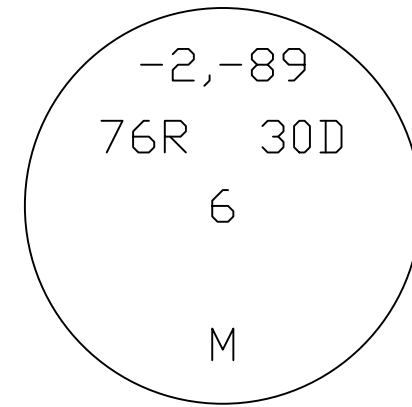
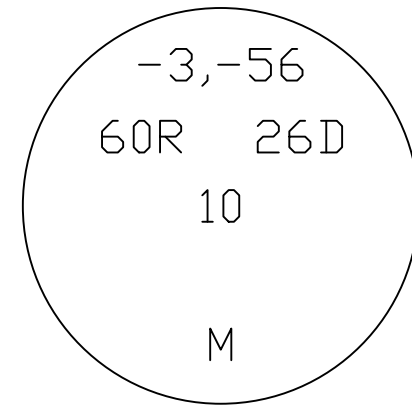
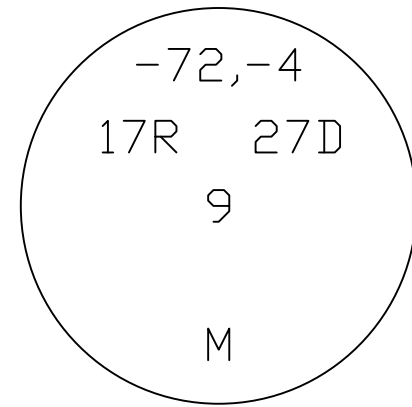
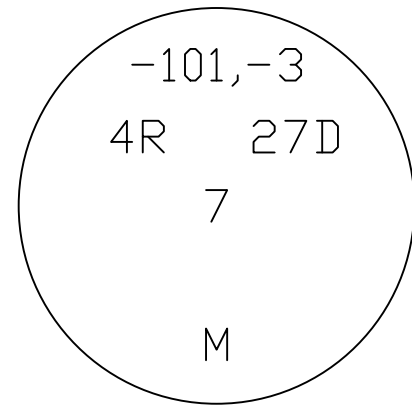
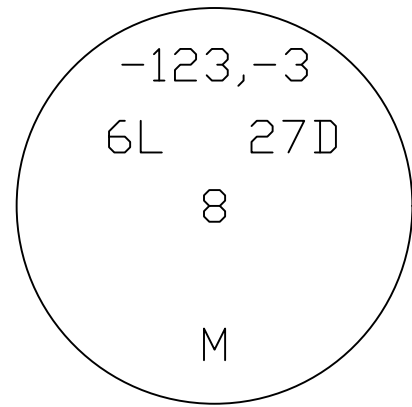
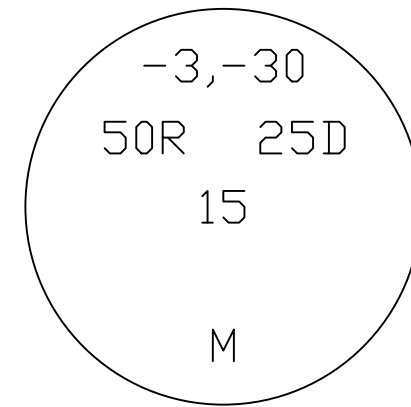
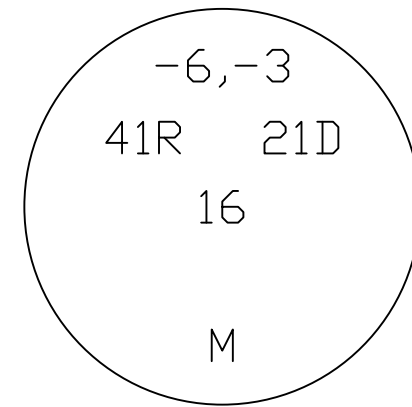
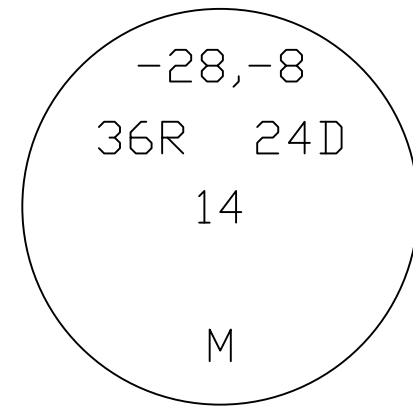
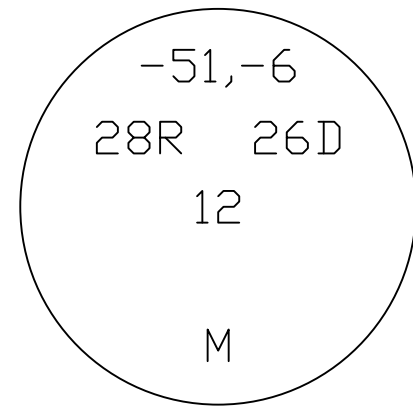
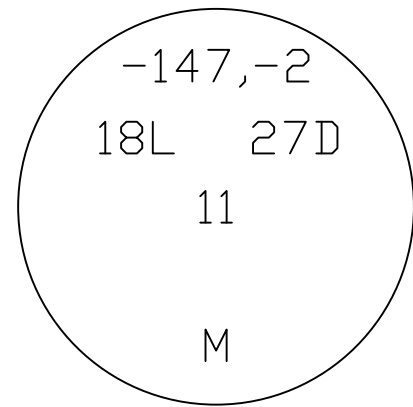
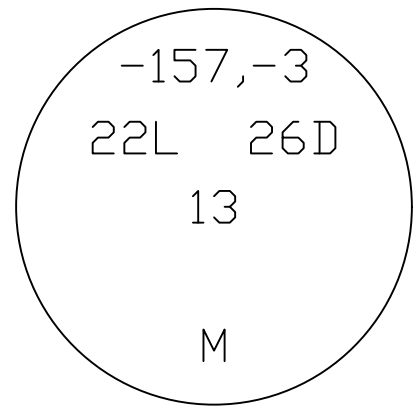

pole P3
base xyz= -106.4,-113.4,0 : height= 70ft

VIEW FROM BEHIND THE POLE



PROUT SCHOOL
WAKEFIELD, RI
SOCCER

1. THIS LIGHTING DESIGN IS BASED ON INFORMATION SUPPLIED BY OTHERS. SITE DETAILS PROVIDED HEREON ARE REPRODUCED ONLY AS A VISUALIZATION AID. FIELD DEVIATIONS MAY SIGNIFICANTLY AFFECT PREDICTED PERFORMANCE. PRIOR TO INSTALLATION, CRITICAL SITE INFORMATION (POLE LOCATIONS, ORIENTATION, MOUNTING HEIGHT, ETC.) SHOULD BE COORDINATED WITH THE CONTRACTOR AND/OR SPECIFIER RESPONSIBLE FOR THE PROJECT.
2. LUMINAIRE DATA IS TESTED TO INDUSTRY STANDARDS UNDER LABORATORY CONDITIONS. OPERATING VOLTAGE AND NORMAL MANUFACTURING TOLERANCES OF LAMP, BALLAST, AND LUMINAIRE MAY AFFECT FIELD RESULTS.
3. CONFORMANCE TO FACILITY CODE AND OTHER LOCAL REQUIREMENTS IS THE RESPONSIBILITY OF THE OWNER AND/OR THE OWNER'S REPRESENTATIVE.
4. CALCULATIONS DO NOT TAKE INTO CONSIDERATION ANY OBSTRUCTIONS OR LIGHTING POLLUTION CAUSED BY NEIGHBORING LIGHT SOURCES.

DRAWN BY: JCIE
Date: 10/19/2021
SCALE: NTS
Page: 4 of 5
Dwg #: 21-3330-AIM

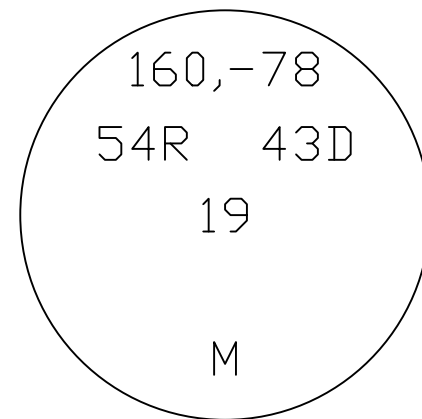
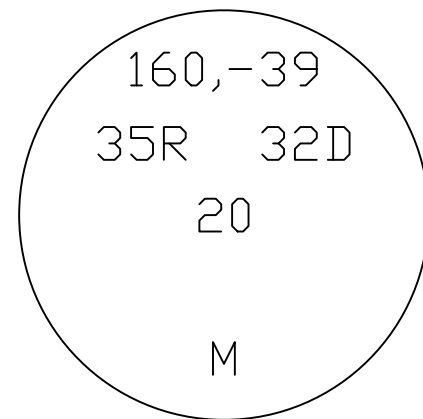
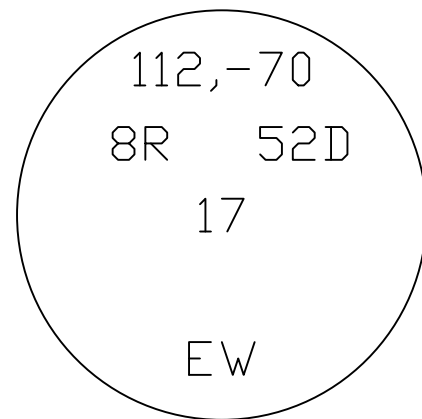
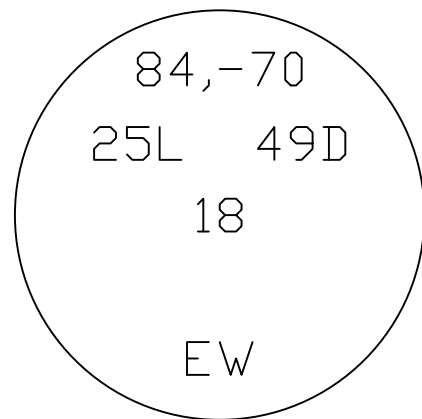
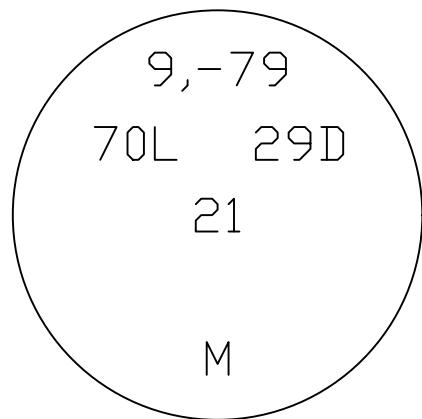
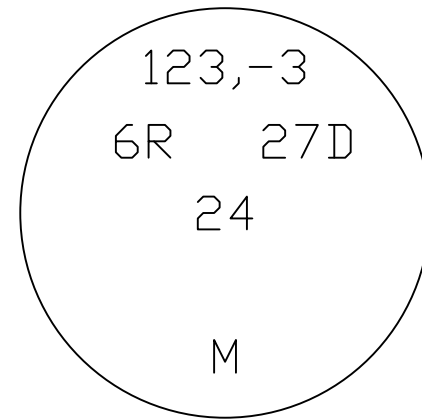
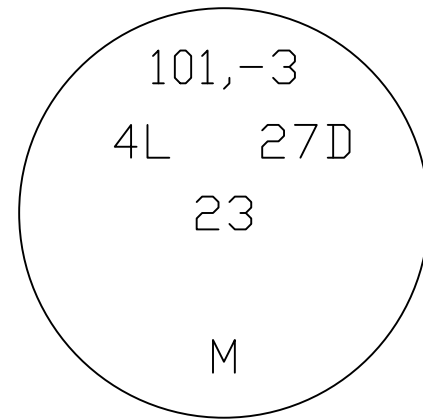
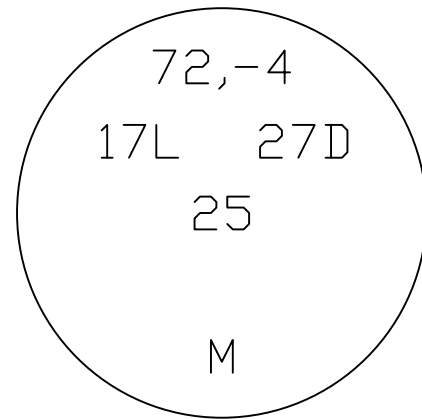
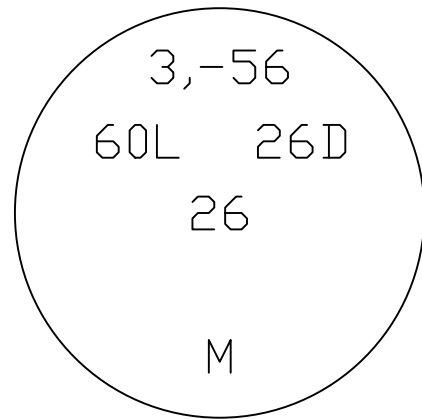
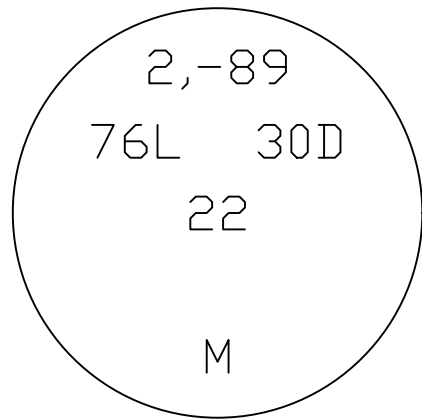
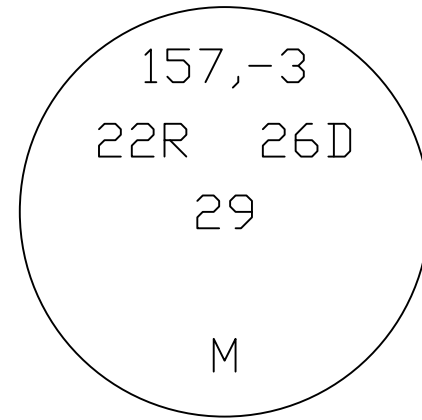
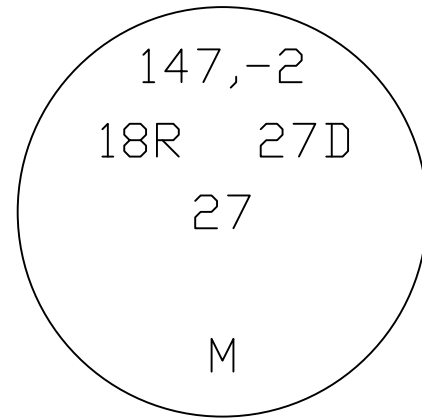
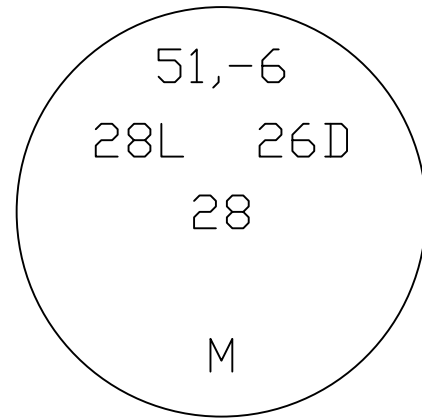
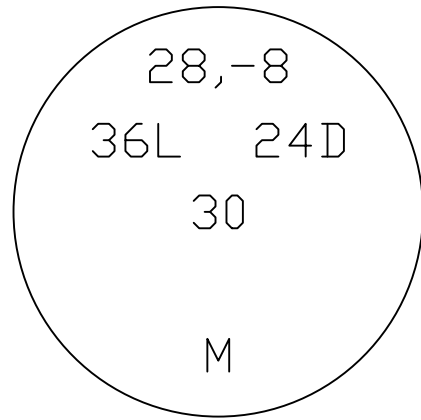
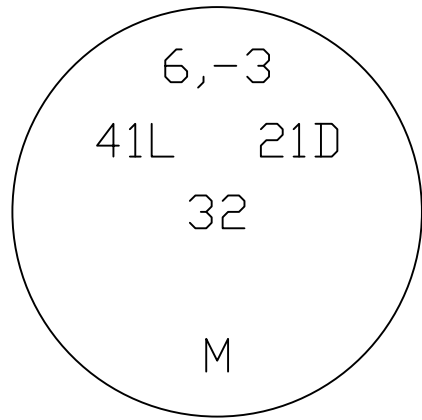
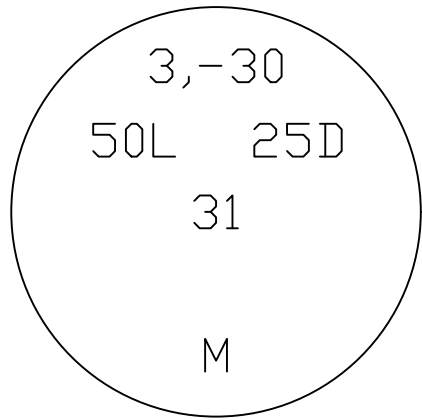

pole P4
base xyz= 106.4,-113.4,0 : height= 70ft

VIEW FROM BEHIND THE POLE



PROUT SCHOOL
WAKEFIELD, RI
SOCCER

1. THIS LIGHTING DESIGN IS BASED ON INFORMATION SUPPLIED BY OTHERS. SITE DETAILS PROVIDED HEREON ARE REPRODUCED ONLY AS A VISUALIZATION AID. FIELD DEVIATIONS MAY SIGNIFICANTLY AFFECT PREDICTED PERFORMANCE. PRIOR TO INSTALLATION, CRITICAL SITE INFORMATION (POLE LOCATIONS, ORIENTATION, MOUNTING HEIGHT, ETC.) SHOULD BE COORDINATED WITH THE CONTRACTOR AND/OR SPECIFIER RESPONSIBLE FOR THE PROJECT.
2. LUMINAIRE DATA IS TESTED TO INDUSTRY STANDARDS UNDER LABORATORY CONDITIONS. OPERATING VOLTAGE AND NORMAL MANUFACTURING TOLERANCES OF LAMP, BALLAST, AND LUMINAIRE MAY AFFECT FIELD RESULTS.
3. CONFORMANCE TO FACILITY CODE AND OTHER LOCAL REQUIREMENTS IS THE RESPONSIBILITY OF THE OWNER AND/OR THE OWNER'S REPRESENTATIVE.
4. CALCULATIONS DO NOT TAKE INTO CONSIDERATION ANY OBSTRUCTIONS OR LIGHTING POLLUTION CAUSED BY NEIGHBORING LIGHT SOURCES.

DRAWN BY: JCIE
Date: 10/19/2021
SCALE: NTS
Page: 5 of 5
Dwg #: 21-3330-AIM

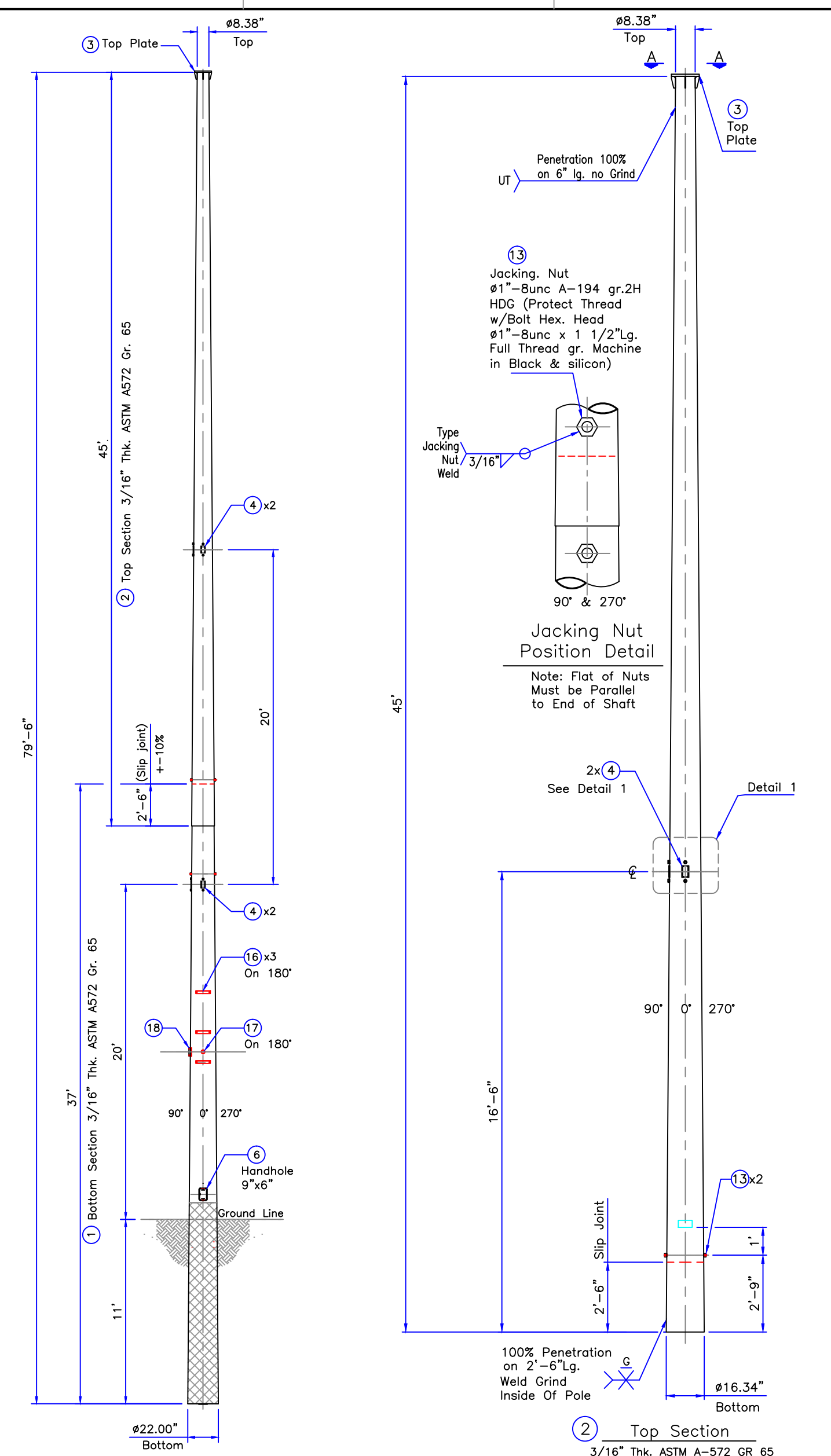

TSL75HA Pole Elevation
Round Tapered Pole 2 Sections

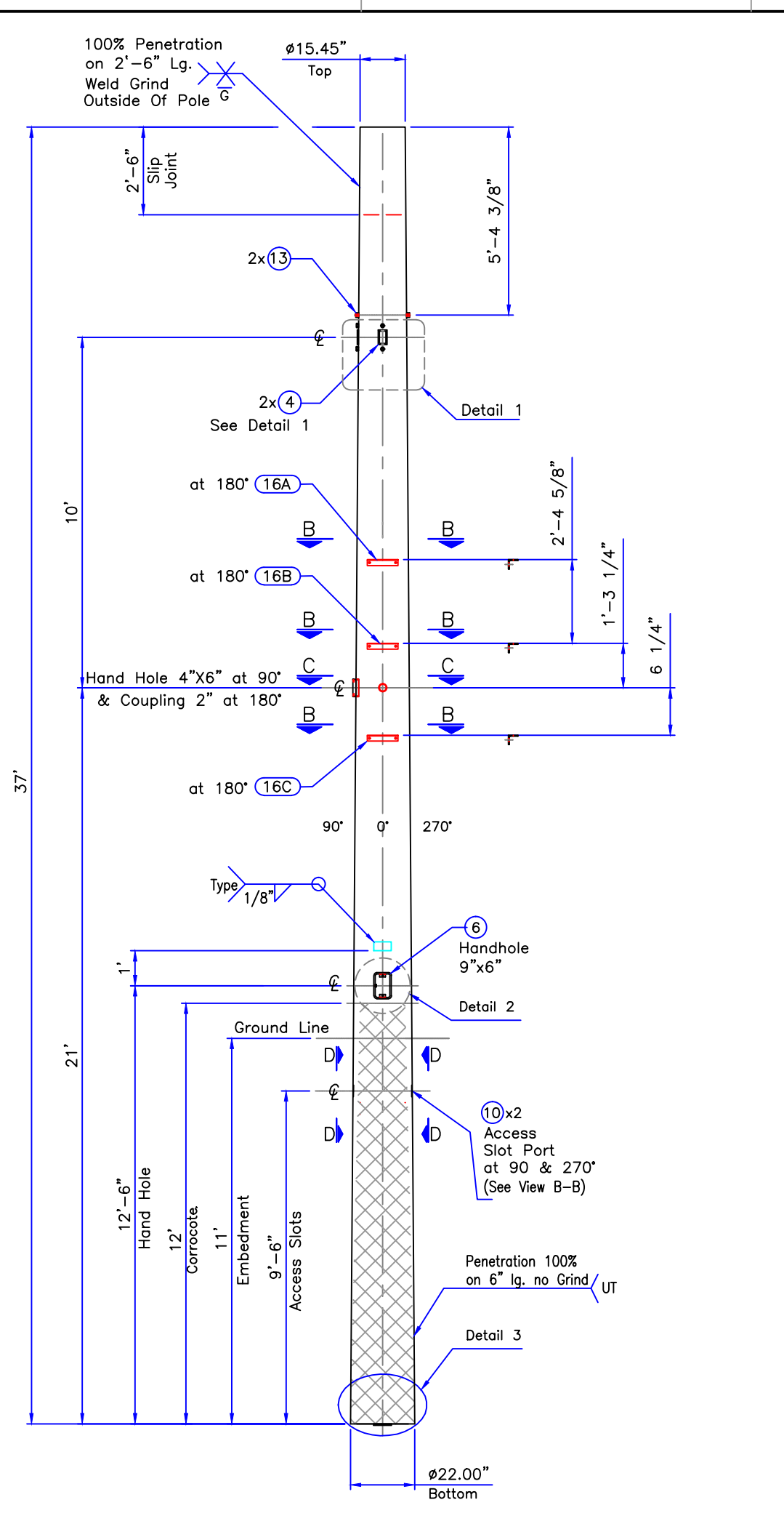

Bottom Section
3/16" Thk. ASTM A-572 GR 65

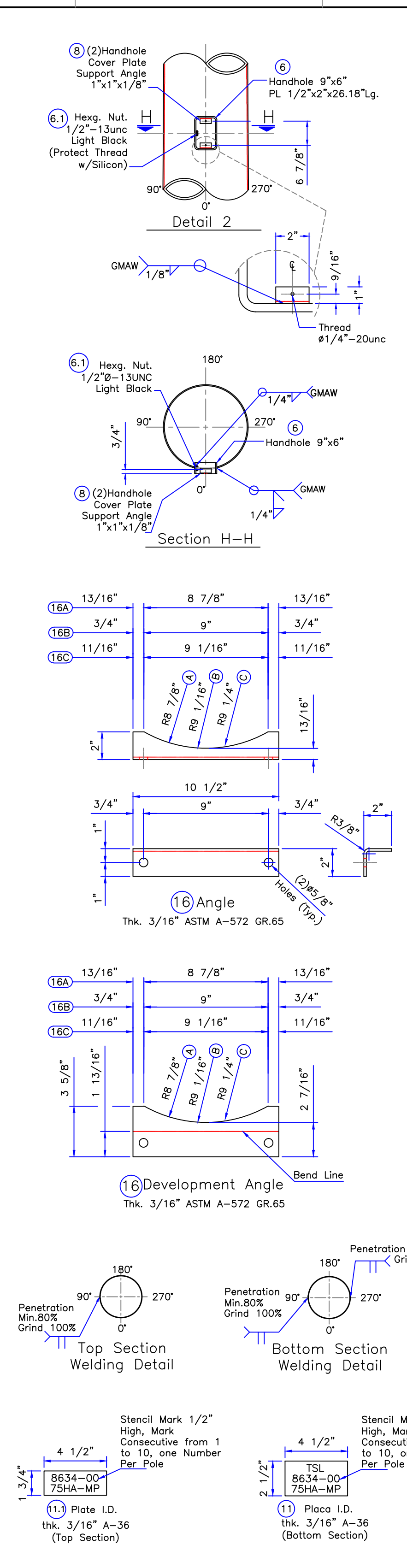
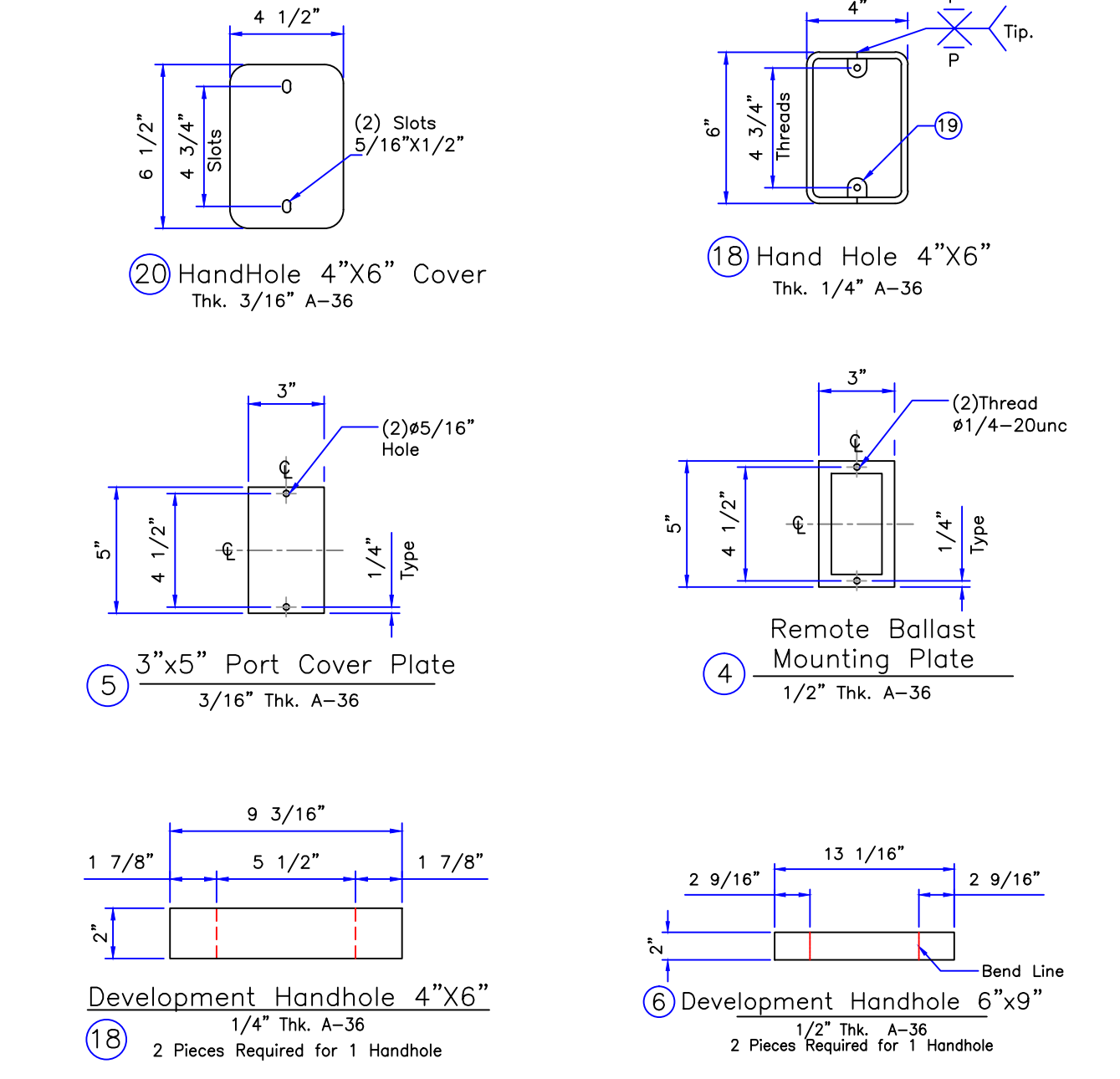
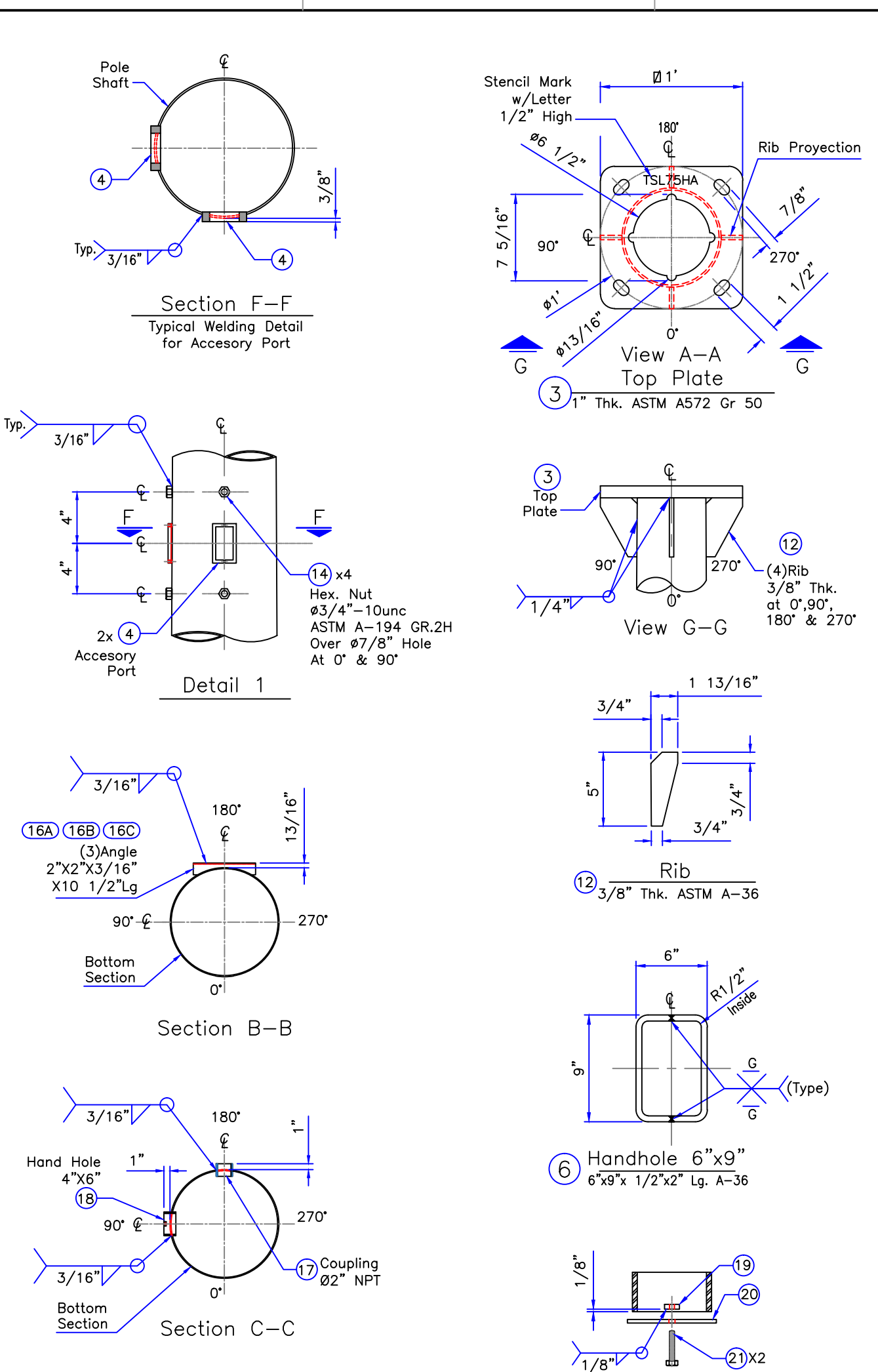
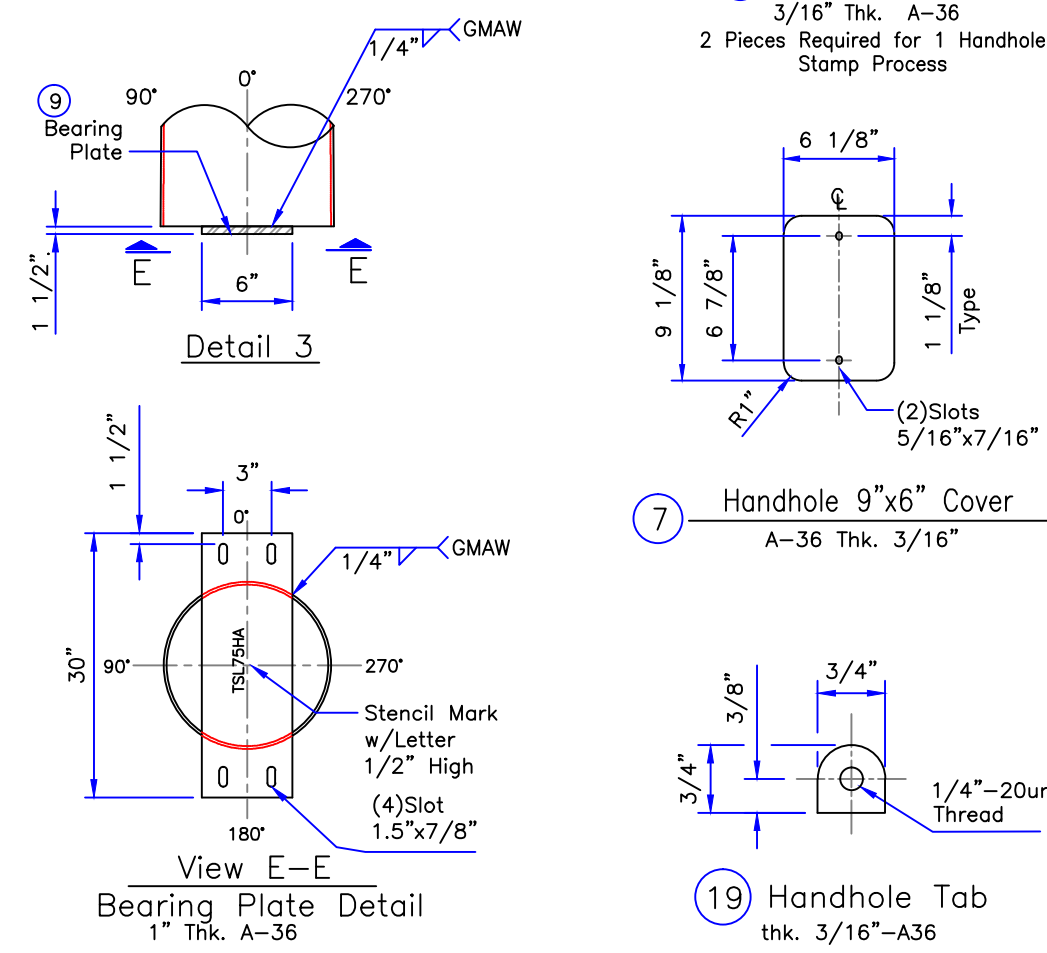
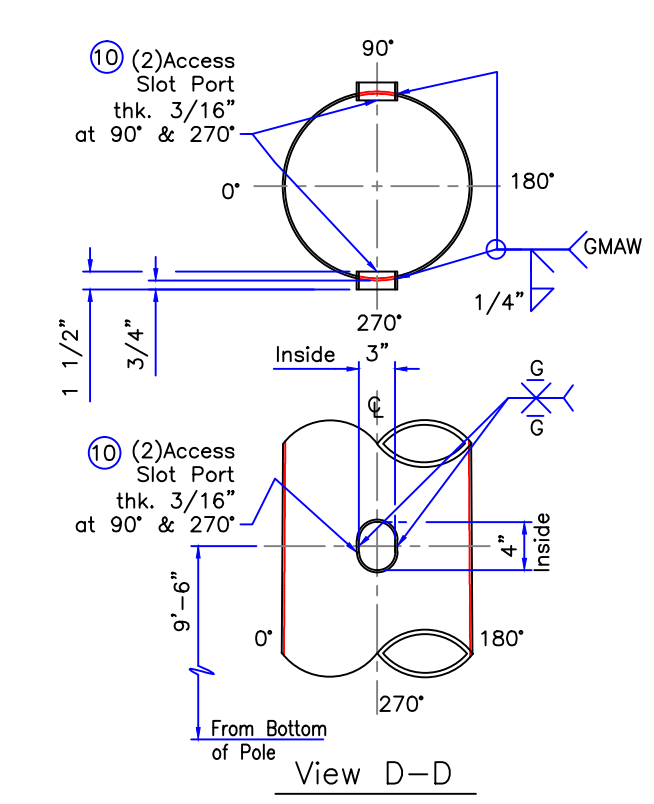

BILL OF MATERIAL						
MARK	QTY.	DESCRIPTION	BOTTOM DIA. INCH	TOP DIA. INCH	PLATE THK. INCH	TOTAL WEIGHT LBS.
1	1	BOTTOM SECTION, PL 1480x1127MM 3/16" THK. A572 GR.65	22.00"	15.45"	3/16"	1400
2	1	TOP SECTION, PL 972x1371MM 3/16" THK. A572 GR.65	16.34"	8.38"	3/16"	1124.30
3	1	TOP PLATE 12"x12"x1" THK.			1"	39.44
4	4	REMOTE BALLAST MOUNTING PLATE 5"x3" 1/2" THK. A-36			1/2"	1.078
5	4	3"x5" PORT COVER PLATE 3/16" THK A-36			3/16"	0.81
6	1	9"x6" HANDHOLE RING, PL 1/2"x2"x26.18"Lg. A-36				7.39
6.1	1	HEXAGONAL NUT #1/2"-13unc Light BLACK				0.31
7	1	9"x6" HANDHOLE COVER PLATE 3/16" THK. A-36			3/16"	2.88
8	2	ANGLE 1"x1/8"x2"Lg.				0.13
9	1	BEARING PLATE PL 6"x30" A-36			1"	16.65
10	2	ACCESS SLOT PORT 4 3/8"x3 3/8"x1 1/2" A-36			3/16"	1.01
11	1	I.D. PLATE 2 1/2" X 4 1/2"			3/16"	0.60
11.1	1	I.D. PLATE 1 3/4" X 4 1/2"			3/16"	0.42
12	4	RIB ASTM A-36			3/8"	0.68
13	4	HEX. NUT #1"-BUNC GR.2H HDG				.92
14	8	HEXAG. NUT #3/4"-10unc ASTM A-572 GR.2H HDG				0.41
16	3	ANGLE ASTM A-572 GR.65			3/16"	2.25
17	1	COUPLING 02" NPT W/INTERNAL THREAD				0.46
18	1	HAND HOLE 4"x6"			1/4"	2.64
19	2	HAND HOLE TAB			3/16"	0.03
20	1	HAND HOLE COVER			3/16"	1.54
21	12	HEXG. HEAD BOLT 1/4"-20UNC X 1 1/2"Lg FULL THREAD GR. MACHINE ELECTROLYTIC GALVANIZED (FOR HAND HOLE COVERS)				0.03
T. WEIGHT LBS 1 PIECE						2623.31

GENERAL TOLERANCES

Builing:

- From 21" to 30" lg= 1/4" Max.
- From 41" to 50" lg= 1/2" Max

Rounding:

- Diameter: +- 1/16"
- Oval: +-1/16" to be Measured on 0° & 180°

Base Plate:

- Outside Dimensions: +- 1/4"
- Length Between Holes: +- 1/8"
- Hole Circle= +- 1/8"
- Diameter Made by CNC: -0 + 1/8"

Accessories:

- Nuts Location: +- 1/8"
- Length Between Nuts: +- 1/8"
- Hand Holes Location: +- 1/8"

Slip Joint:

- Slip Joint: +- 10%

Pole Length:

- Length of Each Section: + 1" - 1/2"

GENERAL NOTES

- DIMENSIONS IN MILLIMETERS AND INCHES UNLESS OTHERWISE SPECIFIED
- HOT DIP GALVANIZED.
- USE THIS FABRICATION DRAWING IN CONJUNCTION WITH DRAWINGS INDICATED AS REFERENCE.
- ALL DIMENSIONS GOVERN OVER DRAWING SCALE, DO NOT SCALE.



TITLE: ASSEMBLY DRAWING & FABRICATION DETAILS	
NAME	DATE
DRAW: RMP	JUL/19
CHECKED: NAVEJAR	JUL/19
APPD: NAVEJAR	JUL/19
QTY:	CATALOGUE: TSL75HA
DRAWING No.:	ITEM: REV.
10774-PTDA5-001	SHEET 1 OF 1

REV.	DESCRIPTION	DATE	BY	REV
REVISIONS				

CUSTOMER:	
NAME	DATE
DRAW: RMP	JUL/19
CHECKED: NAVEJAR	JUL/19
APPD: NAVEJAR	JUL/19



LACH ENGINEERING, LLC.
 539 SILICON DR.
 STE. 100
 SOUTHLAKE, TX, 76092
 (817) 416-9999
www.lachengineering.com

Project Name
TECHLINE SPORTS LIGHTING, LLC.
 #21-3330
PROUT SCHOOL
WAKEFIELD, RHODE ISLAND
MULTI-PURPOSE FIELD
70' LIGHTING POLE FOUNDATION
POLE: P1-P4
LOADING: 45.0 SQ. FT. EPA / 1350.0 LBS

Stamp

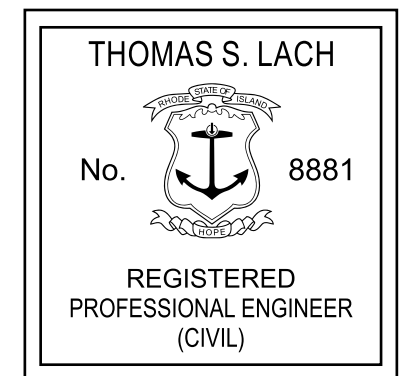

Project Information

Project Number: 8784

Date: 10/04/2021

Sheet Information

Sheet Name: 8784-1

Drawing Scale: NTS

Drawn By: DHG

Sheet

S - 1

OF 1

NOTES: FOUNDATION

1. ALL CONCRETE SHALL HAVE MINIMUM COMPRESSIVE STRENGTH OF 3000 PSI AT 28 DAYS. CONCRETE SHALL HAVE MAXIMUM WATER/CEMENT RATIO OF 0.5. FOUNDATION INSTALLATION SHALL BE IN ACCORDANCE WITH ACI 336, "STANDARD SPECIFICATIONS FOR THE CONSTRUCTION OF DRILLED PIERS", LATEST EDITION.

2. SOIL PARAMETERS ARE BASED UPON GEOTECHNICAL REPORT BY NOBIS GROUP (BORING B-4), DATED SEPTEMBER 28, 2017. REFER TO PAGE 2 OF 14 FOR SOIL PARAMETERS USED IN THE DESIGN. UPON CONSTRUCTION, IF SOIL PARAMETERS DO NOT MEET OR EXCEED THOSE CONTAINED HEREIN, DO NOT SET POLES AND CONTACT DESIGNER IMMEDIATELY.

3. FOUNDATION IS DESIGNED TO SUPPORT THE FOLLOWING LOADS:

AXIAL: 3.80 K
 SHEAR: 4.10 K
 MOMENT: 227.20 K-FT

4. GROUND SLOPE WAS ASSUMED TO NOT EXCEED 7H 1V. IF ACTUAL CONDITIONS VARY FROM THIS ASSUMPTION, PLEASE CONTACT ENGINEER BEFORE CONSTRUCTION.

5. TOP 2' OF FOUNDATION MAY BE FILLED WITH GRAVEL OR CONCRETE.

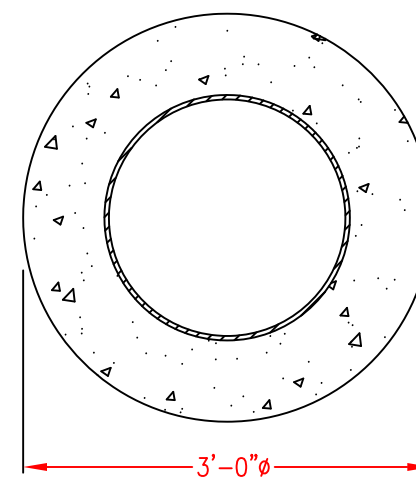
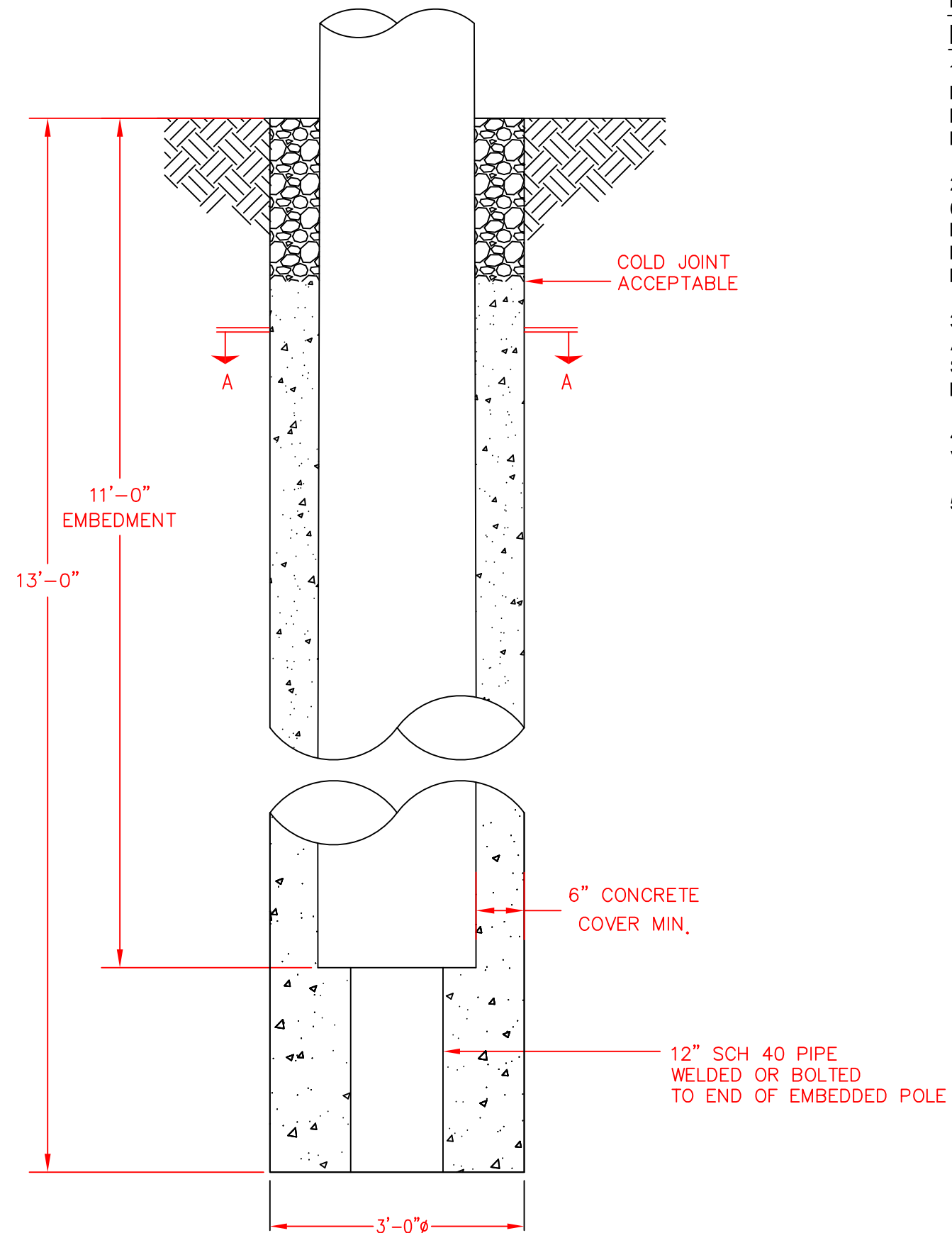

FOUNDATION

SECTION A - A

Dimensional Solutions	Shaft3D 2019	Product Version	21.1.2158.811	Date	10/4/2021 5:06:58 PM
Workspace Name	8784-1				
Designed By	DHG	Checked By:	NHT		
File Path	A:\Design Programs\Foundation Design Suite\S3D\7773-1\8784-1.S3D.dswksp				

REPORT - 8784-1

PROJECT INFORMATION

Client Name: TECHLINE SPORTS LIGHTING, LLC.
Project Name: 70' LIGHTING POLE FOUNDATION (POLES: P1-P4)
Project Number: 8784-1

DESIGN CODE **ACI_318_2014** **INPUT UNITS** **English** **OUTPUT UNITS** **English**

CONCRETE PARAMETERS:

Compressive Strength 3000 psi
Unit Weight 150 pcf
Pier Side Cover 3 in

SOIL PARAMETERS:

Unit Weight 130 pcf
Soil Type Granular
Soil Subtype Silt
Ultimate Cohesion c 0 ksf
Ultimate Adhesion Ad 0 ksf
Passive Pressure Coefficient Ppc 2
Angle of Internal Friction 31

Axial Capacity Parameters

Modulus of Subgrade Reaction Method	Constant	Shaft Type	Drilled
Constant Modulus	740 kcf	Boundary Condition	Trans & Rot at Top
Coefficient A	0	Axial Capacity Method	Use Soil Parameters
Coefficient B	0	Tip Cohesion	0 ksf
Coefficient n	0	Tip Angle of Internal Friction	38
Allowable Increase In Soil Pressure		Tip Soil Unit Weight	125 pcf
Dead	0	Consider End Bearing	True
Live	0	Percent End Bearing	100
Wind	0	Consider Skin Resistance	True
Earthquake	0	Percent Skin Resistance	100
Erec	0	Safety Factor - End Bearing	2
Oper	0	Safety Factor - Skin Resistance	2
Test	0	Safety Factor - Pullout	2
		Safety Factor - Cohesion	2

BUOYANCY CRITERIA:

Consider Buoyancy: No
Water Table Below Grade 50 ft

Soil Profile

No.	Name	Depth	Soil Type	Cohesion	Angle of Int Friction	Unit Weight	Subgrade Modulus	Alpha Factor	Beta Factor	Blow Count
		ft		ksf		pcf	kcf			
1	L1	5	Silt	0	31	130	740	0	0	0
2	L2	3	Sand	0	42	135	610	0	0	0
3	L3	9	Sand	0	38	125	280	0	0	0

Shaft Geometry

Shaft Name	S	
Design Type	Concrete Drilled Shaft	
Shape Factor	1	
Grade Elevation	0	ft
Diameter	3	ft
Top Above Grade	0	ft
Neglected Soil Resistance Zone Length	0	ft
Length Below Neglected Soil Resistance	13	ft
Bell Diameter	0	ft
Bell Length	0	ft
Casing Length	0	ft
Consider Type Dependent Moment of Inertia	True	
Moment of Inertia	3.9760782	ft^4

LOAD ELEMENT GEOMETRY AND APPLIED LOADS

Shaft Element - S - Load Element - S

Geometry	Shape	X Dim	Z Dim	Length	Offset - X	Offset - Z	Min Reinf Ratio
		ft	ft	ft	ft	ft	
	Circle	3	3	13	0	0	0.005
Load Case		Axial Load	Shear-X	Mom-Z	Shear-Z	Mom-X	
		kips	kips	kip-ft	kips	kip-ft	
1 - Dead		3.8	0	0	0	0	
2 - Live		0	0	0	0	0	
3 - Wind		0	4.1	227.2	0	0	
4 - Earthquake		0	0	0	0	0	

ALLOWABLE LOAD COMBINATIONS

Shaft Element - S - Load Element - S

Load Combination	Axial Load	Shear-X	Mom-Z	Shear-Z	Mom-X
	kips	kips	kip-ft	kips	kip-ft
1 - Dead	3.8	0	0	0	0
2 - Dead + Wind	3.8	4.1	227.2	0	0
3 - 0.6 Dead + Wind	2.28	4.1	227.2	0	0

ULTIMATE LOAD COMBINATIONS

Shaft Element - S - Load Element - S

Load Combination	Axial Load	Shear-X	Mom-Z	Shear-Z	Mom-X
	kips	kips	kip-ft	kips	kip-ft
1 - 1.4 Dead	5.32	0	0	0	0
2 - 1.2 Dead + 1.6 Wind	4.56	6.56	363.52	0	0
3 - 1.2 Dead + 0.8 Wind	4.56	3.28	181.76	0	0
4 - 0.9 Dead + 1.6 Wind	3.42	6.56	363.52	0	0

Shaft Element - S

SELF WEIGHTS AND APPLIED EXTERNAL LOAD - Allowable Load Combinations

Load Combination	Load Element Weight kips	Soil Weight kips	Footing Weight kips	App Axial Load kips	Total Axial Load kips	Buoyant Load kips
1 - Dead	13.7837	0	0	3.8	17.5837	
2 - Dead + Wind	13.7837	0	0	3.8	17.5837	
3 - 0.6 Dead + Wind	13.7837	0	0	2.28	16.0637	

Base Shears and Moments - Allowable Load Combinations

Load Combination	Shear-X kips	Mom-Z kip-ft	Shear-Z kips	Mom-X kip-ft
1 - Dead	0	0	0	0
2 - Dead + Wind	4.1	280.5	0	0
3 - 0.6 Dead + Wind	4.1	280.5	0	0

SELF WEIGHTS AND APPLIED EXTERNAL LOAD - Ultimate Load Combinations

Load Combination	Load Element Weight kips	Soil Weight kips	Footing Weight kips	App Axial Load kips	Total Axial Load kips	Buoyant Load kips
1 - 1.4 Dead	19.2972	0	0	5.32	24.6172	
2 - 1.2 Dead + 1.6 Wind	16.5405	0	0	4.56	21.1005	
3 - 1.2 Dead + 0.8 Wind	16.5405	0	0	4.56	21.1005	
4 - 0.9 Dead + 1.6 Wind	16.5405	0	0	3.42	19.9605	

Base Shears and Moments - Ultimate Load Combinations

Load Combination	Shear-X kips	Mom-Z kip-ft	Shear-Z kips	Mom-X kip-ft
1 - 1.4 Dead	0	0	0	0
2 - 1.2 Dead + 1.6 Wind	6.56	448.8	0	0
3 - 1.2 Dead + 0.8 Wind	3.28	224.4	0	0
4 - 0.9 Dead + 1.6 Wind	6.56	448.8	0	0

Axial Capacity - Allowable Load Combinations

Shaft Element - S

Load Combination	App Axial Load kips	All Axial Load kips	Net Uplift Load kips	All Pullout Load kips	Vertical Settlement in	Max Bear Pressure ksf	All Bearing Pressure ksf
1 - Dead	3.8	557.5946	0	-29.2808	0.0167	0	76.6911
2 - Dead + Wind	3.8	557.5946	0	-29.2808	0.0167	0	76.6911
3 - 0.6 Dead + Wind	2.28	557.5946	0	-29.2808	0.013	0	76.6911

Rigid Analysis - Ultimate Load Combinations

Shaft Element - S

Load Combination	Max Mom Location ft	Max Mom Value kip-ft	Crossover Location ft
1 - 1.4 Dead	0	0	13
2 - 1.2 Dead + 1.6 Wind	3.2815	377.8712	13
3 - 1.2 Dead + 0.8 Wind	2.3204	186.8339	10.1966
4 - 0.9 Dead + 1.6 Wind	3.2815	377.8712	13

Finite Element Analysis - Deflections - Allowable Load Combinations

LC #1 : Dead

LC #2 : Dead + Wind

Finite Element Analysis - Deflections - X Dir - Allowable Load Combinations

Shaft Element - S

Node No	Depth ft	LC #1 ft	LC #2 ft	LC #3 ft
1	0.0000	0.0000	0.0063	0.0063
2	0.6250	0.0000	0.0053	0.0053
3	1.2500	0.0000	0.0044	0.0044
4	1.8750	0.0000	0.0036	0.0036
5	2.5000	0.0000	0.0028	0.0028
6	3.1250	0.0000	0.0020	0.0020
7	3.7500	0.0000	0.0013	0.0013
8	4.3750	0.0000	0.0006	0.0006
9	5.0000	0.0000	-0.0001	-0.0001
10	6.0000	0.0000	-0.0011	-0.0011
11	7.0000	0.0000	-0.0020	-0.0020
12	8.0000	0.0000	-0.0029	-0.0029
13	9.7500	0.0000	-0.0044	-0.0044
14	11.3750	0.0000	-0.0057	-0.0057
15	13.0000	0.0000	-0.0070	-0.0070

Finite Element Analysis - Deflections - Z Dir - Allowable Load Combinations

Shaft Element - S

Node No	Depth ft	LC #1 ft	LC #2 ft	LC #3 ft
1	0.0000	0.0000	0.0000	0.0000
2	0.6250	0.0000	0.0000	0.0000
3	1.2500	0.0000	0.0000	0.0000
4	1.8750	0.0000	0.0000	0.0000
5	2.5000	0.0000	0.0000	0.0000
6	3.1250	0.0000	0.0000	0.0000
7	3.7500	0.0000	0.0000	0.0000
8	4.3750	0.0000	0.0000	0.0000
9	5.0000	0.0000	0.0000	0.0000
10	6.0000	0.0000	0.0000	0.0000
11	7.0000	0.0000	0.0000	0.0000
12	8.0000	0.0000	0.0000	0.0000
13	9.7500	0.0000	0.0000	0.0000
14	11.3750	0.0000	0.0000	0.0000
15	13.0000	0.0000	0.0000	0.0000

Finite Element Analysis - Deflections - Ultimate Load Combinations

LC #1 : 1.4 Dead

LC #2 : 1.2 Dead + 1.6 Wind

LC #3 : 1.2 Dead + 0.8 Wind

Finite Element Analysis - Deflections - X Dir - Ultimate Load Combinations

Shaft Element - S

Node No	Depth ft	LC #1 ft	LC #2 ft	LC #3 ft	LC #4 ft
1	0.0000	0.0000	0.0100	0.0050	0.0100
2	0.6250	0.0000	0.0085	0.0043	0.0085
3	1.2500	0.0000	0.0071	0.0035	0.0071
4	1.8750	0.0000	0.0057	0.0029	0.0057
5	2.5000	0.0000	0.0044	0.0022	0.0044
6	3.1250	0.0000	0.0032	0.0016	0.0032
7	3.7500	0.0000	0.0021	0.0010	0.0021
8	4.3750	0.0000	0.0010	0.0005	0.0010
9	5.0000	0.0000	-0.0001	0.0000	-0.0001
10	6.0000	0.0000	-0.0017	-0.0008	-0.0017
11	7.0000	0.0000	-0.0032	-0.0016	-0.0032
12	8.0000	0.0000	-0.0046	-0.0023	-0.0046
13	9.7500	0.0000	-0.0070	-0.0035	-0.0070
14	11.3750	0.0000	-0.0091	-0.0046	-0.0091
15	13.0000	0.0000	-0.0113	-0.0056	-0.0113

Finite Element Analysis - Deflections - Z Dir - Ultimate Load Combinations

Shaft Element - S

Node No	Depth ft	LC #1 ft	LC #2 ft	LC #3 ft	LC #4 ft
1	0.0000	0.0000	0.0000	0.0000	0.0000
2	0.6250	0.0000	0.0000	0.0000	0.0000
3	1.2500	0.0000	0.0000	0.0000	0.0000
4	1.8750	0.0000	0.0000	0.0000	0.0000
5	2.5000	0.0000	0.0000	0.0000	0.0000
6	3.1250	0.0000	0.0000	0.0000	0.0000
7	3.7500	0.0000	0.0000	0.0000	0.0000
8	4.3750	0.0000	0.0000	0.0000	0.0000
9	5.0000	0.0000	0.0000	0.0000	0.0000
10	6.0000	0.0000	0.0000	0.0000	0.0000
11	7.0000	0.0000	0.0000	0.0000	0.0000
12	8.0000	0.0000	0.0000	0.0000	0.0000
13	9.7500	0.0000	0.0000	0.0000	0.0000
14	11.3750	0.0000	0.0000	0.0000	0.0000
15	13.0000	0.0000	0.0000	0.0000	0.0000

Finite Element Analysis - Soil Pressure - Allowable Load Combinations

LC #1 : Dead

LC #2 : Dead + Wind

Finite Element Analysis - Soil Pressure - X Dir - Allowable Load Combinations

Shaft Element - S

Node No	Depth ft	LC #1 ksf	LC #2 ksf	LC #3 ksf
1	0.0000	0.0000	4.6323	4.6323
2	0.6250	0.0000	3.9365	3.9365
3	1.2500	0.0000	3.2751	3.2751
4	1.8750	0.0000	2.6473	2.6473
5	2.5000	0.0000	2.0520	2.0520
6	3.1250	0.0000	1.4874	1.4874
7	3.7500	0.0000	0.9512	0.9512
8	4.3750	0.0000	0.4412	0.4412
9	5.0000	0.0000	-0.0373	-0.0373
10	6.0000	0.0000	-0.6440	-0.6440
11	7.0000	0.0000	-1.2153	-1.2153
12	8.0000	0.0000	-0.8077	-0.8077
13	9.7500	0.0000	-1.2247	-1.2247
14	11.3750	0.0000	-1.5995	-1.5995
15	13.0000	0.0000	-1.9705	-1.9705

Finite Element Analysis - Soil Pressure - Z Dir - Allowable Load Combinations

Shaft Element - S

Node No	Depth ft	LC #1 ksf	LC #2 ksf	LC #3 ksf
1	0.0000	0.0000	0.0000	0.0000
2	0.6250	0.0000	0.0000	0.0000
3	1.2500	0.0000	0.0000	0.0000
4	1.8750	0.0000	0.0000	0.0000
5	2.5000	0.0000	0.0000	0.0000
6	3.1250	0.0000	0.0000	0.0000
7	3.7500	0.0000	0.0000	0.0000
8	4.3750	0.0000	0.0000	0.0000
9	5.0000	0.0000	0.0000	0.0000
10	6.0000	0.0000	0.0000	0.0000
11	7.0000	0.0000	0.0000	0.0000
12	8.0000	0.0000	0.0000	0.0000
13	9.7500	0.0000	0.0000	0.0000
14	11.3750	0.0000	0.0000	0.0000
15	13.0000	0.0000	0.0000	0.0000

Finite Element Analysis - Soil Pressure - Ultimate Load Combinations

LC #1 : 1.4 Dead

LC #2 : 1.2 Dead + 1.6 Wind

LC #3 : 1.2 Dead + 0.8 Wind

Finite Element Analysis - Soil Pressure - X Dir - Ultimate Load Combinations

Shaft Element - S

Node No	Depth ft	LC #1 ksf	LC #2 ksf	LC #3 ksf	LC #4 ksf
1	0.0000	0.0000	7.4117	3.7059	7.4117
2	0.6250	0.0000	6.2984	3.1492	6.2984
3	1.2500	0.0000	5.2401	2.6201	5.2401
4	1.8750	0.0000	4.2357	2.1179	4.2357
5	2.5000	0.0000	3.2832	1.6416	3.2832
6	3.1250	0.0000	2.3798	1.1899	2.3798
7	3.7500	0.0000	1.5219	0.7610	1.5219
8	4.3750	0.0000	0.7059	0.3530	0.7059
9	5.0000	0.0000	-0.0597	-0.0299	-0.0597
10	6.0000	0.0000	-1.0303	-0.5152	-1.0303
11	7.0000	0.0000	-1.9445	-0.9722	-1.9445
12	8.0000	0.0000	-1.2923	-0.6461	-1.2923
13	9.7500	0.0000	-1.9595	-0.9798	-1.9595
14	11.3750	0.0000	-2.5593	-1.2796	-2.5593
15	13.0000	0.0000	-3.1529	-1.5764	-3.1529

Finite Element Analysis - Soil Pressure - Z Dir - Ultimate Load Combinations

Shaft Element - S

Node No	Depth ft	LC #1 ksf	LC #2 ksf	LC #3 ksf	LC #4 ksf
1	0.0000	0.0000	0.0000	0.0000	0.0000
2	0.6250	0.0000	0.0000	0.0000	0.0000
3	1.2500	0.0000	0.0000	0.0000	0.0000
4	1.8750	0.0000	0.0000	0.0000	0.0000
5	2.5000	0.0000	0.0000	0.0000	0.0000
6	3.1250	0.0000	0.0000	0.0000	0.0000
7	3.7500	0.0000	0.0000	0.0000	0.0000
8	4.3750	0.0000	0.0000	0.0000	0.0000
9	5.0000	0.0000	0.0000	0.0000	0.0000
10	6.0000	0.0000	0.0000	0.0000	0.0000
11	7.0000	0.0000	0.0000	0.0000	0.0000
12	8.0000	0.0000	0.0000	0.0000	0.0000
13	9.7500	0.0000	0.0000	0.0000	0.0000
14	11.3750	0.0000	0.0000	0.0000	0.0000
15	13.0000	0.0000	0.0000	0.0000	0.0000

Finite Element Analysis - Shear Forces - Allowable Load Combinations

LC #1 : Dead

LC #2 : Dead + Wind

Finite Element Analysis - Shear Forces - X Dir - Allowable Load Combinations

Shaft Element - S

Node No	Depth ft	LC #1 kips	LC #2 kips	LC #3 kips
1	0.0000	0.0000	-4.1000	-4.1000
2	0.6250	0.0000	0.2428	0.2428
3	1.2500	0.0000	7.6237	7.6237
4	1.8750	0.0000	13.7645	13.7645
5	2.5000	0.0000	18.7282	18.7282
6	3.1250	0.0000	22.5758	22.5758
7	3.7500	0.0000	25.3646	25.3646
8	4.3750	0.0000	27.1481	27.1481
9	5.0000	0.0000	27.9511	27.9511
10	6.0000	0.0000	27.8577	27.8577
11	7.0000	0.0000	25.9258	25.9258
12	8.0000	0.0000	22.6086	22.6086
13	9.7500	0.0000	18.8010	18.8010
14	11.3750	0.0000	12.6010	12.6010
15	13.0000	0.0000	4.8032	4.8032

Finite Element Analysis - Shear Forces - Z Dir - Allowable Load Combinations

Shaft Element - S

Node No	Depth ft	LC #1 kips	LC #2 kips	LC #3 kips
1	0.0000	0.0000	0.0000	0.0000
2	0.6250	0.0000	0.0000	0.0000
3	1.2500	0.0000	0.0000	0.0000
4	1.8750	0.0000	0.0000	0.0000
5	2.5000	0.0000	0.0000	0.0000
6	3.1250	0.0000	0.0000	0.0000
7	3.7500	0.0000	0.0000	0.0000
8	4.3750	0.0000	0.0000	0.0000
9	5.0000	0.0000	0.0000	0.0000
10	6.0000	0.0000	0.0000	0.0000
11	7.0000	0.0000	0.0000	0.0000
12	8.0000	0.0000	0.0000	0.0000
13	9.7500	0.0000	0.0000	0.0000
14	11.3750	0.0000	0.0000	0.0000
15	13.0000	0.0000	0.0000	0.0000

Finite Element Analysis - Shear Forces - Ultimate Load Combinations

LC #1 : 1.4 Dead

LC #2 : 1.2 Dead + 1.6 Wind

LC #3 : 1.2 Dead + 0.8 Wind

Finite Element Analysis - Shear Forces - X Dir - Ultimate Load Combinations

Shaft Element - S

Node No	Depth ft	LC #1 kips	LC #2 kips	LC #3 kips	LC #4 kips
1	0.0000	0.0000	-6.5600	-3.2800	-6.5600
2	0.6250	0.0000	0.3885	0.1942	0.3885
3	1.2500	0.0000	12.1979	6.0990	12.1979
4	1.8750	0.0000	22.0232	11.0116	22.0232
5	2.5000	0.0000	29.9652	14.9826	29.9652
6	3.1250	0.0000	36.1213	18.0606	36.1213
7	3.7500	0.0000	40.5834	20.2917	40.5834
8	4.3750	0.0000	43.4370	21.7185	43.4370
9	5.0000	0.0000	44.7218	22.3609	44.7218
10	6.0000	0.0000	44.5723	22.2862	44.5723
11	7.0000	0.0000	41.4813	20.7406	41.4813
12	8.0000	0.0000	36.1738	18.0869	36.1738
13	9.7500	0.0000	30.0816	15.0408	30.0816
14	11.3750	0.0000	20.1616	10.0808	20.1616
15	13.0000	0.0000	7.6851	3.8425	7.6851

Finite Element Analysis - Shear Forces - Z Dir - Ultimate Load Combinations

Shaft Element - S

Node No	Depth ft	LC #1 kips	LC #2 kips	LC #3 kips	LC #4 kips
1	0.0000	0.0000	0.0000	0.0000	0.0000
2	0.6250	0.0000	0.0000	0.0000	0.0000
3	1.2500	0.0000	0.0000	0.0000	0.0000
4	1.8750	0.0000	0.0000	0.0000	0.0000
5	2.5000	0.0000	0.0000	0.0000	0.0000
6	3.1250	0.0000	0.0000	0.0000	0.0000
7	3.7500	0.0000	0.0000	0.0000	0.0000
8	4.3750	0.0000	0.0000	0.0000	0.0000
9	5.0000	0.0000	0.0000	0.0000	0.0000
10	6.0000	0.0000	0.0000	0.0000	0.0000
11	7.0000	0.0000	0.0000	0.0000	0.0000
12	8.0000	0.0000	0.0000	0.0000	0.0000
13	9.7500	0.0000	0.0000	0.0000	0.0000
14	11.3750	0.0000	0.0000	0.0000	0.0000
15	13.0000	0.0000	0.0000	0.0000	0.0000

Finite Element Analysis - Bending Moments - Allowable Load Combinations

LC #1 : Dead

LC #2 : Dead + Wind

Finite Element Analysis - Bending Moments - X Dir - Allowable Load Combinations

Shaft Element - S

Node No	Depth ft	LC #1 kip-ft	LC #2 kip-ft	LC #3 kip-ft
1	0.0000	0.0000	-227.2000	-227.2000
2	0.6250	0.0000	-227.0483	-227.0483
3	1.2500	0.0000	-222.2834	-222.2834
4	1.8750	0.0000	-213.6806	-213.6806
5	2.5000	0.0000	-201.9755	-201.9755
6	3.1250	0.0000	-187.8656	-187.8656
7	3.7500	0.0000	-172.0127	-172.0127
8	4.3750	0.0000	-155.0452	-155.0452
9	5.0000	0.0000	-137.5757	-137.5757
10	6.0000	0.0000	-109.7180	-109.7180
11	7.0000	0.0000	-83.7922	-83.7922
12	8.0000	0.0000	-61.1836	-61.1836
13	9.7500	0.0000	-28.2818	-28.2818
14	11.3750	0.0000	-7.8052	-7.8052
15	13.0000	0.0000	0.0000	0.0000

Finite Element Analysis - Bending Moments - Z Dir - Allowable Load Combinations

Shaft Element - S

Node No	Depth ft	LC #1 kip-ft	LC #2 kip-ft	LC #3 kip-ft
1	0.0000	0.0000	0.0000	0.0000
2	0.6250	0.0000	0.0000	0.0000
3	1.2500	0.0000	0.0000	0.0000
4	1.8750	0.0000	0.0000	0.0000
5	2.5000	0.0000	0.0000	0.0000
6	3.1250	0.0000	0.0000	0.0000
7	3.7500	0.0000	0.0000	0.0000
8	4.3750	0.0000	0.0000	0.0000
9	5.0000	0.0000	0.0000	0.0000
10	6.0000	0.0000	0.0000	0.0000
11	7.0000	0.0000	0.0000	0.0000
12	8.0000	0.0000	0.0000	0.0000
13	9.7500	0.0000	0.0000	0.0000
14	11.3750	0.0000	0.0000	0.0000
15	13.0000	0.0000	0.0000	0.0000

Finite Element Analysis - Bending Moments - Ultimate Load Combinations

LC #1 : 1.4 Dead

LC #2 : 1.2 Dead + 1.6 Wind

LC #3 : 1.2 Dead + 0.8 Wind

Finite Element Analysis - Bending Moments - X Dir - Ultimate Load Combinations

Shaft Element - S

Node No	Depth ft	LC #1 kip-ft	LC #2 kip-ft	LC #3 kip-ft	LC #4 kip-ft
1	0.0000	0.0000	-363.5200	-181.7600	-363.5200
2	0.6250	0.0000	-363.2772	-181.6386	-363.2772
3	1.2500	0.0000	-355.6535	-177.8267	-355.6535
4	1.8750	0.0000	-341.8890	-170.9445	-341.8890
5	2.5000	0.0000	-323.1608	-161.5804	-323.1608
6	3.1250	0.0000	-300.5850	-150.2925	-300.5850
7	3.7500	0.0000	-275.2204	-137.6102	-275.2204
8	4.3750	0.0000	-248.0723	-124.0361	-248.0723
9	5.0000	0.0000	-220.1211	-110.0606	-220.1211
10	6.0000	0.0000	-175.5488	-87.7744	-175.5488
11	7.0000	0.0000	-134.0675	-67.0338	-134.0675
12	8.0000	0.0000	-97.8937	-48.9469	-97.8937
13	9.7500	0.0000	-45.2508	-22.6254	-45.2508
14	11.3750	0.0000	-12.4883	-6.2441	-12.4883
15	13.0000	0.0000	0.0000	0.0000	0.0000

Finite Element Analysis - Bending Moments - Z Dir - Ultimate Load Combinations

Shaft Element - S

Node No	Depth ft	LC #1 kip-ft	LC #2 kip-ft	LC #3 kip-ft	LC #4 kip-ft
1	0.0000	0.0000	0.0000	0.0000	0.0000
2	0.6250	0.0000	0.0000	0.0000	0.0000
3	1.2500	0.0000	0.0000	0.0000	0.0000
4	1.8750	0.0000	0.0000	0.0000	0.0000
5	2.5000	0.0000	0.0000	0.0000	0.0000
6	3.1250	0.0000	0.0000	0.0000	0.0000
7	3.7500	0.0000	0.0000	0.0000	0.0000
8	4.3750	0.0000	0.0000	0.0000	0.0000
9	5.0000	0.0000	0.0000	0.0000	0.0000
10	6.0000	0.0000	0.0000	0.0000	0.0000
11	7.0000	0.0000	0.0000	0.0000	0.0000
12	8.0000	0.0000	0.0000	0.0000	0.0000
13	9.7500	0.0000	0.0000	0.0000	0.0000
14	11.3750	0.0000	0.0000	0.0000	0.0000
15	13.0000	0.0000	0.0000	0.0000	0.0000

PIER DESIGN - Ultimate Load Combinations

Modulus of Elasticity of Concrete - Section 19.2

Concrete Stress Distribution - Section 22.2.2

Design Axial Strength - Section 22.4

Shaft Element - S

Load Element - S

Geometry

Shape	Circle	
X Dim	3	ft
Z Dim	3	ft
Height	13	ft
Offset - X	0	ft
Offset - Z	0	ft

Pier Concrete Capacity

Load Combination	Applied Axial Load	Allowable Axial Load	Applied Moment Resultant	Allowable Moment Resultant	Capacity Ratio
	kips	kips	kip-ft	kip-ft	
1 - 1.4 Dead	5.32	1017.4254	0	0.1017	191.2454
2 - 1.2 Dead + 1.6 Wind	4.56	5.4913	377.8712	455.0413	1.2042
3 - 1.2 Dead + 0.8 Wind	4.56	11.3766	186.8339	466.1247	2.4949
4 - 0.9 Dead + 1.6 Wind	3.42	4.0963	377.8712	452.5914	1.1977

Qty - 4

TOP VIEW

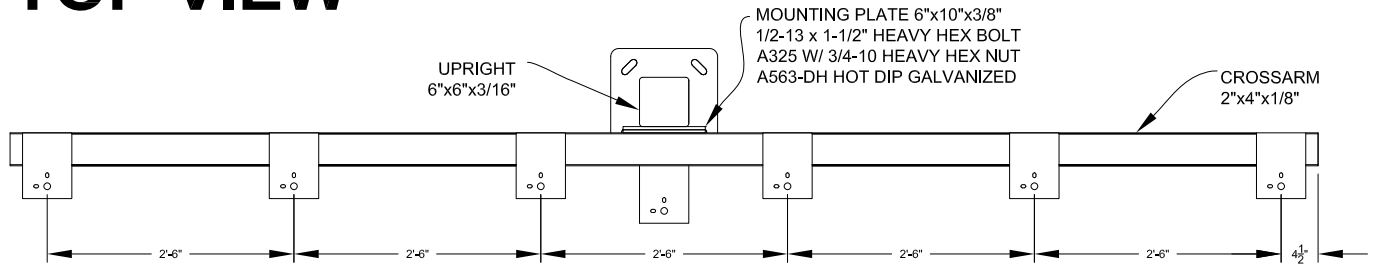

FRONT VIEW

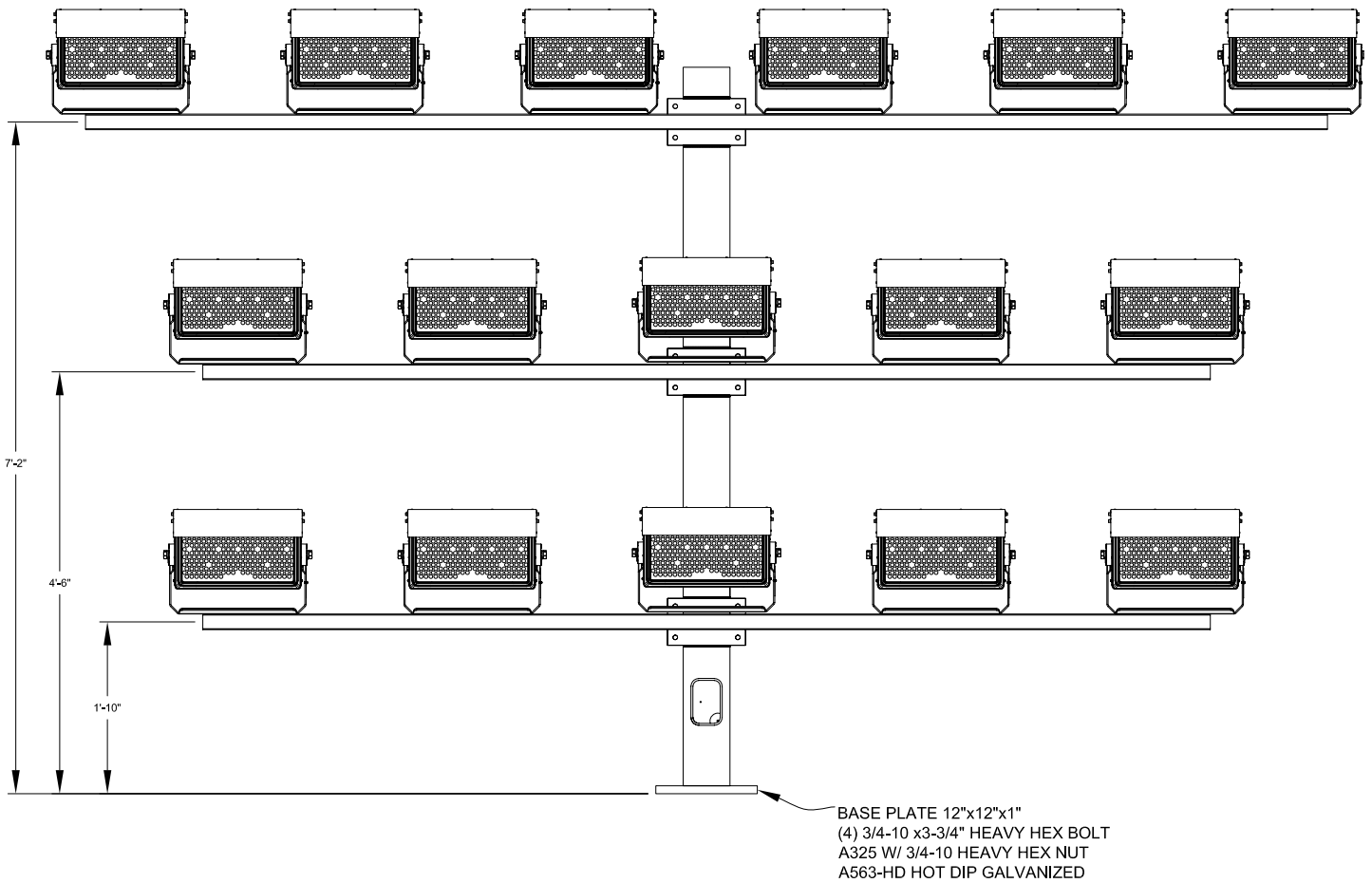

** NOT TO SCALE

** Hot-Dip galvanized after fabrication to ASTM A123 specifications

** Assembly Weight: 1,038 lbs
Assembly EPA: 40.19 sq. ft.
(Including Fixtures)

15303 STORM DR.
AUSTIN, TX 78734
PHONE: (512)977-8880
TOLL FREE: (800)500-3161
FAX: (512)977-8882

DATE: 1/1/20	REV.:	CHECKED BY:
DRAWING NUMBER: TTA 16 (CLIR)	DRAWN BY: WW	

16 FIXTURE CROSSARM ASSEMBLY

ELITE SERIES
CLIR 630w

**Qty - 64 (All fixtures include
our 20" visors, see last page)**

TECHNICAL DATA
FIXTURE



ELITE SERIES
CLIR 630w

TECHNICAL DATA
SYSTEM SPECIFICATIONS

- SYSTEM WATTS: **630w**
- LUMEN OUTPUT: **85,000**
- kW Load: **646 watts**
- EPA: **1.5**
- WEIGHT: **41lbs**
- CLIR Module: **OM, CM, ECM**
- BEAM ANGLE: **N, M, W, EW**
- POWER FACTOR: **0.95**
- CCT: **5700K**
- CRI: **>70Ra**
- INPUT VOLTAGE: **208-480v**
- INPUT PROTECTION: **10KV Current Surge**
- DRIVER: **Integral, Remote**
- IP RATING: **IP66, IP68**
- OPERATING TEMP RANGE: **-40°C to +55°C**
- HOUSING MATERIAL: **Aluminum Powder Coated**



ELITE SERIES
CLIR 630w

TECHNICAL DATA
TECHNOLOGY CHANGES PERFORMANCE

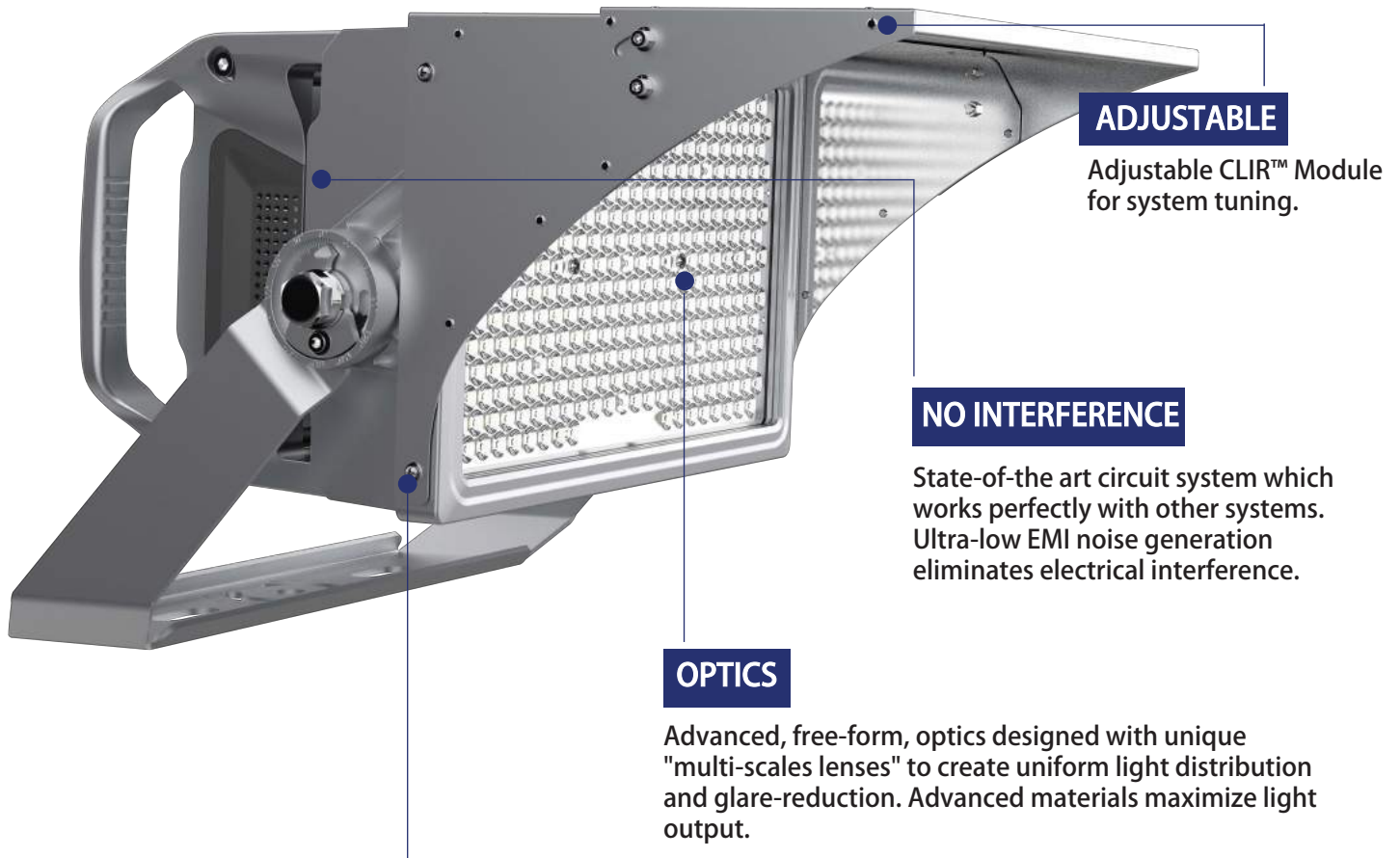

ADJUSTABLE

Adjustable CLIR™ Module for system tuning.

NO INTERFERENCE

State-of-the art circuit system which works perfectly with other systems. Ultra-low EMI noise generation eliminates electrical interference.

OPTICS

Advanced, free-form, optics designed with unique "multi-scales lenses" to create uniform light distribution and glare-reduction. Advanced materials maximize light output.

SOLID STATE DESIGN

Unique "SSD" design, simple, and advanced. Ensures durability of LED chip. All parts are individual, rugged and strong.

ELITE SERIES

CLIR 630w - Standard Visor

TECHNICAL DATA

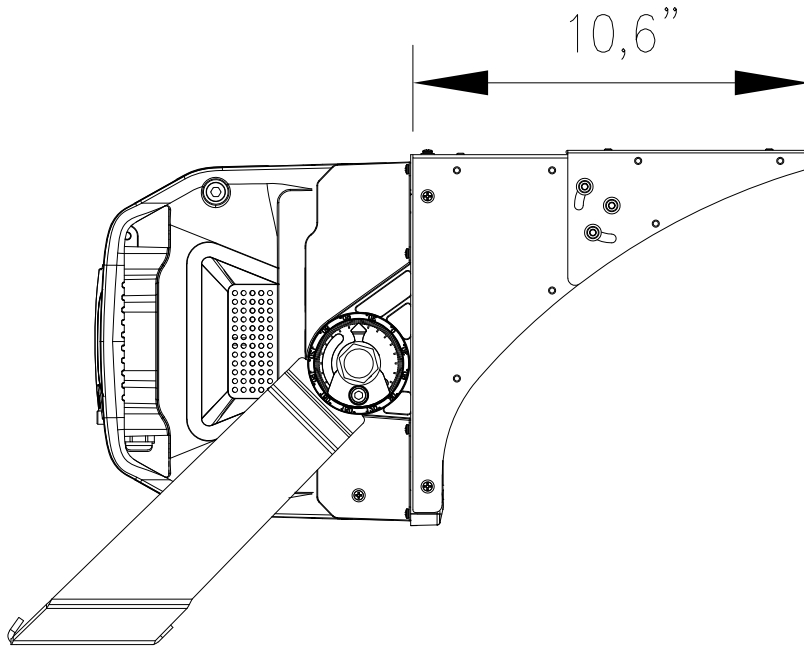

Fixture Aimed 25° Below Horizontal

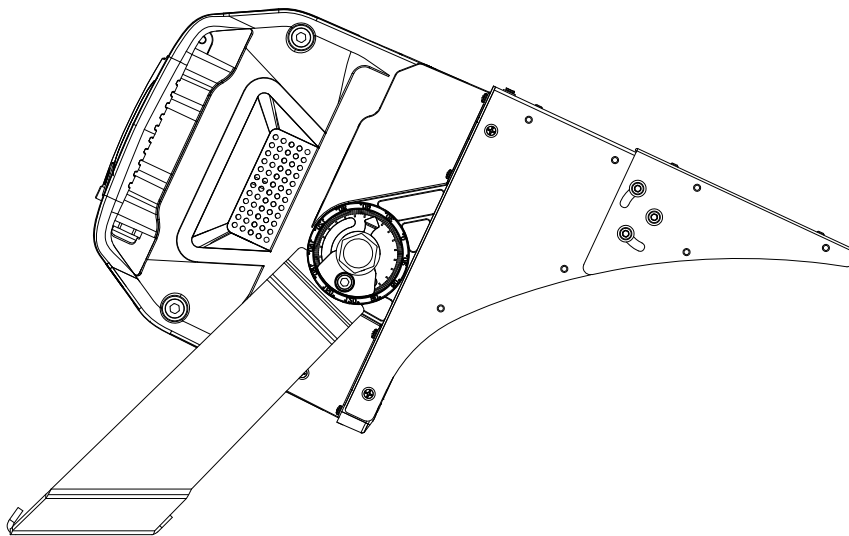

ELITE SERIES

CLIR 630w - Extended Visor

***SPECIAL ORDER OPTION**

TECHNICAL DATA

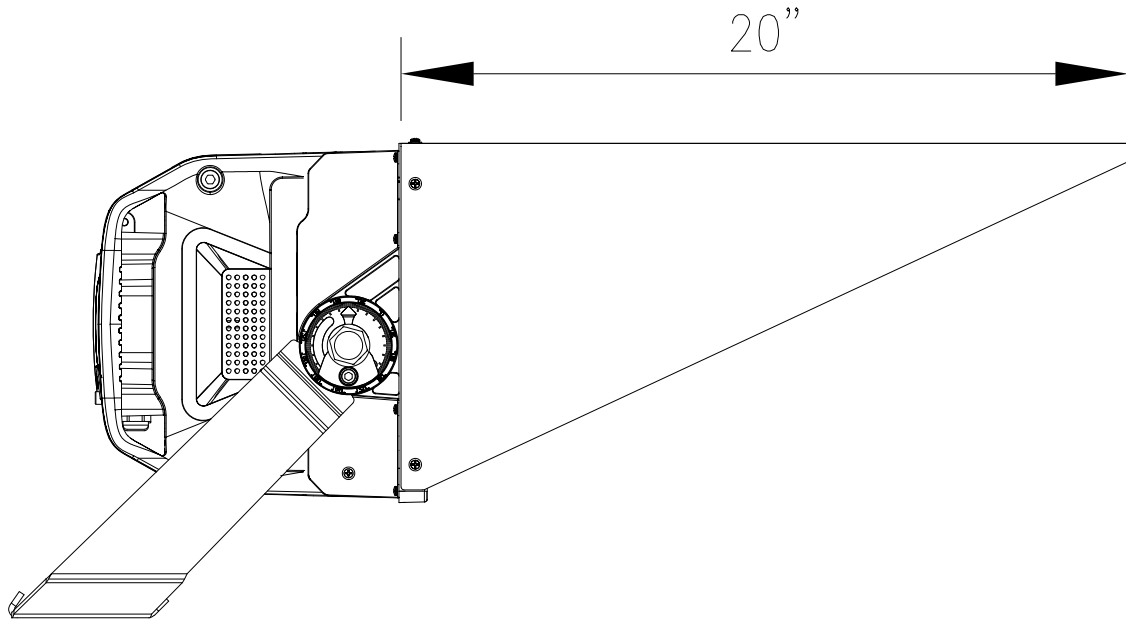

Fixture Aimed 25° Below Horizontal

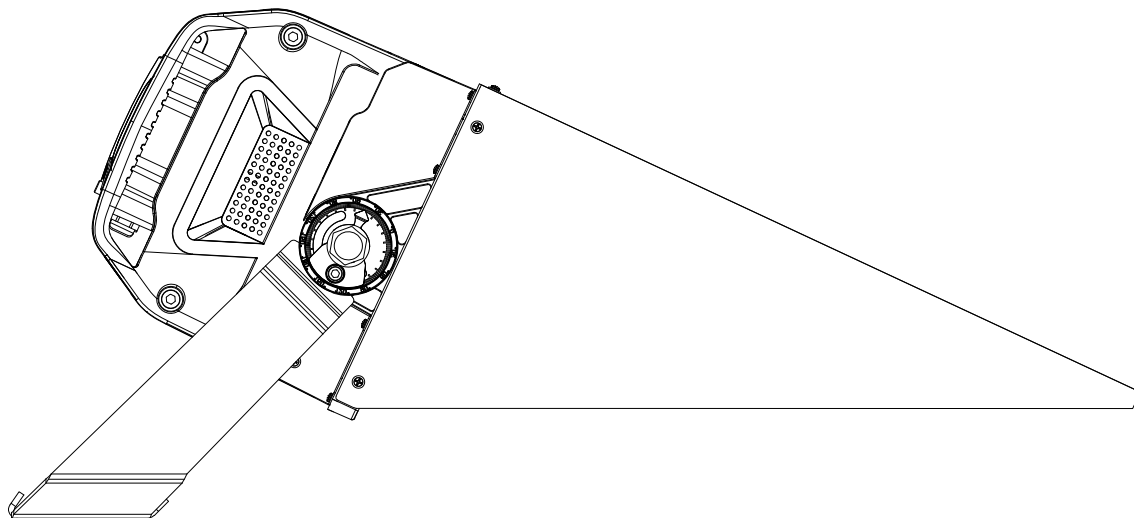

CLIR 630w

Qty - 4 (1 ea. Pole)

TECHNICAL DATA
SIMPLE SYSTEM DRAWING

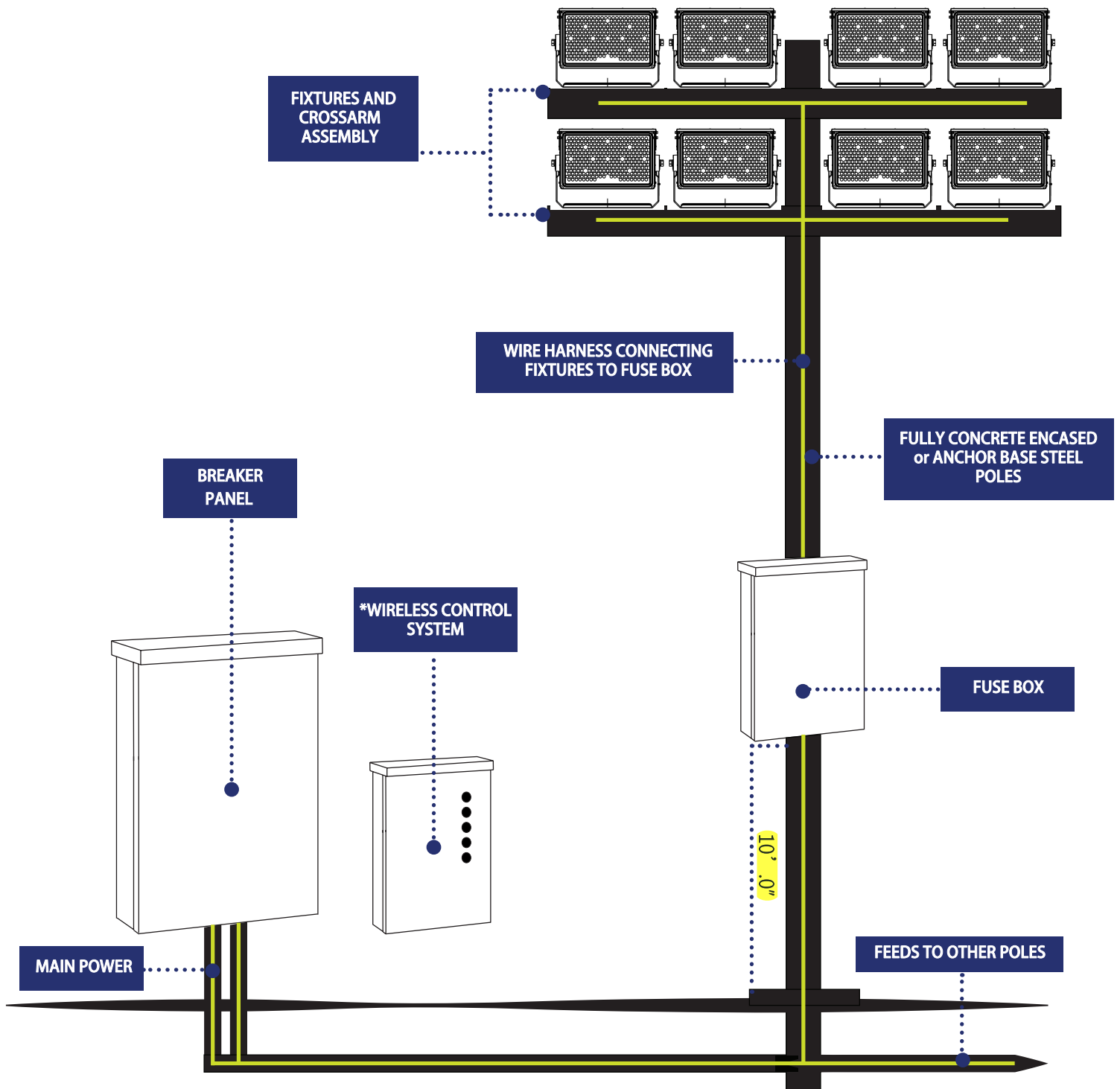

CLIR 630w

TECHNICAL DATA
FUSE BOX

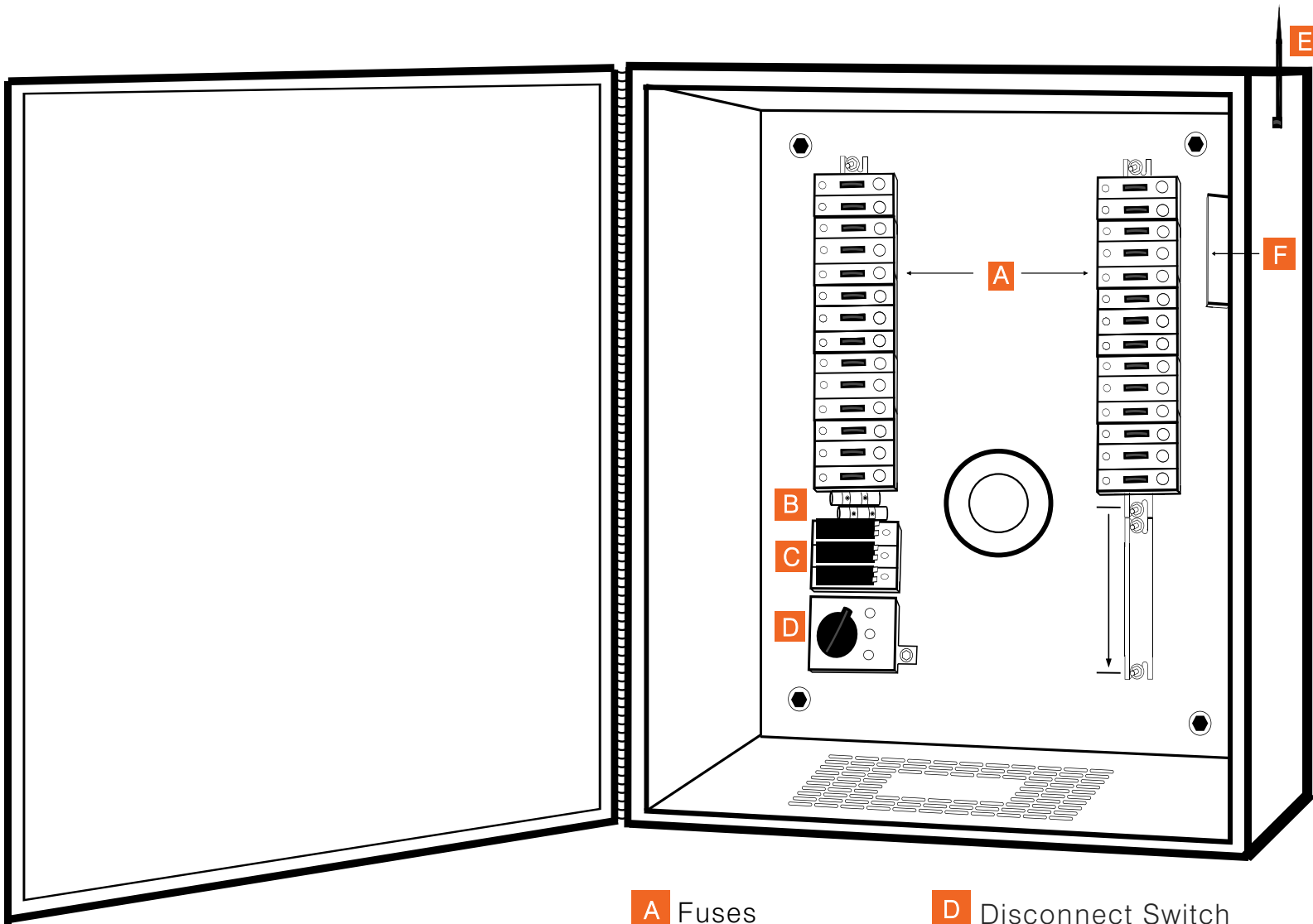

Drawings do not designate fuse size, wiring, NEMA box type, distribution block information, disconnect switch size, ampacity, and surge arrester specification

Drawing depicts a typical example of a Fuse Box (control enclosure)

A customized Fuse Box will be designed for any specific required application

- A** Fuses
- B** Ground Block
- C** Distribution Block
- D** Disconnect Switch
- E** Wireless Antenna
- F** Wireless Relay (Dimming – On/Off)

G *Alternate Control Option
(Simple ON/OFF No Dimming)

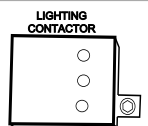

Allows Digital Contactor (AirMesh Hub by Synapse) the ability to remotely turn lights ON/OFF. This option DOES NOT allow dimming capability.

CLIR 630w

TECHNICAL DATA WIRELESS CONTROLLER (CONTROLLER ACCESSORIES)

Product Overview

The **Wireless Controller** is a SimplySNAP component that can be installed anywhere you need wireless push-button lighting control, such as municipal ballparks, hockey arenas, basketball facilities, and other multi-use complexes.

The heart of the Wireless Controller is the SS450 site controller, contained in the NEMA 4X enclosure with 5 buttons that allow for controlled manual access to site lighting.

The Wireless Controller makes it easy for electricians to quickly install the SimplySNAP site controller and enables quick and simple access to a switch station that can be programmed to meet the needs of the end-user.

Features

- Allows for controlled manual access to a SimplySNAP lighting system
- Weather protected — perfect for both indoor and outdoor applications
- Optional, pre-configured 5-button switch to allow for control of all lighting within the facility
- External Ethernet port for connecting to IT network



Product #	Description
CBSSW-450-001 Cellular & Wi-Fi	SS450-based Model w/ 5-button switch

Dimensions	15.5" x 13.5" x 7.7" (393 x 342 x 195 mm)
Input Power	90-120VAC; 8W max, 6kV surge protection
Operating Environment	-20°C to +55°C, IP65
Radio	SNAP 2.4GHz 802.15.4 Wi-Fi 2.4Ghz 802.11 b/g/n
Certifications	FCC/IC; Tested to CAN/CSA C22.2 No. 60950-1/A2:2014 and UL 60950-1/R:2014-10

To learn more, call or visit:
synapsewireless.com
(877) 982-7888



©2017 Synapse Wireless, Inc. all rights reserved. Synapse products are patented or patent pending. Specifications subject to change without notice. DOC-1000085-A-1

CLIR 630w

TECHNICAL DATA
WIRELESS CONTROLS

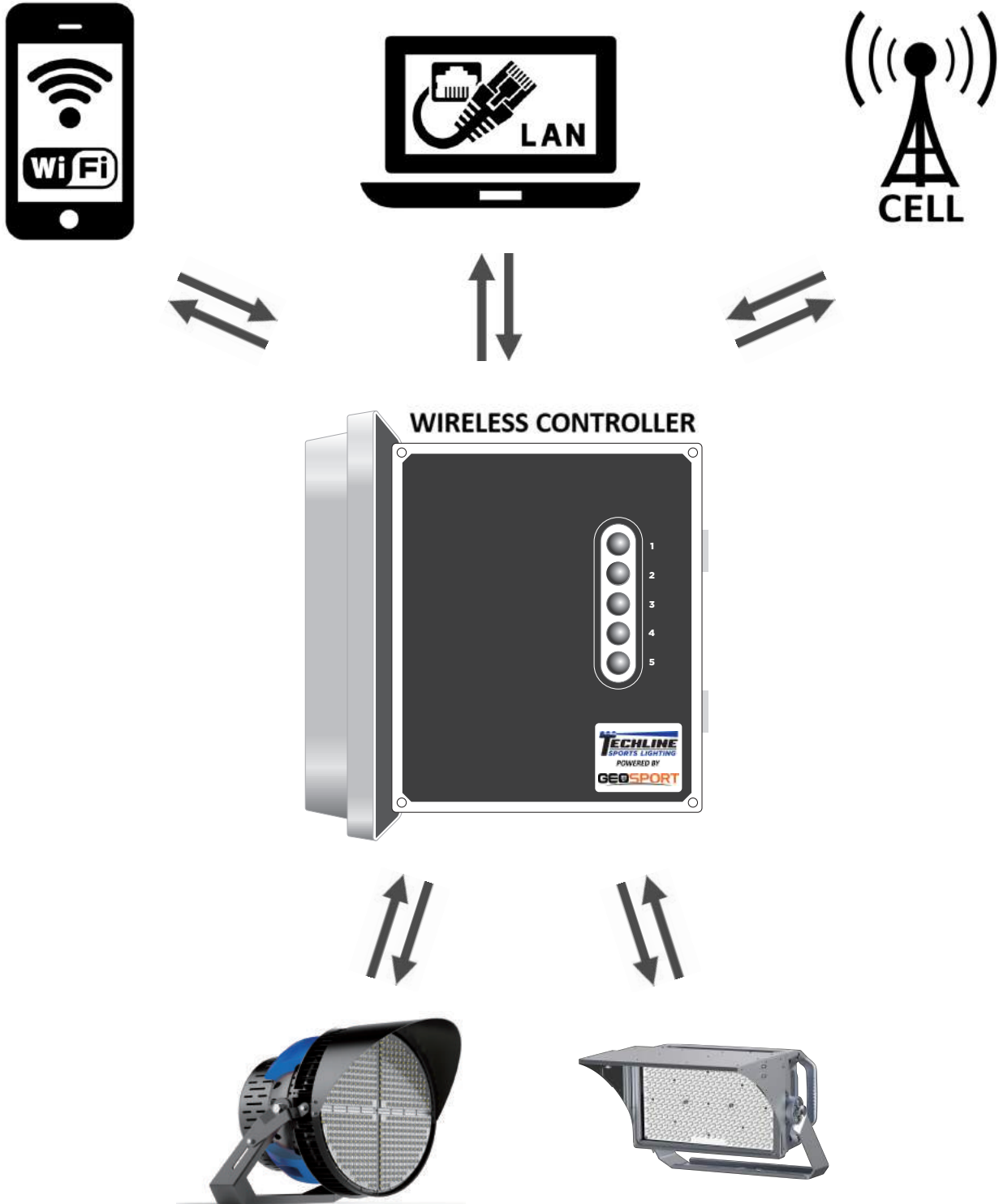

WARRANTY

25-YEAR MANUFACTURER WARRANTY

TERMS & CONDITIONS

(1 of 2)

Service under this Contract is provided by Geo-Surfaces Manufacturing, LLC (GML). Services completed under this Contract shall consist of furnishing labor and parts necessary to restore the operation of the Warranted Product(s) to original design conditions provided such service is necessitated by failure of the Warranted Product(s) during normal usage. This Contract covers Product(s) consisting of GeoSport™ Lighting LED System.

“We”, “us” and “our” mean GML. “You” and “your” mean the Purchaser of the Warranted Product(s). No one has the authority to change this Contract without the prior written approval of GML. GML shall not assume responsibility for their agents or assignees other than as described below. If there is a conflict between the terms of this Contract and information communicated either orally or in writing by one or more of our employees or agents, this Contract shall control.

1. Special Warranty: Manufacturer’s standard form in which manufacturer agrees to repair or replace components of luminaires, lamps, and luminaire alignment products and to correct misalignment that occurs subsequent to successful acceptance tests. Manufacturer may exclude lightning damage, hail damage, vandalism, abuse, and unauthorized repairs and alterations from special warranty coverage.

2. Warranty Period: Twenty-five (25) year(s) from date of Substantial Completion.

3. Hours of Usage: Designs shall be based on the following hours of usage:

Field Type	Annual Usage Hours	25-Year Usage Hours
All Field Types	300	7,500

- a. Manufacturer shall provide a means of tracking actual hours of usage for the field lighting system that is readily accessible to the owner.
- b. Cumulative hours shall be tracked to show the total hours used by the facility.

4. Service Availability: Maintenance service specialists shall be available 8:00am to 5:00pm Central Standard Time, and services shall be performed during these same hours in your local time zone, Monday through Friday (with the exception of national holidays). Hours of operation are subject to change without notice. GML will exercise all reasonable efforts to perform service under this Contract but will not be responsible for delays or failure in performing such services caused by adverse weather conditions, acts of any government, failure of transportation, accidents, riots, war, labor actions or strikes or other causes beyond its control.

5. Repair Determination: GML will utilize the monitoring system and any information provided by the customer to determine when the usage of the field is materially impacted. From this information, GML will determine repair and/or replacement of Warranted Product(s) and parts. Repair will be with product(s) of similar kind and quality.

Your Requirements Under this Contract: You must meet all electrical and installation requirements as specified by the Manufacturer. In addition, you assure: full cooperation with GML technicians and authorized servicers during diagnosis and repair of the Warranted Product(s); reasonable accessibility of the Warranted Product(s); a non- threatening and safe environment for service. You agree to check and replace fuses as needed. GML provides spare fuses in each A-pole enclosure. GML will replace spare fuses used. You agree to keep your control system online. This means keeping the required control voltage to the control system at all times. Avoiding this practice must be discussed with GML’s Warranty Department.

Electrical system must provide quality power withing +/- 3% of nominal voltage and must have surge protection for each sports lighting pole.

WARRANTY**25-YEAR MANUFACTURER WARRANTY****TERMS & CONDITIONS****(2 of 2)**

6. Service Limitations Not Covered by this Contract: Maintenance, repair or replacement necessitated by loss or damage resulting from any external causes such as, but not limited to, theft, environmental conditions, negligence, misuse, abuse, improper electrical/power supply, unauthorized repairs by third parties, attachments, damage to cabinetry, equipment modifications, vandalism, animal or insect infestation, physical damage to Warranted Product(s) parts or components, failure of existing structures, supporting electrical systems or any non-GML equipment, or acts of nature (including, but not limited to: earthquake, flood, tornadoes, typhoons, hurricanes or lightning).

7. Contract Limitations:

a. Exclusions from coverage: in no event will GML be liable for any special, indirect, incidental or resulting damages which include, but are not limited to, any delay in rendering service or loss of use during the repair period of the Warranted Product(s) or while otherwise awaiting parts.

b. Limitation of liability: to the extent permitted by applicable law, the liability of GML, if any, for any allegedly defective Warranted Product(s) or components shall be limited to repair or replacement of the Warranted Product(s) or components at GML's option. This contract is your sole express warranty with respect to the Warranted Product(s). All implied warranties with respect to the Warranted Product(s) including, but not limited to, implied warranties of merchantability and fitness for a particular purpose, are hereby expressly excluded.

c. For the purposes of and by your acceptance of this Contract you acknowledge and agree that if a surety bond ("Bond") is provided the warranty and/or maintenance guarantee provided for in this Contract and any corresponding liability on behalf of the issuing surety under the Bond is limited to the first twelve (12) months of said warranty and/or maintenance guarantee coverage period. Any warranty and/or guarantee coverage period in excess of said initial 12-month period does not fall within the scope of the Bond and shall be the sole responsibility of GML.

d. GML requires reasonable access for a crane or man lift equipment to service the lighting system. GML will not be responsible for damage from operating the vehicle on the property when the equipment is operated in the proper manner over the designated access route.

e. Obsolescence or Environmental Restrictions: If during any maintenance or other work performed under this Warranty, any of the parts of the Warranted Product(s) are found to be either obsolete, no longer available, or prohibited by any state or federal agency, GML shall replace said parts with comparable parts and materials with equal operating characteristics solely at GML discretion. The cost of replacement of any obsolete cellular related technology shall be borne by you. Prior to completing any such work, GML shall notify you of the cost (if any) you will incur in the replacement of such parts under this section.

8. Transfer and Assignment: Except to owners, you shall not have the right to assign or otherwise transfer your rights and obligations under this Contract except with the prior written consent of GML; however, a successor in interest by merger, operation of law, assignment or purchase or otherwise of your entire business shall acquire all of your interests under this Contract.

9. Governing Law: Unless otherwise governed by applicable state law, the Contract shall be interpreted and enforced according to the laws of the State of Louisiana.

Subrogation: In the event GML repairs or replaces any Warranted Product(s), parts or components due to any defect for which the manufacturer or its agents or suppliers may be legally responsible, you agree to assign your rights of recovery to GML. You will be reimbursed for any reasonable costs and expenses you may incur in connection with the assignment of your rights. You will be made whole before GML retains any amounts it may recover.

PROJECT NAME: _____ FIXTURE TYPE: _____

SUBSTANTIAL COMPLETION DATE: _____ TOTAL # OF FIXTURES: _____

FIELD PERFORMANCE GUARANTEE

The proposed *Techline Sports Lighting* system outlined in the attached information will provide initial foot candle level required per specification (25 Years), for the *Prout School* sports lighting project.

25 YEAR LIFE CYCLE COST

64 Luminaires X .65 KW Demand per Luminaire X 0.07 KWh X 350 Annual Usage Hours
X 25 Years = \$25,480.00

AASHTO WIND RATING

Techline Sports Lighting insure that all luminaires, visors and cross-arm assemblies are rated at 150-mph (AASHTO) and all luminaires will maintain alignment.

Signed: 
Rodney M. Hawthorne, President

<u>LED Installation</u>	<u>Type Field</u>	<u>City</u>	<u>State/Country</u>
Abilene Chrisitan University	Football	Abilene	Texas
Addison High School	Football	Addison	Michigan
Alvin ISD	Football	Alvin	Texas
Amador Valley High School	Football	Pleasanton	California
Anguilla Football Association	Football	The Valley	Anguilla
Aqua Golf	Driving Range	Denver	Colorado
Ashland High School	Football	Ashland	Oregon
Atlanta Falcons	Football	Atlanta	Georgia
Banquete High School	Football	Robstown	Texas
Bay Village City Schools	Football	Bay Village	Ohio
Beale Air Force Base	AFB	Beale AFB	California
Belleville West High School	Tennis	Belleville	Illinois
Billy Bowlegs Park	Football, Soccer, Basketball	Ft. Myers	Florida
Birmingham Community Charter School	Football	Van Nuys	California
Bishop Kelley Stadium	Football	Tulsa	Oklahoma
Brentwood School	Football, Tennis, Pool	Los Angeles	California
Brentwood School	Softball	Los Angeles	California
Brewster Field	Soccer, Tennis	Belleair	Florida
Brookville Park	Tennis	Bourough of Queens	New York
Brunswick High School	Softball	Brunswick	Georgia
Buhler High School	Baseball	Buhler	Kansas
Cabot High School	Football	Cabot	Arkansas
Cal State Monterey Bay	Baseball, Softball, Soccer	Monterey Bay	California
Camp Pendleton	Pool	Oceanside	California
Campus High School	Tennis	Haysville	Kansas
Capitol Hill High School	Gym	Oklahoma City	Oklahoma
Castle Hill Park	Baseball	New York	New York
Castleberry High School	Soccer	Ft. Worth	Texas
Central Broward Regional Stadium	Cricket	Lauderhill	Florida
Central Catholic High School	Football	San Antonio	Texas
Chaffey High School	Baseball	Chino	California
Charter Oak	Fixtures	Covina	California
Citrus College	Football	Glendora	California
City of Seguin	Fixtures	Seguin	Texas
Clovis High School	Football	Freson	California
Coalinga Chestnut Park	Baseball	Huron	California
Colonel Young Park	Park	New York	New York
CSULB Walters Pyramid	Basketball	Long Beach	California
Daylis Stadium - Wendy's Field	Football	Billings	Montana
Del Mar Golf	Golf	Del Mar	California
Delsea Regional High School	Football	Franklinville	New Jersey
Detroit Monroe Coal Plant	Plant Facility	Belleville	Michigan
Devon Aire Park	Basketball	Miami	Florida
De Witt Clinton Park	Park	New York	New York
Diamond Bar High School	Pool	Diamond Bar	California
Dickson High School	Football	Dickson	Oklahoma
Dimmitt High School	Football	Dimmitt	Texas
Eastern Michigan University	Football	Ypsilanti	Michigan
Ecorse High School	Football	Ecorse	Michigan
Ernest Debs Park	Soccer	Bell	California
Everett Field Park	Skate Park	Newark	Ohio
Fabens ISD	Baseball, Football, Softball	Fabens	Texas
Faith Academy	Football	Marble Falls	Texas
Foothill High School	Football	Pleasanton	California
Fort Bliss Stout Fitness Track	Football	Fort Bliss	Texas
Franklin & Marshall College	Football	Lancaster	Pennsylvania

Fullerton Community College	Pool	Fullerton	California
George Mason University	Tennis	Fairfax	Virginia
Gilpin County Schools	Football	Blackhawk	Colorado
Glynn County Stadium	Football	Brunswick	Georgia
Groom ISD	Football, Track	Groom	Texas
Habersham High School	Football	Habersham	Georgia
Hancock ANG Fitness Track	Track	Syracuse	New York
Hearne High School	Football	Hearne	Texas
Heritage High School	Football	New Haven	Indiana
Heritage High School	Football	Vancouver	Washington
Hillsboro Stadium	Football, Softball, Soccer	Hillsboro	Oregon
Hobart and William Smith Colleges	Tennis	Geneva	New York
Hueneme High School	Football	Oxnard	California
Hutchinson High School	Football, Soccer	Hutchinson	Kansas
Icahn Stadium	Soccer / Multi	New York	New York
Infinity Park	Rugby Practice Field	Glendale	Colorado
Iowa Park High School	Baseball, Softball	Iowa Park	Texas
Iowa Tribe of Oklahoma	Campgrounds	Perkins	Oklahoma
Islip Marina Ballfields	Baseball	East Islip	New York
Jewish Life Center	Soccer	Palo Alto	California
John F. Kennedy Catholic High School	Football, Soccer	Sommers	New York
John Paul II Catholic HS	Football, Baseball	Greenville	North Carolina
Johnny Stevens	Fixtures Only	Wichita	Kansas
Jourdanton ISD	Football	Jourdanton	Texas
Junipero Serra High School	Football	Gardena	California
Keith Field	Baseball	Sagamore	Massachusetts
Kinkaid School	Football, Baseball	Houston	Texas
LA City College	Football, Soccer, Track, Softball	Los Angeles	California
Ladue Horton Watkins High School	Football	St. Louis	Missouri
Laguna Beach High School	Football	Escondido	California
Lancaster Bible College	Multi Sport Complex	Lancaster	Pennsylvania
LaSalle High School	Football	Cincinnati	Ohio
Lawrence Tech University	Football, Soccer, Lacrosse	Southfield	Michigan
Linden Park	Park	New York	New York
Little Rock AFB	AFB	Jacksonville	Arkansas
Logan Elm High School	Football, Soccer, Track	Circleville	Ohio
Marshall ISD	Baseball	Marshall	Texas
Martinsville Speedway	Race Track	Ridgeway	Virginia
McCarren Park	Baseball, Soccer	Brooklyn	New York
McFarland Park	Baseball	McFarland	California
McKenzie Stadium	Football	Vancouver	Washington
McQueen High School	Football	Reno	Nevada
Medina High School	Football	Medina	Texas
Memorial Park	Baseball, Softball	Rockport	Texas
Miami Dolphins Hard Rock Stadium	Football	Miami	Florida
Miami Hard Rock Tennis	Tennis	Miami	Florida
Middle Creek Ranch	Tennis	Blanco	Texas
MLB Urban Youth Academy	Baseball	Dallas	Texas
Monarch High School	Tennis	Louisville	Colorado
Moscone Playground	Playground	San Francisco	California
Northern Mariana Saipan Island	Soccer	Northern Mariana Island	Saipan
Norwood Ball Field	Field	Norwood	Pennsylvania
Olathe Soccer Complex	Soccer	Olathe	Kansas
Osceola High School	Football	Osceola	Arkansas
Owasso Public Schools	Football, Track, Baseball, Softball	Owasso	Oklahoma
Palisades Charter High School	Football	Pacific Palisades	California
Palm Beach Gardens	Soccer	Palm Beach Gardens	Florida
Pensacola Christian College	Baseball, Soccer	Pensacola	Florida

Piedmont High School	Football	Piedmont	California
Piqua High School	Football, Track	Piqua	Ohio
Pittsburg High School	Football	Coppell	Texas
Pond Creek Hunter High School	Football	Pond Creek	Oklahoma
Port Aransas Community Park	Baseball, Softball	Port Aransas	Texas
Purdue University	Football	West Lafayette	Indiana
Richmond International Raceway	Race Track	Richmond	Virginia
Rockport Memorial Park	Baseball, Softball	Rockport	Texas
San Jose State University	Golf Complex	San Jose	California
San Marcos Little League	Baseball	San Marcos	Texas
San Ysidro Port of Entry	Area	San Ysidro	California
Santa Fe High School	Football	Santa Fe	New Mexico
Santa Fe Trail USD	Football	Carbondale	Kansas
Savannah National Guard	Military Airport	Savannah	Georgia
Scrap Yard Sports Complex	Softball	Conroe	Texas
Sebring International Raceway	Race Track	Sebring	Florida
South Albany High School	Football	Albany	Oregon
South Kitsap High School	Football	South Kitsap	Washington
Southeast High School	Football	Bradenton	Florida
Spanish Springs High School	Football	Reno	Nevada
Sparks High School	Football	Reno	Nevada
Spotsylvania High School	Field Hockey, Football	Spotsylvania	Virginia
Spring Hill High School	Baseball, Softball	Spring Hill	Kansas
Springfield High School	Football	Erdenheim	Pennsylvania
St. Joseph By the Sea	Baseball, Softball	Staten Island	New York
St. Margaret High School	Football	San Juan Capistrano	California
St. Mary's Central High School	Football	Bismark	North Dakota
Stigler Sports Complex	Baseball, Soccer	Stigler	Oklahoma
Texas A&M University, Commerce	Tennis	Commerce	Texas
Texas City Shooting Range	Shooting Range	Texas City	Texas
Trinity Prep High School	Football	Winter Park	Florida
Tulia High School	Football, Baseball, Softball	Tulia	Texas
Tumwater Driving Range	Driving Range	Tumwater	Washington
Turner High School	Baseball	Kansas City	Kansas
Uintah High School	Baseball, Softball, Football	Vernal	Utah
Union High School	Football	Vancouver	Washington
University of North Texas	Tennis, Arena	Denton	Texas
Urbana University	Soccer	Urbana	Ohio
Valero Tank Yard	Yard	Beaumont	Texas
Valley View ISD	Softball	Valley View	Texas
Vernon-Verona-Sherill High School	Football	Verona	New York
Vicksburg Sports Complex	Multi Sport Complex	Vicksburg	Mississippi
Wamego USD 320	Football	Wamego	Kansas
Washoe County Schools	Football	Reno	Nevada
Weatherford High School	Baseball	Weatherford	Oklahoma
West Albany High School	Football	Albany	Oregon
WESCO Beaumont	Tank Yard	Beaumont	Texas
White Oak Middle School	Football	New Caney	Texas
Woodland Springs Middle School	Football	Spring Hill	Kansas
Workman Junior High School	Football	Arlington	Texas

MAJOR SPORTING EVENTS

2015 SUPER BOWL



2018 SUPER BOWL



2019 SUPER BOWL



2020 SUPER BOWL



2016 NCAA NATIONAL FOOTBALL CHAMPIONSHIP



2018 NCAA NATIONAL FOOTBALL CHAMPIONSHIP



2021 NCAA NATIONAL FOOTBALL CHAMPIONSHIP



2019 NCAA FINAL FOUR



2020 NCAA FINAL FOUR



CHICK-FIL-A PEACH BOWL



2019 TRIPLE-A NATIONAL CHAMPIONSHIP



MIAMI OPEN TENNIS TOURNAMENT



MARTINSVILLE SPEEDWAY



MLS CUP



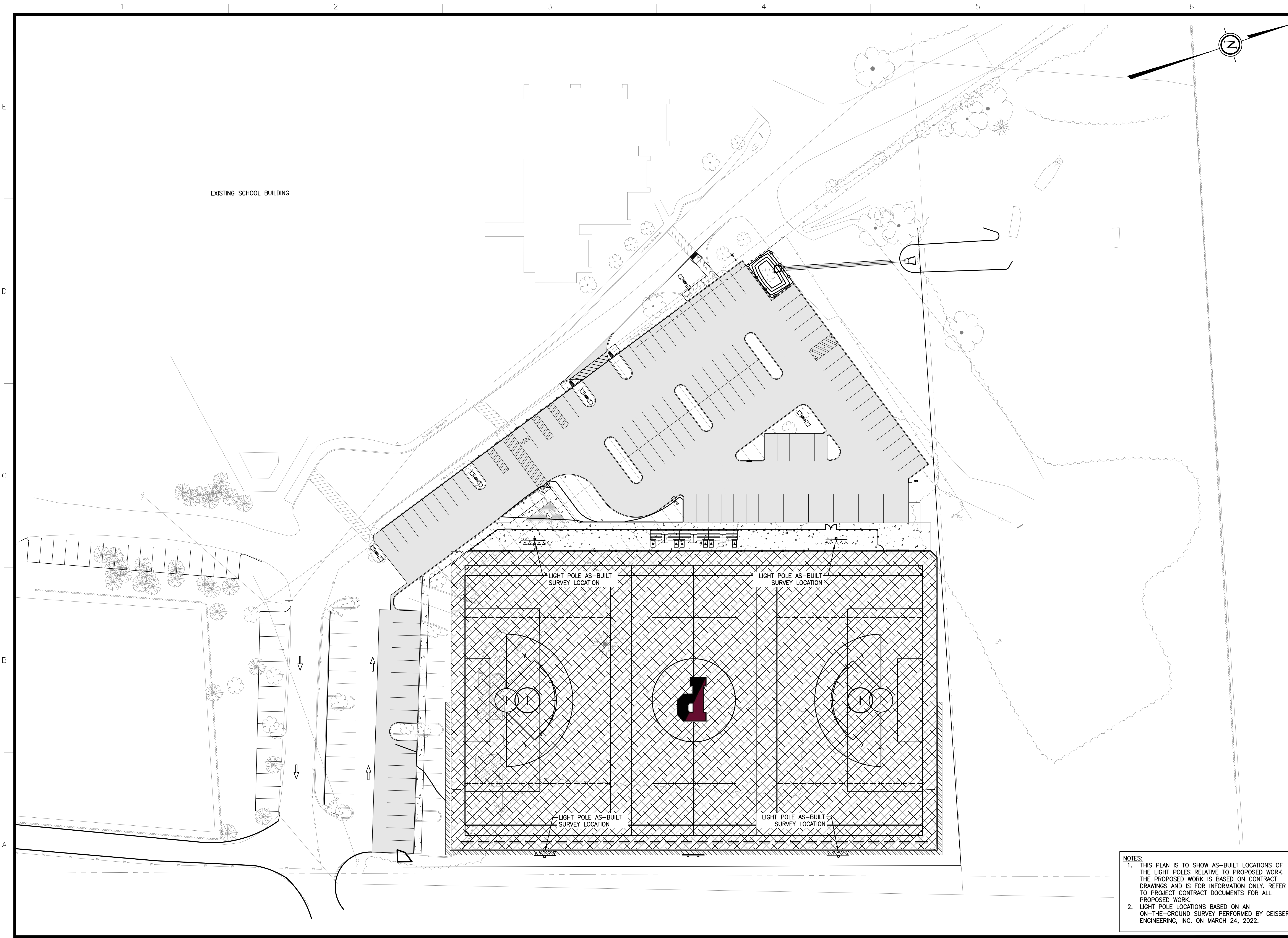

Gale Associates, Inc.
 Engineers and Planners
 163 LIBBEY PARKWAY | WEYMOUTH, MA 02189
 P 781.335.6485 F 781.335.6467
 www.gainc.com
 Boston Baltimore Orlando Connecticut

This drawing and the design and construction features disclosed are proprietary to Gale Associates, Inc. and shall not be altered or reused in whole or part without the express written permission of Gale Associates, Inc. Copyright©2019

AS-BUILT

PROJECT/APPLICANT
**THE PROUT SCHOOL
 ATHLETIC CAMPUS RENOVATIONS
 4640 TOWER HILL ROAD
 WAKEFIELD, RHODE ISLAND**

OWNER
**ROMAN CATHOLIC BISHOP OF PROVIDENCE
 1 CATHEDRAL SQUARE
 PROVIDENCE, RHODE ISLAND**

REVISIONS		
NO.	DATE	DESCRIPTION

CADD FILE 715792_LP-AS_BUILT
 DESIGNED BY
 DRAWN BY
 CHECKED BY
 DATE 3/25/2022
 DRAWING SCALE 1"=30'

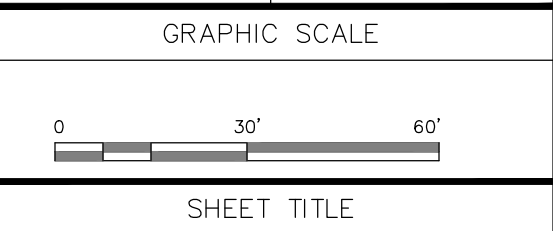

SHEET TITLE
**LIGHT POLE
 AS-BUILT
 LOCATION PLAN**

NOTES:
 1. THIS PLAN IS TO SHOW AS-BUILT LOCATIONS OF THE LIGHT POLES RELATIVE TO PROPOSED WORK. THE PROPOSED WORK IS BASED ON CONTRACT DRAWINGS AND IS FOR INFORMATION ONLY. REFER TO PROJECT CONTRACT DOCUMENTS FOR ALL PROPOSED WORK.
 2. LIGHT POLE LOCATIONS BASED ON AN ON-THE-GROUND SURVEY PERFORMED BY GEISSER ENGINEERING, INC. ON MARCH 24, 2022.

DRAWING NO.
LP
 PROJECT NO. 715792